



Engine Maintenance Manual (Principal Manual)

TEO-540-A1A Engine

October 2018

Part No. MM-TEO-540-A1A

TEO-540-A1A Engine Maintenance Manual

Lycoming Part Number: MM-TEO-540-A1A

Contact Us:

Mailing Address:

Lycoming Engines
652 Oliver Street
Williamsport, PA 17701 USA

Phone:

Factory

U.S. and Canada Toll Free:

+1 (800) 258-3279

Direct:

+1 (570) 323-6181

Technical Support Hotline

- +1 (877) 839-7878 (Toll Free)
- +1 (570) 327-7222
- Email Technicalsupport@lycoming.com

Lycoming's regular business hours are Monday through Friday from 8:00AM through 5:00PM Eastern Time (-5 GMT).

Visit us Online: www.lycoming.com

NOTE:

Lycoming recommends that owners of this manual sign up for email notification on the Technical Publications page of our website <https://www.lycoming.com/contact/knowledge-base/publications>. By submitting your email address, you will receive notification whenever Lycoming publishes a new or revised technical publication, including any revisions to this Engine Maintenance Manual.



RECORD OF REVISIONS

Revision	Revision Date	Revised By	Revision Description
Original			Original Release of Maintenance Manual - Part No. MM-TEO-540-A1A

This page intentionally left blank.

SERVICE DOCUMENT LIST

NOTICE: The following is a list of service documents referenced in or incorporated into the information in this manual. Always refer to the latest revision of any service document (including any supplements) for changes or additional information. Supplements to a service document contain information relevant to the service document but not yet added to the service document.

The latest revision of all service documents in this list can be downloaded from our website <https://www.lycoming.com/contact/knowledge-base/publications>.

To narrow the search parameters and limit the number of returns, enter only the numerical portion of the service document number in the **Search** box on the website.

Number	Incorporation Date	Subject
S.B. 201	10/18	Inspection of Crankshaft Flange
S.B. 225	10/18	Replacement of Valve Rocker Thrust Washers
S.B. 240	10/18	Mandatory Parts Replacement at Overhaul and During Repair or Maintenance
S.B. 357	10/18	Engine Inspection After an Engine Has Been Soaked or Immersed
S.B. 369	10/18	Engine Inspection after Overspeed
S. B. 388	10/18	Procedure to Determine Exhaust Valve and Guide Condition
S.B. 398	10/18	Recommended Corrective Action for Use of Incorrect Fuel
S.B. 399	10/18	Action to Take If Loss of Oil Pressure
S.B. 401	10/18	Recommendations for Aircraft Struck by Lightning
S.B. 475	10/18	Crankshaft Gear Modification and Assembly Procedures
S.B. 480	10/18	Oil, Oil Filter, Oil Pressure Screen, and Oil Suction Screen Servicing
S.B. 505	10/18	Inspection of Crankshaft I.D. for Corrosion
S.B. 530	10/18	Connecting Rod Bushing Inspection
S.B. 533	10/18	Recommended Action for Sudden Engine Stoppage, Propeller/Rotor Strike or Loss of Propeller/Rotor Blade or Tip
S.B. 592	10/18	Engine Inspection after Overboost
S.I. 1009	10/18	Time Between Overhaul (TBO) Schedules
S.I. 1011	10/18	Tappets and Lifters
S.I. 1012	10/18	Counterweights and Rollers on Engine Models
S.I. 1014	10/18	Lubricating Oil Recommendations

SERVICE DOCUMENT LIST (CONT.)

Number	Incorporation Date	Subject
S.I. 1043	10/18	Spark Plug Heli-Coil® Insert Replacement
S.I. 1047	10/18	Inspection and Reconditioning Procedures for Nitride Hardened Steel Cylinders
S.I. 1059	10/18	Pre-Lubrication of Parts Before Assembly
S.I. 1070	10/18	Specified Fuels for Spark-Ignited Gasoline Aircraft Engine Models
S.I. 1080	10/18	Maintenance Items for Special Attention
S.I. 1098	10/18	Propeller Flange Bushing Location
S.I. 1129	10/18	Methods of Checking DC Alternator and Generator Belt Tension
S.I. 1142	10/18	Replacement of Crankshaft Counterweight Bushings
S.I. 1172	10/18	Adjustable Oil Pressure Relief Valve Installation and Valve Seat Repair or Replacement
S.I. 1191	10/18	Cylinder Compression
S.I. 1204	10/18	Exhaust Flange Gaskets
S.I. 1238	10/18	Assembly and Torque Procedures for V-Band Couplings
S.I. 1241	10/18	Pre-oil the Engine Prior to Initial Start
S.I. 1267	10/18	Piston Pin Plug Usage
S.I. 1285	10/18	Non-Destructive Testing of Lycoming Engine Parts
S.I. 1301	10/18	Identification of Primer and Fuel Injector Lines
S.I. 1304	10/18	Engine Nameplate Replacement
S.I. 1316	10/18	Valve Seat Refacing on Oil Cooler Bypass Valves
S.I. 1324	10/18	Crankshaft Oil Seals
S.I. 1340	10/18	Piston Pin Identification
S.I. 1409	10/18	Lycoming Engines P/N LW-16702 Oil Additives
S.I. 1425	10/18	Suggested Maintenance Procedures to Reduce the Possibility of Valve Sticking
S.I. 1427	10/18	Field Run-In and Break-In
S.I. 1458	10/18	Connecting Rod Bolts (Identification and Installation)
S.I. 1462	10/18	Propeller Oil Control Leak Test Procedure
S.I. 1485	10/18	Exhaust Valve and Guide Identification Procedure
S.I. 1492	10/18	Piston Pin Plug Wear Inspection

SERVICE DOCUMENT LIST (CONT.)

Number	Incorporation Date	Subject
S.I. 1511	10/18	Inspection of “PID” Stamped Crankshafts
S.I. 1514	10/18	Roller Tappets Part Information Update
S.I. 1530	10/18	Engine Inspection in Particulate-Laden Environments
S.I. 1535	10/18	Counterweight and Roller Removal, Inspection, and Installation
S.I. 1562	10/18	Turbocharged Exhaust System Installation
S.I. 1566	10/18	Lycoming Engines Approves the Use of Safety Cable
S.I. 1573	10/18	Lycoming TEO-540 Engine Series Engine Control Unit (ECU) Assembly Cross-References
L114	10/18	Reciprocating Engine and Accessory Maintenance Publications
L171	10/18	General Aspects of Spectrometric Oil Analysis
L180	10/18	Engine Preservation Guidelines for Active and Stored Aircraft
L192	10/18	Spark Plug Fouling
L193	10/18	Engine Firing Order
L197	10/18	Recommendations to Avoid Valve Sticking
L221	10/18	Warranty Repair of Precision Airmotive Corporation Fuel Control Products
L247	10/18	Shelf Life Requirements
L253	10/18	Warranty Repair of AVStar Fuel Systems, Inc. Fuel Control Products
L270	10/18	Extended Maintenance Intervals for Spark-Ignited Engines Operated on Unleaded Fuels

This page intentionally left blank.

TABLE OF CONTENTS

<u>Subject</u>	<u>Page</u>
<u>Title Page</u>	
<u>Record of Revisions</u>	i
<u>Service Document List</u>	iii
<u>Table of Contents</u>	vii
<u>Abbreviations and Acronyms</u>	xvii
<u>Introduction</u>	xxi
<u>Airworthiness Limitations</u>	xxvii
<u>Required Maintenance</u>	05-00
— <u>Required Maintenance</u>	1
— <u>General</u>	1
— <u>List of Tools for Service and Maintenance</u>	1
— <u>Table 1 - Tools for Service and Maintenance</u>	1
— <u>Time Between Overhaul (TBO)</u>	3
— <u>Safety Precautions - Before Engine Maintenance</u>	3
— <u>Maintenance Practices</u>	3
— <u>General Engine Inspection Criteria</u>	5
— <u>Requirements for Engine Maintenance</u>	5
— <u>Approved Parts</u>	5
<u>Time Limits / Inspections</u>	05-10
— <u>Engine Inspection Schedule for TEO-540-A1A Engines</u>	7
<u>Required Engine Inspections for TEO-540-A1A Engines</u>	05-20
— <u>Engine Inspections</u>	9
— <u>Visual Inspection for TEO-540-A1A Engines</u>	9
— <u>Operational Leak Checklist for TEO-540-A1A Engines</u>	16
— <u>10-Hour Initial Engine Inspection for TEO-540-A1A Engines</u>	17
— <u>25-Hour Engine Inspection for TEO-540-A1A Engines</u>	19
— <u>50-Hour Engine Inspection for TEO-540-A1A Engines</u>	21
— <u>100-Hour or Annual Engine Inspection for TEO-540-A1A Engines</u>	24
— <u>250-Hour Engine Inspection for TEO-540-A1A Engines</u>	29
— <u>400-Hour Engine Inspection for TEO-540-A1A Engines</u>	30
— <u>1000-Hour Engine Inspection for TEO-540-A1A Engines</u>	32

<u>Subject</u>	<u>Page</u>
<u>Cleaning</u>	05-30
— <u>Cleaning Guidelines</u>	35
— <u>Table 1 - Cleaning Guidelines for Engine Components</u>	36
— <u>Crankshaft Cleaning</u>	38
— <u>Crankshaft Counterbore Cleaning</u>	38
— <u>Crankshaft Trigger Gear Assembly Cleaning</u>	39
— <u>Tappet Cleaning</u>	40
— <u>Crankcase Cleaning</u>	40
— <u>Grit-Blasting</u>	40
— <u>Soft Carbon Removal</u>	41
— <u>Hard Carbon Removal</u>	42
— <u>Cylinder Cleaning</u>	42
— <u>Piston Cleaning</u>	43
— <u>Steel, Aluminum, or Magnesium Parts Cleaning</u>	43
— <u>Spark Plug Cleaning</u>	44
— <u>Lead Deposit Removal</u>	44
— <u>Volcanic Ash Removal</u>	45
— <u>Cleaning Guidelines for a Soaked Engine</u>	45
— <u>Cleaning Methods for Non-Destructive Testing</u>	46
<u>Unscheduled Corrective Maintenance</u>	05-50
— <u>Unscheduled corrective maintenance is necessary when any of the following conditions occur:</u>	47
— <u>Lightning Strike - After a lightning strike</u>	47
— <u>Engine Overspeed</u>	48
— <u>Table 1 - Overspeed Values for TEO-540-A1A Engines</u>	48
— <u>Engine Overboost</u>	50
— <u>Incorrect Fuel or Fuel Contamination</u>	50
— <u>Soaked Engine</u>	51
— <u>Engine on Fire or Near a Fire</u>	52
— <u>Hydraulic Lock</u>	53
— <u>Volcanic Ash/Particulate Contamination</u>	53
— <u>Table 2 - Action to Take in Volcanic Ash Conditions</u>	54
— <u>Valve Sticking</u>	55
— <u>Oil Starvation/Sudden Loss of Oil Pressure</u>	55
— <u>Metal Contamination of the Lubrication System</u>	56
— <u>NTO & TLO Illumination on the Control Panel</u>	56
— <u>Propeller Strike, Sudden Engine Stoppage or Loss of a Propeller Blade Tip</u>	57
— <u>Non-Destructive Testing (Magnetic Particle Inspection and Fluorescent Penetrant Inspection.)</u>	64

<u>Subject</u>	<u>Page</u>
<u>Servicing - Replenishing</u>	12-10
— <u>Refueling</u>	65
— <u>Oil Level Check</u>	65
— <u>Oil Consumption</u>	66
— <u>Oil Type and Viscosity</u>	66
— <u>Add Oil to the Engine</u>	66
— <u>Oil Leak Check</u>	67
— <u>Oil Servicing Schedule</u>	67
— <u>Table 1 - Oil Servicing Schedule</u>	67
— <u>Oil Change Procedure</u>	68
— <u>Engine Pre-Oil Procedure</u>	69
— <u>Oil Suction Screen Removal/Inspection/Cleaning/Installation</u>	71
— <u>Oil Filter Replacement</u>	72
— <u>Oil Filter Inspection</u>	73
— <u>Identification of Metallic Solids After Oil Servicing</u>	73
— <u>Visual Inspection of the Oil Filter Element and Oil Suction Screen</u>	73
— <u>Table 2 - Guidelines for Identification of Metal Particulates and Chips & Corrective Action</u>	75
— <u>Table 3 - Guidelines for Particle Quantity and Size on Oil Filter or Oil Suction Screen</u>	77
— <u>Recommended Corrective Action Options</u>	79
— <u>Table 4 - Recommended Corrective Action Options</u>	79
— <u>Oil Contamination Check</u>	80
<u>Fault Isolation</u>	12-30
— <u>Recommended Approach to Fault Isolation</u>	81
— <u>Table 1 - Fault Isolation Guide</u>	81
<u>Engine Removal and Return to Service</u>	72-00
— <u>Engine Removal Prerequisites</u>	101
— <u>Engine Removal Procedure</u>	101
— <u>Engine Installation Preparation Requirements</u>	103
— <u>Table 1 - Materials and Procedures to Prepare a Serviced Engine for Installation</u>	104
— <u>Operational Ground Check</u>	104
— <u>Engine Mount Inspection</u>	105
— <u>Return to Service Procedure</u>	105

<u>Subject</u>	<u>Page</u>
<u>Engine Disassembly</u>	72-05
— <u>Engine Disassembly Procedure</u>	107
— <u>Table 1 – Sequence of Engine Disassembly Procedure</u>	107
<u>Engine Assembly</u>	72-10
— <u>Corrosion Prevention</u>	113
— <u>Painting the Engine and Engine Components</u>	113
— <u>Table 1 – Paint Stripping and Painting Guidelines for Components</u>	113
— <u>Limits and Clearances</u>	115
— <u>Inspections</u>	115
— <u>Engine Assembly Procedure</u>	116
— <u>Table 2 – Sequence of Engine Assembly Procedure</u>	116
— <u>Engine Assembly Checklist</u>	122
<u>Propeller Flange Bushing Replacement</u>	72-15
— <u>Propeller Flange Bushing Removal</u>	127
— <u>Propeller Flange Bushing Installation</u>	127
<u>Crankcase Maintenance</u>	72-20
— <u>Exterior Crankcase Inspection</u>	129
— <u>Connecting Rod Removal</u>	130
— <u>Crankcase Disassembly</u>	130
— <u>Crankshaft Disassembly</u>	136
— <u>Interior Crankcase Inspection</u>	139
— <u>Crankshaft Inspection</u>	142
— <u>Crankshaft Bearing Surface Inspection</u>	151
— <u>Table 1 - Crankshaft Undersize Codes</u>	151
— <u>Bearing Shell Surface Inspection</u>	152
— <u>Gear Inspection</u>	152
— <u>Screwed Fitting Inspection</u>	152
— <u>Camshaft Disassembly and Inspection</u>	153
— <u>Connecting Rod Inspection</u>	154
— <u>Connecting Rod Bushing Replacement</u>	158
— <u>Connecting Rod Parallelism / Squareness Check</u>	159

<u>Subject</u>	<u>Page</u>
<u>Crankcase Maintenance (Cont.)</u>	72-20
— <u>Tappet Inspection</u>	160
— <u>Crankshaft Assembly</u>	160
— <u>Piston Cooling Nozzle Installation (if removed)</u>	170
— <u>Oil Plug Installation (if removed)</u>	170
— <u>Tappet Assembly Installation</u>	171
— <u>Crankshaft Bearing and O-Ring Installation</u>	172
— <u>Propeller Governor Drive Installation</u>	172
— <u>Table 2 - Thrust Washer Thickness</u>	172
— <u>Camshaft Assembly and Installation</u>	175
— <u>Crankshaft Installation</u>	177
— <u>Table 3 - Slinger Clearance at Point A</u>	178
— <u>Table 4 - End Play Clearance at Point B</u>	178
— <u>Crankcase Assembly</u>	178
— <u>Table 5 - Crankcase Fastener Torque Values</u>	182
— <u>Crankshaft End Play Clearance Check</u>	183
— <u>Propeller Oil Control Leak Test</u>	184
— <u>Crankshaft Oil Seal Installation</u>	186
— <u>Crankshaft Trigger Gear Assembly and Crankshaft Idler Gear Installation</u>	189
— <u>Electronic Propeller Governor Removal</u>	194
— <u>Electronic Propeller Governor Installation</u>	194
— <u>Crankshaft-to-Camshaft Timing Check</u>	194
<u>Accessory Housing Maintenance</u>	72-25
— <u>Accessory Housing Removal</u>	197
— <u>Oil Pump Removal</u>	198
— <u>Oil Pump Installation</u>	198
— <u>Turbo Scavenge Pump Removal</u>	199
— <u>Turbo Scavenge Pump Installation</u>	199
— <u>Accessory Housing Installation</u>	200

<u>Subject</u>	<u>Page</u>
<u>Cylinder Maintenance</u>	72-30
— <u>General</u>	201
— <u>Table 1 - Regularly Scheduled Cylinder Inspections</u>	201
— <u>Visual Cylinder Inspection</u>	201
— <u>Cylinder Compression Check</u>	202
— <u>Table 2 - Summary of Cylinder Compression Check Results and Corrective Action</u>	206
— <u>Intercylinder Baffle Inspection</u>	207
— <u>Cylinder Borescope Inspection</u>	208
— <u>Table 3 - Borescope Inspection Steps, Results, and Corrective Action</u>	209
— <u>Exhaust Valve and Guide Inspection</u>	209
— <u>Cylinder Removal</u>	214
— <u>Piston Removal</u>	219
— <u>Cylinder Assembly Inspection</u>	220
— <u>Piston Inspection</u>	226
— <u>Piston Ring Replacement</u>	230
— <u>Piston Installation</u>	231
— <u>Intake Valve Replacement</u>	232
— <u>Exhaust Valve Replacement</u>	233
— <u>Cylinder Installation</u>	233
— <u>Corrective Action for Valve Sticking</u>	241
— <u>Intake and Exhaust Valve Guide Replacement</u>	243
— <u>Intake and Exhaust Valve Seat Replacement</u>	243
— <u>Barrel Glaze and Varnish Removal from Interior Cylinder Barrel</u>	243
— <u>Heli-Coil® Replacement</u>	244
<u>Turbocharger Maintenance</u>	72-40
— <u>General</u>	247
— <u>50-Hour Turbocharger Inspection</u>	247
— <u>100-Hour Turbocharger Inspection</u>	248
— <u>250-Hour Turbocharger Inspection</u>	249
— <u>Turbocharger Removal</u>	250
— <u>Turbocharger Installation</u>	251
— <u>Exhaust Bypass Valve Replacement</u>	254

<u>Subject</u>	<u>Page</u>
<u>Lubrication System Maintenance</u>	72-50
— <u>Oil Pressure Adjustment</u>	255
— <u>Oil System Inspection</u>	255
— <u>Oil Hose Inspection</u>	255
— <u>Oil Hose Replacement (General Instructions for Any Oil Hose)</u>	256
— <u>Oil Filler Extension and Oil Level Gage Assembly Removal</u>	256
— <u>Oil Filler Extension and Oil Level Gage Assembly Installation</u>	257
— <u>Oil Pressure Relief Valve Removal</u>	257
— <u>Oil Pressure Relief Valve Inspection</u>	257
— <u>Oil Pressure Relief Valve Installation</u>	258
— <u>Oil Cooler Bypass Valve Removal</u>	258
— <u>Oil Cooler Bypass Valve Cleaning</u>	258
— <u>Oil Cooler Bypass Valve Installation</u>	258
— <u>Oil Sump Removal</u>	259
— <u>Oil Sump Inspection</u>	260
— <u>Oil Sump Installation</u>	260
<u>Accessory Drives</u>	72-60
— <u>Accessory Drive Inspection</u>	263
— <u>Vacuum Pump Replacement (if installed)</u>	263
— <u>Vacuum Pump Driven Gear Replacement (if installed)</u>	263
<u>Electrical System Maintenance</u>	72-70
— <u>Wiring Inspection</u>	265
— <u>Alternator Belt Inspection</u>	266
— <u>Alternator Belt Tension Check/Adjustment</u>	266
— <u>Table 1 - Required Torque (Belt Tension)</u>	267
— <u>Power Box and PMA</u>	269
— <u>The Electrical System Includes Three Wiring Harnesses</u>	269
— <u>Wiring Harness Connectors</u>	270
— <u>Table 2 – Wiring Harness Connector Guidelines</u>	270
— <u>Sensor Replacement Procedures</u>	277
— <u>Table 3 - Sensor Replacement Procedures</u>	277

<u>Subject</u>	<u>Page</u>
<u>Electrical System Maintenance (Cont.)</u>	72-70
— Engine-to-Firewall Wiring Harness Removal	287
— Engine-to-Firewall Wiring Harness Installation	290
— Airframe Interface Wiring Harness Removal	291
— Airframe Interface Wiring Harness Installation	292
— ECU Removal	293
— ECU Installation	293
— Power Box Removal	294
— Power Box Installation	294
— Permanent Magnet Alternator (PMA) Replacement	294
— Starter Replacement	295
— Alternator and Bracket Removal	296
— Alternator and Bracket Installation	298
— Alternator Belt Replacement	299
— Starter Ring Gear Support Replacement	299
— Starter Ring Gear Replacement	300
<u>Induction System Maintenance</u>	72-80
— Induction System Inspection	303
— Intake Pipe Replacement	303
— Fuel Drain Valve Adapter Assembly Inspection	305
— Induction Housing Replacement	305
— Air Inlet Housing Replacement	306
<u>Engine Fuel and Control - Distribution</u>	73-10
— Fuel System Inspection	307
— Fuel Hose Inspection	309
— Table 1 - Corrective Action for Fuel Hoses	311
— Fuel Injector Leak Check	311
— Fuel System Inspection	312
— Fuel Hose Replacement	315
— Fuel Injector Rail Assembly Replacement	317
— Fuel Injector Replacement	319

<u>Subject</u>	<u>Page</u>
<u>Engine Fuel and Control - Distribution (Cont.)</u>	73-10
— Fuel Injector Adapter Replacement	320
— Fuel Pump Filter Replacement	321
— Fuel Pump Replacement	322
— Fuel Regulator Adapter Manifold Assembly Replacement	323
<u>Engine Fuel and Control - Controlling</u>	73-20
— (Electronic) Throttle Body Replacement	327
— Operational Test of Throttle Body	328
<u>Ignition System Maintenance</u>	74-20
— Ignition Lead Removal	329
— Table 1 - Ignition Leads	330
— Spark Plugs	331
— Spark Plug Removal	331
— Ignition Lead Inspection	331
— Spark Plug Inspection	332
— Table 2 - General Spark Plug Wear/Replacement Guidelines	332
— Spark Plug Fouling	333
— Spark Plug Port Seal Inspection	333
— Spark Plug Cleaning	334
— Spark Plug Gap Setting	334
— Spark Plug Rotation	334
— Table 3 - Spark Plug Rotation Scheme	334
— Spark Plug Installation	335
— Ignition Lead Installation	335
<u>Coil Assembly and Coil Box Maintenance</u>	74-30
— Coil Box Access	337
— Coil Assembly Replacement	338
— Coil Box Removal	339
— Coil Box Installation	340

<u>Subject</u>	<u>Page</u>
<u>Exhaust System Maintenance</u>	78-00
— <u>Heat Shield Removal</u>	341
— <u>50-Hour Exhaust System Inspection</u>	342
— <u>100-Hour Exhaust System Inspection</u>	342
— <u>250-Hour Exhaust System Inspection</u>	342
— <u>Heat Shield Installation</u>	345
— <u>Exhaust System Removal</u>	345
— <u>Exhaust System Installation</u>	346
— <u>Intercooler Replacement</u>	349
— <u>Turbocharger-to-Intercooler Pipe Replacement</u>	349
<u>Appendix A</u>	
— <u>Stud Replacement</u>	351
— <u>Air Bleed Nozzle Installation</u>	352
— <u>Fin Stabilizer Installation</u>	352
<u>Appendix B</u>	
— <u>Wiring Diagrams</u>	353
— <u>Table B-1 - Wiring Harness Leads and Connection Location</u>	353
— <u>Schematic T-11327-Y</u>	357
— <u>Communications Bus Data</u>	365
<u>Appendix C</u>	
— <u>Field Service Tool User Manual Abbreviations and Acronyms</u>	367
— <u>System Requirements</u>	369
— <u>Software Installation</u>	371
— <u>ECU to FST Connection</u>	379
— <u>Access the Field Service Tool</u>	381
— <u>Sending Data to Lycoming Technical Support</u>	389
— <u>Field Service Tool - Software Problems</u>	391
<u>Appendix D</u>	
— <u>Troubleshooting Guide Abbreviations and Acronyms</u>	393
— <u>Troubleshooting Guide</u>	396

ABBREVIATIONS AND ACRONYMS

A	
ADL	Data Logger
AMM	Airframe Manufacturer's Manual
ATA	Air Transportation Association
C	
C	Celsius
CAM	Camshaft Speed Sensor
CHT	Cylinder Head Temperature
CIP-P	Primary Compressor Inlet Pressure
CIP-S	Secondary Compressor Inlet Pressure
cm	Centimeter
CRANK	Crankshaft Speed Sensor
D	
DECK-P-P	Primary Induction Air Deck Temperature
DECK-P-S	Secondary Induction Air Deck Temperature
DECK-T	Induction Air Deck Temperature
DPS	Delta Pressure Sensor
E	
ECU	Engine Control Unit
EECS	Electronic Engine Control System
EGT	Exhaust Gas Temperature
F	
F	Fahrenheit
FAA	Federal Aviation Administration
FAR	Federal Aviation Regulation
FFL	Fault Found
FPI	Fluorescent Penetrant Inspection
FPP	Fuel Pump Pressure Sensor
FOD	Foreign Object Debris
FPI	Fluorescent Penetrant Inspection
FPP	Fuel Pump Pressure Sensor
FST	Field Service Tool
ft.-lb.	Foot Pound (torque)
FUEL-P	Fuel (Rail) Pressure Sensor
FUEL-T	Fuel Temperature Sensor

ABBREVIATIONS AND ACRONYMS (CONT.)

I	
ICA	Instructions for Continued Airworthiness
ID	Identification; Inside/Inner Diameter
in.-lb.	Inch Pound (torque)
in.	Inch, inches
In-Hg	Inches of Mercury
IOM	Engine Installation and Operation Manual
K	
KNOCK	Knock Sensor
kPa	Kilopascal
L	
l	Liter
Lb.	Pound
M	
MAP	Manifold Air Pressure
MAT-P	Primary Induction Air Manifold Temperature Sensor
MAT-S	Secondary Induction Air Manifold Temperature Sensor
MEK	Methyl-Ethyl-Ketone
mm	Millimeter
MPI	Magnetic Particle Inspection
MSB	Mandatory Service Bulletin
N	
NDT	Non-Destructive Testing
Nm	Newton Meters
NPT	National Pipe Thread
NTO	No Take-Off
O	
OD	Outside/Outer Diameter
OEM	Original Equipment Manufacturer
OIL-P	Oil Pressure Sensor
OIL-T	Oil Temperature Sensor
P	
PMA	Permanent Magnet Alternator or Parts Manufacturer Approval
P/N	Part Number
POH	Pilot's Operating Handbook
ppm	Parts per Million
psi	Pounds per square inch

ABBREVIATIONS AND ACRONYMS (CONT.)

R	
rpm	Revolutions per Minute
S	
SA	Special Advisory
SAE	Society of Automotive Engineers (oil viscosity)
SB	Service Bulletin
SI	Service Instruction
STC	Supplemental Type Certificate
T	
TBO	Time Between Overhaul
TDC	Top Dead Center
TIR	Total Indicator Reading
TIT	Turbine Inlet Temperature Sensor
TLO	Time-Limited Operation
TPS	Throttle Position Sensor

This page intentionally left blank.

INTRODUCTION

The Lycoming TEO-540-A1A Engine (Figure 1) is a direct-drive six-cylinder, horizontally opposed, turbocharged, electronically-controlled engine. It has electronic fuel injection, electronic ignition, electronic propeller governor control (an optional electronic propeller governor can be used), down exhaust, and induction air coolers. As standard equipment, this engine has automotive type starter, two alternators, and three AN type accessory drives (two standard and one high speed).

The engine has an Electronic Engine Control System (EECS) which is a microprocessor. The EECS continuously monitors and automatically adjusts operating conditions such as ignition timing, fuel injection timing, and fuel mixture. The EECS eliminates the need for magnetos and manual fuel/air mixture control. Refer to the "System Description" chapter in the *TEO-540 A1A Engine Installation and Operation Manual* for more details.

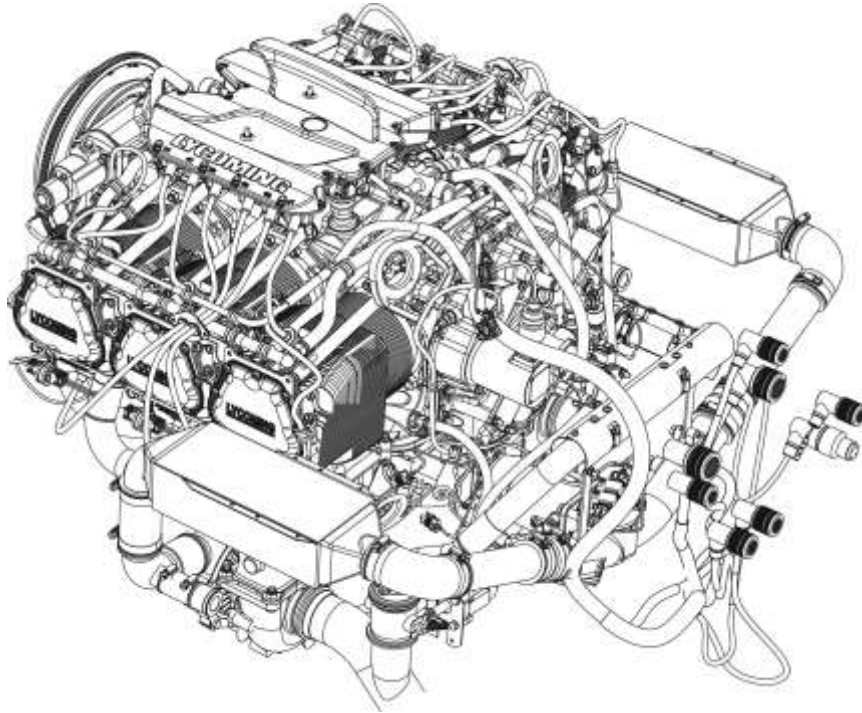


Figure 1
TEO-540-A1A

Engine Model Nomenclature

The table below identifies the basic nomenclature of the TEO-540 engine models. Hyphenated numbers and letters in the suffix (A1A) of the engine model number are configuration designations associated with the core engine.

Model Number	Meaning
T	Turbocharged
E	Electronic Engine Control System
O	Horizontally Opposed
540	Displacement in cubic inches

Engine Serial Number/Engine Data Plate

Every engine sent from the factory is identified by a unique serial number. The engine serial number is identified on the engine data plate (Figure 2). Do not remove the engine data plate.

If a data plate is ever lost or damaged, refer to the latest revision of Service Instruction No. SI-1304 for data plate replacement information.



Figure 2
Engine Data Plate

Cylinder Number Designations

- The propeller is at the front of the engine and the accessories are at the rear of the engine.
- In a top view of the engine, the left side cylinders are 2-4-6. Cylinder 2 is at the front of the engine. Refer to Figure 3.
- In a top view of the engine, the cylinders on the right are 1-3-5. Cylinder 1 is at the front of the engine. Refer to Figure 3.
- The firing order of the cylinders is 1-4-5-2-3-6

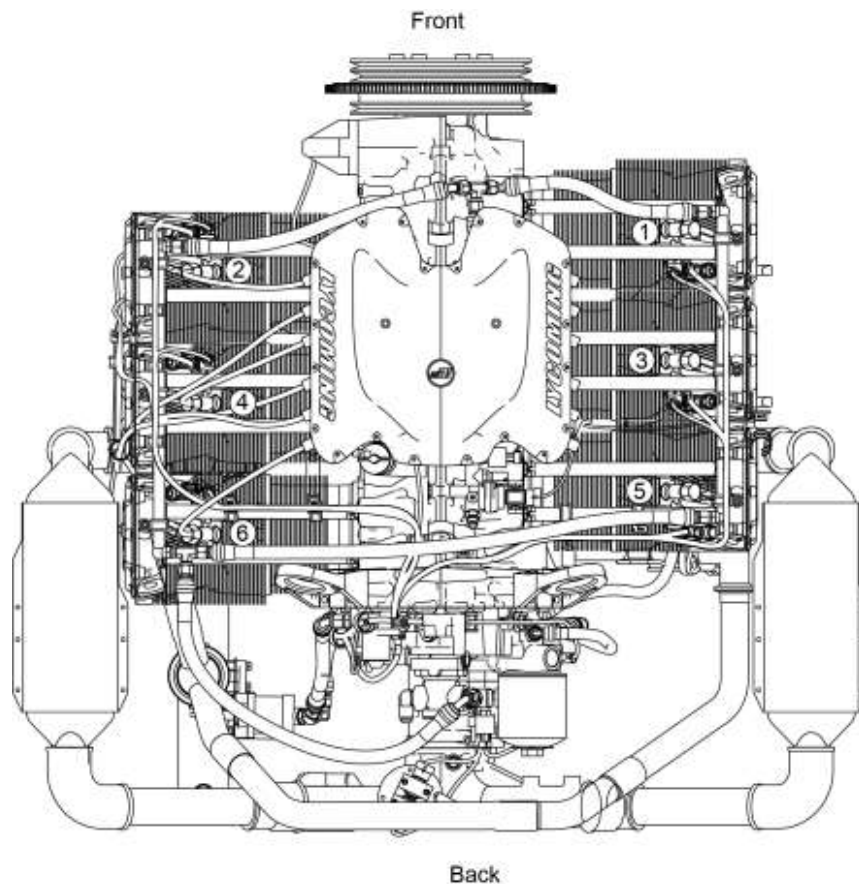


Figure 3
Top View of Engine – Cylinder Number Designations

Scope of this Manual

This manual supplies instructions (in compliance with Federal Aviation Regulation Part 14 CFR 33.4) for maintenance of the Lycoming TEO-540-A1A engine. These instructions include: required maintenance (service information) such as: oil changes, oil addition, oil filter replacement, routine time-interval inspections, routine service, spark plug replacement/inspection procedures, cylinder inspection, fuel system inspection, scheduled servicing procedures, airworthiness limitations, fault isolation guidelines and procedures for component replacement, engine disassembly, and engine assembly. Refer to the *TEO-540-A1A Illustrated Parts Catalog* to identify spare parts.


Instructions for Continued Airworthiness

This manual, the *TEO-540-A1A Engine Overhaul Manual*, the latest revision of the *Service Table of Limits - SSP-1776*, and service documents applicable to this engine model make up the complete set of Instructions for Continued Airworthiness (ICAs). The ICAs are prepared by Lycoming Engines.

Engine Certification

This manual adheres to guidelines set forth by the FAA for certified engines. All inspections, procedures, and guidelines in this manual must be followed to maintain continued airworthiness.

Compliance Requirements

 **WARNING** FOR CORRECT ENGINE MAINTENANCE, COMPLETE THE NECESSARY MAINTENANCE PROCEDURES IN THIS MANUAL AND APPLICABLE SERVICE DOCUMENTS. LYCOMING ENGINES' SERVICE DOCUMENTS WRITTEN AT A LATER DATE SUPERSEDE PROCEDURES IN THIS MANUAL UNLESS OTHERWISE SPECIFIED.


PROCEDURES IN THIS MANUAL MUST BE DONE BY QUALIFIED PERSONNEL WITH THE REQUISITE CERTIFICATIONS.

Before you do maintenance on the TEO-540-A1A engine, read this manual in its entirety. Obey all procedures and inspections in this manual.

NOTICE: Please read your warranty for a full statement of your rights, limitations and obligations that exist there under.

Refer to the *TEO-540-A1A Engine Installation and Operation Manual* for engine description, uncrating procedures, acceptance check, engine lift procedure, engine preservation and storage, depreservation, engine installation requirements, engine installation, engine start, operation, and stop procedures, engine initiation (break-in/flight test), fuels and oil to be used, and operating specifications.

Refer to the latest revision of the *Service Table of Limits - SSP-1776*, for dimensions, clearances, measurements, and torque values.

 **WARNING** OPERATE THIS ENGINE IN ACCORDANCE WITH SPECIFICATIONS IN APPENDIX A OF THE TEO-540-A1A ENGINE INSTALLATION AND OPERATION MANUAL. OPERATION OF THE ENGINE OUTSIDE OF THE SPECIFIED OPERATING LIMITS CAN CAUSE PERSONAL INJURY AND/OR DAMAGE TO THE ENGINE.



Environmental Compliance

Lycoming Engines recommends that engine owners and engine service personnel be in compliance with all federal, state, and local environmental regulations when solvents, paint, fuel, oil, chemicals, or other consumables are used in engine service.

Warnings, Cautions, and Notices

Be sure to read and obey the Warnings, Cautions, and Notices in this manual and in service documents. Although Lycoming Engines cannot know all possible hazards or damages, it makes a reasonable effort to supply the best known guidance and recommended practices for safe operation and maintenance of its engines.

The table below defines the four types of safety advisory messages used in this manual as per the American National Standard and ANSI Z535-6-2006.

Safety Advisory Conventions	
Advisory Word	Definition
<u>DANGER:</u>	Indicates a hazardous situation which, if not avoided, will result in death or serious injury. This signal word is to be limited to the most extreme situations.
 <u>WARNING</u>	Indicates a hazardous situation which, if not avoided, could result in death or serious injury.
 <u>CAUTION</u>	Indicates a hazardous situation which, if not avoided, could result in minor or moderate injury. It also can be used without the safety alert symbol as an alternative to " NOTICE. "
<u>NOTICE:</u>	The preferred signal word to address practices not related to personal injury.

NOTICE: In this manual, the word "recommend" refers to "best practices."

Service Bulletins, Service Instructions, and Service Letters

As advancements in technological applications on this engine continue, Lycoming will make future revisions to this manual. However, if more timely distribution is necessary, Lycoming supplies up-to-date Service Bulletins (SBs), Service Instructions (SIs) and Service Letters (which are abbreviated with a capital "L" followed by the number, example L180). Special Advisories (SAs) are supplied as necessary.

For additional publication information, look on Lycoming's website (Lycoming.com) or speak to Lycoming Engines by telephone: U.S. and Canada toll free: +1(800) 258-3279; or Direct: +1 (570) 323-6181.

Applicable information from Lycoming Engines' Service Bulletins, Service Instructions, and Service Letters are included in this manual at the time of publication. Any new service information will be included in the next update of the manual.

Reminder: Unless otherwise specified, Lycoming Engines' service documents (which are dated after this manual's release date) that pertain to the engine model in this manual supersede procedures in this manual.

For reference, the Service Document List at the front of this manual shows the service documents referenced or included in this manual.

List of Publications

Refer to the latest revision of Service Letter No. L114 for a list of Lycoming Engines' publications.

Simplified Technical English

The text in the manual is written in the form of Simplified Technical English in compliance with FAA requirements and to make translation into other languages easier.

Format

Chapters in this manual are identified in Air Transport Association (ATA) format.

Figures

Figures in this manual are for illustration purposes only. Figures always start as Figure 1 in each chapter.

Tables and Checklists

Tables in this manual are used to display detailed information in an organized format. Tables always start as Table 1 in each chapter. Checklists are used to display a list of tasks to be completed as part of a specific procedure. Checklists are not numbered because they are used as a reference tool contained within the procedure.

Copyright

This publication is a copyrighted work. All rights reserved by Lycoming Engines. Content in this manual cannot be changed or released as a reprint, electronic media output, or web communiqué without written permission from Lycoming Engines.

Feedback

To supply comments, suggestions, or corrections to this manual, either email or contact Lycoming Engines Technical Support at the email or phone number in the front of this manual or use the Lycoming.com website.

Manual Revisions

Lycoming Engines constantly examines our manuals to provide our customers the most complete and up-to-date information for operating and maintaining our engines. Revisions to this manual will be published as necessary.

Patents

The following patents apply to the engine and control systems:

- 7,658,184
- 7,875,989
- 7,827,965
- 8,131,406
- 7,828,509

This page intentionally left blank.

AIRWORTHINESS LIMITATIONS

1. General


This Airworthiness Limitations chapter sets forth each mandatory replacement time, inspection interval, and related procedure required for type certification. The Airworthiness Limitations section is FAA approved and specifies maintenance required under 14 CFR §§ 43.16 and 91.403 of the Federal Aviation Regulations (FAR) unless an alternative program has been FAA-approved.

2. Mandatory Inspection - Exhaust Valve and Guide

At every 1000 hours of operation for TEO-540-A1A engines, examine the exhaust valve and guide conditions. Refer to the section "Exhaust Valve and Guide Inspection" in Chapter 72-30.

3. Mandatory Inspection – EECS NTO Faults

Take-off is prohibited with Electronic Engine Control System No Take-Off Faults annunciated. The NTO annunciator indicates engine control fault(s) exists that exceed 14 CFR Part 33 limitations; the engine is not airworthy with the NTO annunciator illuminated. The fault(s) must be identified, the condition corrected, and the fault(s) cleared before take-off.

Approved by: 
Anthony E. Gallo
Manager, New York ACO Branch
Federal Aviation Administration
Date: NOV 01 2018

This page intentionally left blank.

05-00 - REQUIRED MAINTENANCE

1. Required Maintenance

Required maintenance on these engines includes: oil changes, oil addition, oil filter replacement, routine time-interval inspections, routine service, spark plug replacement/inspection procedures, cylinder inspection, fuel system inspection and other procedures identified in the checklists in Chapter 05-20 of this manual.

2. General

In addition to instructions for required service and maintenance of the Lycoming TEO-540-A1A engine, this manual also includes airworthiness limitations, fault isolation guidelines and procedures for component replacement, engine disassembly and engine assembly. Refer to the *TEO-540-A1A Illustrated Parts Catalog* to identify spare parts.

A. Refer to the latest revision of the *Service Table of Limits - SSP-1776*, for dimensions, clearances, measurements, and torque values.

B. Engine description, uncrating procedures, acceptance check, engine lift procedure, engine preservation and storage, depreservation, engine installation requirements, engine installation, engine start, operation, and stop procedures, engine initiation (break-in/flight test), fuels and oil to be used, and operating specifications are included in the *TEO-540-A1A Engine Installation and Operation Manual*.

3. List of Tools for Service and Maintenance

Table 1 identifies tools used for service and maintenance.

Table 1
Tools for Service and Maintenance

Tool	Purpose
Champion Tool CT-470	Cut open oil filter
Borescope	Cylinder Borescope Inspection
Aviation Mechanic's Tools	
Differential Compression Tester	Cylinder Compression Check
Baffle Retainer Hook	
Plug Gage	Measure inner diameter of the valve guide
Imada DPS-220R or equivalent	Spring Tester - Available from Tool Vendor
Dial Bore Gage	Measure cylinder diameter
Thickness Gage	Measure paint coating thickness
Arbor Press Spindle	Counterweight bushing removal
ST-23	Gage, Valve Clearance 0.028 to 0.080 in.
ST-25	Compressor, Valve Spring
ST-92	Counterweight Bushing Driver
ST-93	Counterweight Fixture Assembly
ST-93-3	Depth Control Spacer
ST-93-5	Depth Control Spacer
ST-115	Tool, Install and Remove Propeller Flange Bushings
ST-131	Belt Tension Dial Gage
ST-172	Seal Puller

**Table 1 (Cont.)
Tools for Service and Maintenance**


Tool No.	Nomenclature and Description
ST-210	Reamer, .0075 o/s Counterweight Bushing Holes (for Lug Bushings per S.I. 1142)
ST-211	Reamer, .0125 o/s Counterweight Bushing Holes (for Lug Bushings per S.I. 1142)
ST-280	Fixture, Ream Crankshaft Counterweight (for Lug Bushings per S.I. 1142)
ST-222	Plate, Torque Hold-Down
ST-271	Puller, Crankcase Thru-Stud
ST-310	Gage, Check Bell-Mouthing of Exhaust Valve Guides
ST-310-9	Gage Adapter
ST-317	Driver, Crankcase Thru-Stud
ST-383	Tool, Crankshaft Oil Seal Installation
ST-389	Tool, Crankcase Separating
ST-483	Test Plate
ST-528	iE ² Service Cable
ST-530	iE ² Field Service Tool CAN Interface
ST-532	Idle Gear Assembly Aid
ST-533	Fuel Pump Drive Shaft Indicator Mount
ST-534	Crankshaft Locking Tool
ST-535	Special Socket, Spark Plug Wire Nut
64526-2	Block, Cylinder
64530	Connecting Rod Parallelism and Squareness Gage
64535	Connecting Rod Bushing Removal Drift
64536	Replacement Drift
64580	Connecting Rod Bushing Burnisher
64593	Expanding and Staking Tool, 0.71 in. (18 mm) Spark Plug Heli-Coil [®] Insert
64594	Inserting Tool, 18 MM Spark Plug Heli-Coil [®] Insert
64595	Removing Tool, 18 MM Spark Plug Heli-Coil [®] Insert
64596-1	Tap, 18 mm Heli-Coil [®] Spark Plug Bottom Tap 0.010 in. (0.254 mm) OS
64597	Connecting Rod Bushing Replacement Block
64681	Driver, Crankshaft Welch Plug (for expansion plug)
64712	Compressor, Piston Ring
64713	Expander, Piston Ring
64767	Finish ID Gage (for connecting rod bushing)
64781	Swaging Tool
64872	Puller, Remove and Install Crankshaft Counterweight Bushings
64874	Reamer, 0.005 o/s Counterweight Bushing Holes (for Lug Bushings per S.I. 1142)
64875	Reamer, 0.010 o/s Counterweight Bushing Holes (for Lug Bushings per S.I. 1142)
64876	Reamer, 0.015 o/s Counterweight Bushing Holes (for Lug Bushings per S.I. 1142)
64892-2	Circlip Check Gage
64941	Tappet Assembly Tool
FST	iE ² Field Service Tool Software (Downloadable from www.lycoming.com)

4. Time Between Overhaul (TBO)

Refer to the latest revision of Service Instruction No. SI-1009 for any changes or special circumstances for the recommended TBO.

Lycoming Engines recommends engines be sent to the factory for overhaul.

5. Safety Precautions - Before Engine Maintenance

 **WARNING** BEFORE THE START OF ANY SERVICE OR MAINTENANCE ON AN INSTALLED ENGINE OR AN ENGINE ON A TEST STAND CONNECTED TO POWER, ENSURE THE IGNITION SWITCH IS TURNED OFF AND DISABLED. DISCONNECT ALL POWER TO THE ENGINE TO PREVENT ACCIDENTAL ENGINE START-UP. FAILURE TO DISABLE POWER COULD CAUSE ACCIDENTAL ENGINE START-UP, INJURY, OR DEATH. ENSURE ALL OBJECTS/PERSONNEL ARE CLEAR OF THE PROPELLER'S ROTATIONAL ARC. IF POWER IS ON, A LOOSE OR BROKEN WIRE CAN CAUSE THE ENGINE TO START AND THE PROPELLER TO TURN WHICH CAN LEAD TO DEATH OR SERIOUS INJURY OR A PROPELLER STRIKE.

IF IT IS NECESSARY TO COMPLETE OPERATIONAL TESTS ON THE ENGINE WITH POWER ON, KEEP ALL PERSONNEL AWAY FROM THE ROTATIONAL RADIUS OF THE PROPELLER TO PREVENT INJURY OR DEATH ON ENGINE START-UP.

- A. Disconnect the battery.
- B. Pull and attach a tag to the Electronic Engine Control System (EEEC) Power circuit breaker.
- C. Remove access panel(s), cowling(s) and/or baffles for access to areas.

6. Maintenance Practices

- A. Obey all safety precautions.
- B. Unless otherwise directed do not reuse a gasket, O-ring, or seal. Install a new gasket, O-ring, or seal during component installation where a gasket, O-ring, or seal was removed.
- C. If maintenance is done that could cause contamination of the internal components of the engine, complete the "Oil Change Procedure" in Chapter 12-10.
- D. Remove all traces of dirt, dust, debris and accumulated matter from parts. All parts must be clean before they are installed on the engine. For specific cleaning guidelines, refer to Chapter 05-30.
- E. If adhesive tape has been applied to any part, remove the tape and all residue. Clean the part completely.
- F. Hardware
 - (1) All cotter pins that are removed must be discarded and not reused. Install a new cotter pin where a cotter pin was removed.
 - (2) All safety wire and cotter pins must be made of corrosion-resistant steel and installed as a snug fit in holes in studs and bolts for correct locking.
 - (3) If safety wire or safety cable was removed during component removal, be sure to install new safety wire or safety cable during component installation.

- (4) All safety cable installed on the engine must meet or exceed specifications in the latest revision of AS3510. Safety cable must be installed per the safety cable manufacturer's instructions and in accordance with specifications in the latest revisions of AS4536 and AS567 and the latest revision of Service Instruction No. SI-1566.
 - (5) The cotter pin head must install as a snug fit into the castellation of the nut. Unless otherwise specified, bend one end of the cotter pin back over the stud or bolt and the other end flat against the nut.
 - (6) Torque a castellated or slotted nut to the value specified in this manual or the latest revision of the *Service Table of Limits - SSP-1776*, if necessary, turn the nut up to one additional hex to align the slot in the nut with the hole in the bolt.
 - (7) If a lockplate is required when installing a bolt, torque the nut to the value specified in this manual or the latest revision of the *Service Table of Limits - SSP-1776*. If necessary, turn the nut up to one additional hex to align the flat on the nut with the tab on the lockplate. Lockplate tabs must not be bent up on the corner of the nut.
 - (8) Replace any damaged or unserviceable hardware, fasteners, studs, screws, bolts, nuts, washers, and clamps with new parts.
 - (9) Always replace lock washers and lock nuts with new lock washers and lock nuts.
 - (10) Although the latest revision of Service Bulletin No. SB-240 identifies parts which must be replaced after they are removed, in the case where other parts are removed, it is recommended practice, prior to installation, to examine each part for damage or wear and replace the part as needed in accordance with accepted practices and standards to ensure that serviceable parts are installed on the engine.
- G. Unless otherwise specified in this manual, refer to the latest revision of the *Service Table of Limits - SSP-1776* for:
- Standard torque values for fittings, plugs, and hardware fasteners
 - Special torque requirements for fittings, valves, clamps, couplings, plugs, and other hardware fasteners in various locations on the engine
 - Dimensions
 - Clearances
 - Measurements
- H. Specific engine parts must be lubricated prior to installation. If parts are not correctly lubricated, or if an unapproved lubricant is used, engine parts could become scored before the engine oil has lubricated the engine during the first cycle of operation. This scoring can cause premature part failure, or, in some cases, engine failure. As preventive action, during engine component replacement, apply the approved lubricant for specified components identified in the latest revision of Service Instruction No. SI-1059.
- I. If an engine start is required to complete a maintenance procedure, make sure that if you do not see oil pressure (greater than 0) indication within 10 seconds after engine start or oil pressure does **not** continue to increase above the published minimum pressure in the next 20 seconds, stop the engine. Identify and correct the problem before another engine start.
- J. Complete the Operational Ground Check prior to and after each inspection, after maintenance, and engine assembly. Refer to Chapter 72-00.

7. General Engine Inspection Criteria


During visual inspection:

- Replace the crankcase, oil sump, or accessory housing if there is any raised metal on surfaces
- Replace the crankcase, oil sump, or accessory housing if there is any scratch, ding, dent, or pit, that exceeds 0.050 in. (1.27 mm) depth
- Replace the crankcase if the dowels do not fully seat into the crankcase holes
- Replace any bent, damaged, or stripped studs, refer to Appendix A

8. Requirements for Engine Maintenance

- A. These engines must be maintained using Lycoming Engines' approved methods and procedures.
- B. Refer to the latest revision of Service Bulletin No. SB-240 for a list of parts that must be replaced whenever they are removed.

9. Approved Parts

 **CAUTION** LYCOMING DOES NOT GIVE APPROVAL FOR USE OF PARTS MANUFACTURER APPROVAL (PMA) PARTS ON ITS ENGINES. LYCOMING INSTALLATION INSTRUCTIONS DO NOT APPLY TO PMA PARTS. EQUIPMENT FAILURE COULD OCCUR IF LYCOMING INSTRUCTIONS ARE USED TO INSTALL PMA PARTS. DAMAGES RELATED TO THE INSTALLATION OF PMA PARTS COULD VOID THE WARRANTY.

Lycoming Engines recommends these engines be maintained using only genuine Lycoming parts (PMA parts have not been approved for use by Lycoming Engines).

Refer to the *TEO-540-A1A Illustrated Parts Catalog* for genuine Lycoming parts.

Before installing a component, complete a check of the shelf-life of the part as per the latest revision of Service Letter No. L247.

This page intentionally left blank.

05-10 - TIME LIMITS / INSPECTIONS

1. Engine Inspection Schedule for TEO-540-A1A Engines
 - A. As shown in the Engine Inspection Schedule below, the scope of engine inspections includes visual observations during engine servicing or maintenance as well as inspections based on progressive time intervals after the engine is put into service.
 - B. All engine inspections are mandatory and must be completed no later than 10 hours after the specified time interval for the inspection. Refer to FAR 91.409 for additional requirements.

NOTICE: More frequent inspections could be necessary for engines operated in particulate-laden or extremely humid, cold, damp environments.

Inspections in this manual apply to the engine and not to the aircraft. Refer to the aircraft manufacturer's maintenance manual for inspection information on aircraft components. For all engine accessory inspections, refer to the individual service requirements from each manufacturer and Supplemental Type Certificates (STCs).

Engine Inspection Schedule for TEO-540-A1A Engines	
When to Complete Inspection	Refer to Chapter 05-20
Before each time-interval inspection and during engine servicing or maintenance	Visual Inspection
Initial 10-hour engine inspection	10-Hour Initial Engine Inspection
<ul style="list-style-type: none"> • After the first 25 hours of operation or the first 4 months since the engine was placed into service (whichever occurs first) • If one or more new engine cylinders and/or piston rings have been installed • If the rate of oil consumption has not stabilized. 	25-Hour Engine Inspection
After every 50 hours of operation or every 4 months	50-Hour Engine Inspection
After every 100 hours of operation or annually	100-Hour or Annual Engine Inspection
After every 250 hours of operation	250-Hour Engine Inspection
After every 400 hours of operation	400-Hour Engine Inspection
After every 1000 hours of operation	1000-Hour Engine Inspection
Time Between Overhaul (TBO) Lycoming Engines recommends engines be sent to the factory for overhaul.	Refer to the latest revision of Service Instruction No. SI-1009 for any changes or special circumstances for the recommended TBO.

NOTICE: An operational ground check must be completed prior to and after each inspection and after maintenance. Refer to Chapter 72-00.

This page intentionally left blank.

05-20 - REQUIRED ENGINE INSPECTIONS FOR TEO-540-A1A ENGINES

1. Engine Inspections


- A. As shown in the Engine Inspection Schedule in Chapter 05-10, the scope of engine inspections includes visual observations during engine servicing or maintenance as well as inspections based on progressive time intervals after the engine is put into service.
- B. All engine inspections are mandatory and must be completed no later than 10 hours after the specified time interval for the inspection. Refer to FAR 91.409 for additional requirements.

NOTICE: More frequent inspections could be necessary for engines operated in particulate-laden or extremely humid, cold, damp environments.

Obey and follow inspection checklists and instructions in this chapter in addition to maintenance guidelines from the aircraft manufacturer or component manufacturers that have a Supplemental Type Certificate (STC).

2. Visual Inspection for TEO-540-A1A Engines

- A. Complete the Visual Inspection, with the engine installed in the aircraft, before each routine 25, 50, 100, 250, 400, and 1000-hour inspection and every time before you service, maintain, or clean the engine.


 **WARNING** BEFORE ANY ENGINE INSPECTION OR SERVICE PROCEDURE, MAKE SURE THE IGNITION SWITCH IS SET TO OFF AND THAT ALL POWER TO THE ENGINE IS DISCONNECTED. ENSURE ALL OBJECTS/PERSONNEL ARE CLEAR OF THE PROPELLER'S ROTATIONAL ARC. IF POWER IS ON, A LOOSE OR BROKEN WIRE CAN CAUSE THE ENGINE TO START AND THE PROPELLER TO TURN WHICH CAN LEAD TO A PROPELLER STRIKE, SERIOUS INJURY, OR DEATH.

B. Required tools:

Refer to Table 1 – “Tools for Service and Maintenance” in Chapter 05-00.

C. Visual Inspection

- (1) Set all ignition and electrical switches to the OFF position.
- (2) Per the aircraft manufacturer's instructions, remove the engine cowling from the aircraft for access to the engine and its compartment.

 **WARNING** IF VOLCANIC ASH IS SUSPECTED ON THE ENGINE, DO NOT TOUCH IT WITH BARE HANDS OR GET IT IN YOUR EYES. WEAR PERSONAL PROTECTIVE EQUIPMENT. DO NOT USE WATER TO RINSE IT OFF. VOLCANIC ASH CAN CONTAIN ACIDIC COMPOUNDS WHICH MUST NOT BE INHALED OR TOUCHED SINCE IT CAN CAUSE INJURY. REFER TO THE "VOLCANIC ASH REMOVAL" PROCEDURE IN CHAPTER 05-30.

- (3) Copy and complete the Visual Inspection Checklist in this chapter for TEO-540-A1A engines each time this inspection is done as a record of engine service. Record the engine hours.

Visual Inspection Checklist for TEO-540-A1A Engines

Engine Serial Number: _____ Engine Time: _____

Date Inspection Done: _____ Inspection done by: _____

Item	Comments	Findings/ Corrective Action	Done
Engine Compartment			
Look for and remove unwanted dirt, dust, sand, or particles on the engine and in its compartment.			
If the engine has been exposed to volcanic ash, examine for volcanic ash and particulate contamination.	Refer to the “Volcanic Ash/Particulate Contamination” section in Chapter 05-50.		
Examine all hoses, lines, connections, wiring, fittings, and baffles for loose connections and any damage.	Tighten any loose hardware as per the Standard Torque Tables in the latest revision of the <i>Service Table of Limits - SSP-1776</i> . Replace field-serviceable damaged components. Otherwise, send the engine to Lycoming Engines or an FAA authorized repair facility for repair.		
Examine the cowling and baffles for damage and correct installation	Replace damaged cowling or baffles in accordance with aircraft manufacturer’s instructions.		
Examine the cowling, engine and its compartment for evidence of fluid leaks, residues, or discoloration.	Identify and correct the cause of any leak, residue or discoloration.		
Examine the intercylinder baffles for damage or looseness.	Refer to “Intercylinder Baffle Inspection” procedure in Chapter 72-30.		

Visual Inspection Checklist for TEO-540-A1A Engines (Cont.)			
Item	Comments	Findings/ Corrective Action	Done
Lubrication System			
Examine the oil pressure relief valve, oil cooler bypass valve, oil filter and oil sump drain plugs to verify they are in satisfactory condition. Ensure that all components are secure on their respective mountings, all associated hose connections are secure and that there is no evidence of leakage.	Refer to Chapters 12-10 and 72-50. Identify and correct the cause of any leak.		
Make sure the safety wire or safety cable is secure and correctly installed on the oil cooler bypass valve, oil filter and oil sump drain plug(s).	Refer to Chapters 12-10 and 72-50.		
Examine all oil hoses for leaks, wear, and secure attachment. Make sure that all hoses and associated cushion clamps are secure and cannot move or vibrate excessively. Ensure that there are no sharp bends in the oil hose routing and that no hoses are near heat sources that could damage them.	Identify and correct the cause of any leak. Refer to the "Oil Hose Inspection" procedure in Chapter 72-50. Correct any problem before flight to make sure the engine operates correctly to specifications in the <i>TEO-540-A1A Engine Installation and Operation Manual</i> .		
Fuel System			
Examine all fuel hoses for leaks, wear, and secure attachment. Make sure that all fuel hoses have cushioned clamps securely attached to hold the fuel hoses securely in place to prevent excessive vibration. Make sure that there are no sharp bends in the fuel hose routing and that the fuel hoses are not near heat sources that could damage the fuel hose.	Identify and correct the cause of any leak. Refer to the "Fuel Hose Inspection" procedure in Chapter 73-10.		

Visual Inspection Checklist for TEO-540-A1A Engines (Cont.)

Cylinders - Refer to Figures in Chapter 72-30.

Item to Examine	Cyl. 1	Cyl. 2	Cyl. 3	Cyl. 4	Cyl. 5	Cyl. 6
NOTICE: During the first hours of service, engines can have some leakage at the cylinder base or the cylinder base studs. This initial leakage is not harmful or detrimental to the engine.						
Exhaust or combustion residue - Identify and correct the cause.						
Examine the cylinders for heat damage i.e. burnt paint and damaged fins. (Identify whether the paint has scaled or peeled from discolored and blistered paint appearance. Unburned metallic surfaces appear bright or clean with definite edges.) - Identify and correct the cause.						
Examine the exhaust system, exhaust flange and port connections for leaks in connections between the exhaust system and exhaust ports of cylinders - look for burnt paint around the spark plug and exhaust flange bosses or for light gray deposits near the leaks; look for a warped exhaust flange (which can cause a leak.) - Identify and correct the cause. Replace exhaust pipes that have a warped flange.						
Examine studs on the cylinder head for looseness or damage. Replace loose or damaged studs.						
Examine the following for cracks, rust/pitting and damage - replace cracked, rusted, pitted or damaged cylinders per instructions in Chapter 72-30.						
External cylinder barrel and cooling fins.						
External surface of the cylinder head and fins including areas between and adjacent to the fins.						
Look for any radial fin crack extending to the root of a fin on the cylinder.						
Top and bottom spark plug bosses.						
Follow-Up Action:						

Visual Inspection Checklist for TEO-540-A1A Engines (Cont.)			
Item	Comments	Findings/ Corrective Action	Done
Crankcase			
Examine the external surface of the crankcase for damage and cracks per the “Exterior Crankcase Inspection” in Chapter 72-20.			
Accessories and Accessory Housing			
Examine the accessory housing and its attached accessories for damage.	Replace damaged accessories or accessory housing per Chapter 72-25. Replace the accessory housing if there is any raised metal on surfaces. Replace the accessory housing if there is any scratch, ding, dent, or pit that exceeds 0.050 in. (1.27 mm) depth.		
Visually examine the alternator, alternator belt, and attaching hardware.	Refer to Chapter 72-70.		
Wiring Harness			
Make sure that the Engine Control Unit (ECU), Power Box, Data Logger (if applicable) and engine ground straps are attached correctly and tightly. Examine the ECU, Power Box, and associated connectors for secure attachment and signs of damage.	Replace any damaged component per procedures in Chapter 72-70. Tighten any loose fastening hardware.		
Make sure that the securing straps, safety wire (lockwiring) (at the sensor connectors) and the ECU connectors are attached correctly and tightly.	Refer to Chapter 72-70.		
Examine the wiring harness and electrical connectors. Look for loose or damaged connectors, broken or frayed wire, signs of chafing, deterioration, abrasion or heat-related damage.	Refer to the “Wiring Harness Inspection” procedure in Chapter 72-70. Replace the wiring harness if it is frayed, broken, chafed, abraded, or damaged.		

Visual Inspection Checklist for TEO-540-A1A Engines (Cont.)			
Item	Comments	Findings/ Corrective Action	Done
Wiring Harness (Cont.)			
Examine electrical connectors for evidence of corrosion.	If corrosion is found, disconnect, examine the connector, and clean or replace the connector as required.		
Make sure the wiring harnesses are routed correctly and attached securely and that there are no broken, chafed or frayed wires or damaged/broken sensors or connectors.	Refer to Chapter 72-70. Replace the wiring harness if a wire is broken, frayed or chafed or if a sensor connector is broken or damaged. Refer to Appendix B in this manual for wiring harness connections.		
Ensure that all engine wiring harness cushion clamps are secure and not worn or damaged.	Tighten any loose clamps. Replace any worn or damaged clamps.		
Turbocharger			
Examine all V-band clamps to ensure they are tight and undamaged.	Refer to Chapter 72-40.		
Make sure that all exhaust heat shields are secure and undamaged.			
Induction System			
Make sure that the induction system is in satisfactory condition. Ensure that all clamps and hardware are securely fastened and that there is no evidence of leakage or staining.	Refer to the "Induction System Inspection" in Chapter 72-80.		
In accordance with the aircraft manufacturer's instructions, examine the induction air filter for cleanliness, security, and indications of damage.			

Visual Inspection Checklist for TEO-540-A1A Engines (Cont.)			
Item	Comments	Findings/ Corrective Action	Done
Engine Controls			
Examine all engine controls for general condition, full travel, and freedom of operation in accordance with the aircraft manufacturer's instructions			
Look for any illuminated NTO, TLO, or FFL lights.	Refer to the Troubleshooting Guide in Appendix D of this manual to identify the fault and complete the Troubleshooting Steps.		
Follow-Up Action:			

- (4) Make sure any items removed during inspection, in the engine compartment, are securely in place and not loose. Remove any foreign object debris (FOD) from the engine compartment.
- (5) Start the engine and run-up per instructions in the "Engine Initiation" chapter of the *TEO-540-A1A Engine Installation and Operation Manual*.
- (6) Operate the engine for 3 minutes on the ground (per the *TEO-540-A1A Engine Installation and Operation Manual*.) Complete a leak check while the engine is in operation.
- (7) Shut down the engine and proceed with the routine inspection or engine service.
- (8) Copy and complete the Operational Leak Checklist for TEO-540-A1A engines on the next page.
- (9) Identify and correct all leaks. Record all leaks and corrective action on the Operational Leak Checklist for TEO-540-A1A Engines.
- (10) Re-install the engine cowling per the aircraft manufacturer's instructions.

Operational Leak Checklist for TEO-540-A1A Engines

Engine Serial Number: _____ **Engine Time:** _____

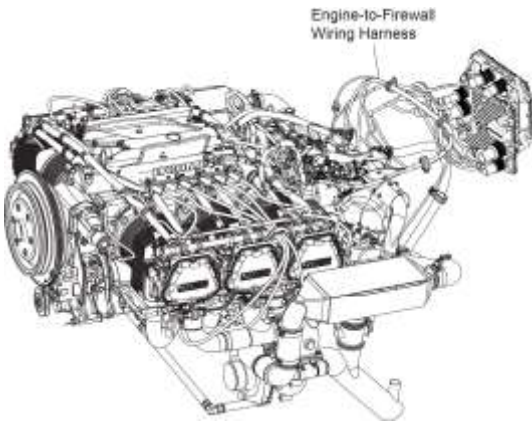
Date Inspection Done: _____ **Inspection done by:** _____

Item	Comments	Findings/ Corrective Action	Done
Examine the cowling, engine and its compartment for evidence of fluid leaks, residue, or discoloration.	Identify and correct the cause of any leak, residue, or discoloration.		
Examine all oil hoses for leaks, wear, and secure attachment. Make sure that the oil hoses are secure and not vibrating. Make sure that there are no sharp bends in the oil hose routing and that the oil hoses are not near heat sources that could damage the oil hose.	Identify and correct the cause of any leak. Refer to the “Oil Hose Inspection” procedure in Chapter 72-50.		
Examine all fuel hoses for leaks, wear, and secure attachment. Make sure that all fuel hoses have cushioned clamps securely attached to hold the fuel hoses securely in place to prevent excessive vibration. Make sure that there are no sharp bends in the fuel hose routing and that the fuel hoses are not near heat sources that could damage the fuel hose.	Identify and correct the cause of any leak. Refer to the “Fuel Hose Inspection” procedure in Chapter 73-10.		

3. 10-Hour Initial Engine Inspection for TEO-540-A1A Engines
 - A. Complete this inspection after the first 10 hours of initial operation of the engine.
 - B. Copy and complete the 10-Hour Initial Engine Inspection Checklist for TEO-540-A1A engines as a record of engine service. Record the engine hours.

⚠ WARNING BEFORE ANY ENGINE INSPECTION OR SERVICE PROCEDURE, MAKE SURE THE IGNITION SWITCH IS SET TO OFF AND THAT ALL POWER TO THE ENGINE IS DISCONNECTED. ENSURE ALL OBJECTS/PERSONNEL ARE CLEAR OF THE PROPELLER'S ROTATIONAL ARC. IF POWER IS ON, A LOOSE OR BROKEN WIRE CAN CAUSE THE ENGINE TO START AND THE PROPELLER TO TURN WHICH CAN LEAD TO A PROPELLER STRIKE, SERIOUS INJURY, OR DEATH.

NOTICE: Copy the blank checklist and complete this checklist as a record of engine maintenance. Put the completed checklist in the engine logbook.

10-Hour Initial Engine Inspection Checklist for TEO-540-A1A Engines			
Engine Serial Number: _____		Engine Time: _____	
Date Inspection Done: _____		Inspection done by: _____	
Inspection Item	Comments	Results/Notes	Done
Examine the Engine-to-Firewall Wiring Harness (Figure 1). Ensure that its connectors are attached correctly and not damaged.	Tighten any loose items on the wiring harness. Refer to the "Wiring Inspection" procedure in Chapter 72-70.		
Examine Firewall-to-ECU/Power Box Wiring Harness (Figure 1). Examine the wiring connection to the Data Logger (if applicable).	Tighten any loose items on the wiring harness. Refer to the "Wiring Inspection" procedure in Chapter 72-70.		
 <p>Figure 1 Engine-to-Firewall Wiring Harness</p>			

10-Hour Initial Engine Inspection Checklist for TEO-540-A1A Engines (Cont.)

Inspection Item	Comments	Results/Notes	Done
Complete the Operational Ground Check in Chapter 72-00.	Look for leaks. Identify and correct the cause of any leak. Correct any problem to make sure the engine operates correctly to specifications in Appendix A of the <i>TEO-540-A1A Engine Installation and Operation Manual</i> .		



4. 25-Hour Engine Inspection for TEO-540-A1A Engines
 - A. The purpose of this inspection is to measure the oil level and oil consumption, replace the oil filter, complete an initial oil change, identify and correct the cause of any oil leak.
 - B. Complete this 25-Hour Engine Inspection at the following times:
 - After 25 hours of engine operation or the first 4 months since the engine was placed into service (whichever comes first) per Chapter 12-10
 - 25 hours after one or more new engine cylinders and/or piston rings have been installed
 - If the rate of oil consumption has not stabilized

NOTICE: Refer to the “Oil Servicing Schedule” in Chapter 12-10.

- C. Copy and complete the 25-hour Engine Inspection Checklist for TEO-540-A1A engines as a record of engine service. Record the engine hours.

⚠ WARNING BEFORE ANY ENGINE INSPECTION OR SERVICE PROCEDURE, MAKE SURE THE IGNITION SWITCH IS SET TO OFF AND THAT ALL POWER TO THE ENGINE IS DISCONNECTED. ENSURE ALL OBJECTS/PERSONNEL ARE CLEAR OF THE PROPELLER’S ROTATIONAL ARC. IF POWER IS ON, A LOOSE OR BROKEN WIRE CAN CAUSE THE ENGINE TO START AND THE PROPELLER TO TURN WHICH CAN LEAD TO A PROPELLER STRIKE, SERIOUS INJURY, OR DEATH.

25-Hour Engine Inspection Checklist for TEO-540-A1A Engines			
Engine Serial Number: _____		Engine Time: _____	
Date Inspection Done: _____		Inspection done by: _____	
Inspection Item	Comments	Results/Notes	Done
Complete the Visual Inspection Checklist in this chapter.	Refer to the section “Visual Inspection for TEO-540-A1A Engines” in this chapter.		
Complete the Operational Ground Check in Chapter 72-00.	Make sure the engine operates correctly to specifications.		
Measure and record the oil level.	Refer to the section “Oil Level Check” in Chapter 12-10.		
Calculate oil consumption.	Refer to the “Oil Consumption” section in Chapter 12-10 Complete this 25-hour inspection again, as needed, until oil consumption stabilizes.		
Complete an initial oil change.	Refer to the section "Oil Change Procedure" in Chapter 12-10.		

25-Hour Engine Inspection Checklist for TEO-540-A1A Engines (Cont.)			
Inspection Item	Comments	Results/Notes	Done
 WARNING EXAMINE THE FILTER ELEMENT OF THE OIL FILTER FOR UNWANTED METAL PARTICLES.			
Remove, examine, and replace the oil filter on the initial oil change.	Complete the “Oil Filter Replacement” “Oil Filter Inspection” procedures in Chapter 12-10.		
 WARNING EXAMINE THE OIL SUMP SUCTION SCREEN AND FOR UNWANTED METAL PARTICLES. REMOVE ANY CLOGS OR BLOCKAGES IN THE SUCTION SCREEN.			
NOTICE: For engines with any newly installed cylinders, at 25 hours after the first oil suction screen cleaning/inspection, complete an oil change and oil filter replacement.			
Remove, examine and clean the oil suction screen at the oil sump; install the oil suction screen.	If blockage is found, record and identify the blockage (metal, carbon, etc.) Remove any blockage and clean the oil suction screen. Refer to the section “Oil Suction Screen Removal/Inspection/Cleaning/Installation” in Chapter 12-10.		
Examine the engine for fuel or oil leaks. NOTICE: During the first hours of service, engines can have some leakage at the cylinder head. This initial leakage is not harmful or detrimental to the engine.	Complete the “Oil Leak Check” procedure in Chapter 12-10.		
Examine the engine for dirt, particulate, sand, or other contamination.	Remove any dirt, particulate, sand, or other contamination per Chapter 05-30.		
Re-torque the exhaust flange nuts after the first 25-hours of engine operation.	Refer to the latest revision of the <i>Service Table of Limits - SSP-1776</i> .		
General			
Identify and correct the cause of any fuel or oil leaks or other discrepancies before returning the engine to service.			
Complete the Operational Ground Check in Chapter 72-00.	Correct any problem before flight to make sure the engine operates correctly to specifications.*		
*Appendix A of the <i>TEO-540-A1A Engine Installation and Operation Manual</i> .			

5. 50-Hour Engine Inspection for TEO-540-A1A Engines

- A. The purpose of this inspection is to make sure that the engine operates correctly.
- B. Complete the 50-Hour Engine Inspection after every 50 hours of engine operation or every 4 months (whichever occurs first).
- C. Copy and complete the 50-hour Engine Inspection Checklist for TEO-540-A1A Engines as a record of engine service. Record the engine hours.

⚠ WARNING BEFORE ANY ENGINE INSPECTION OR SERVICE PROCEDURE, MAKE SURE THE IGNITION SWITCH IS SET TO OFF AND THAT ALL POWER TO THE ENGINE IS DISCONNECTED. ENSURE ALL OBJECTS/PERSONNEL ARE CLEAR OF THE PROPELLER’S ROTATIONAL ARC. IF POWER IS ON, A LOOSE OR BROKEN WIRE CAN CAUSE THE ENGINE TO START AND THE PROPELLER TO TURN WHICH CAN LEAD TO A PROPELLER STRIKE, SERIOUS INJURY, OR DEATH.

50-Hour Engine Inspection Checklist for TEO-540-A1A Engines			
Engine Serial Number: _____		Engine Time: _____	
Date Inspection Done: _____		Inspection done by: _____	
Inspection Item	Comments	Results/Notes	Done
Complete the Visual Inspection Checklist in this chapter.	Refer to the section “Visual Inspection for TEO-540-A1A Engines” in this chapter.		
Complete the Operational Ground Check in Chapter 72-00.	Make sure the engine operates correctly to specifications.*		
Calculate oil consumption.	Refer to the “Oil Consumption” section in Chapter 12-10 Complete the 25-hour inspection again until oil consumption stabilizes.		
Complete an oil change and oil filter replacement.	Refer to the sections in Chapter 12-10: <ul style="list-style-type: none"> • "Oil Change Procedure" • “Oil Filter Replacement” • “Oil Filter Inspection” 		
*Appendix A of the <i>TEO-540-A1A Engine Installation and Operation Manual</i> .			

50-Hour Engine Inspection Checklist for TEO-540-A1A Engines (Cont.)			
Inspection Item	Comments	Results/Notes	Done
Remove, examine, clean and install the oil suction screen at the oil sump. Replace the oil suction screen if distorted, deformed or open areas are found in the mesh.	Refer to the section in Chapter 12-10: "Oil Suction Screen Removal/Inspection/Cleaning/Installation."		
Look for any fuel or oil leaks before cleaning the engine.	Identify and correct the cause of any leak.		
Wipe dirt from the exterior of the engine.			
Turbocharger			
Complete the 50-Hour Turbocharger Inspection.	Refer to the "50-Hour Turbocharger Inspection" in Chapter 72-40.		
Ignition System			
Remove spark plug connector nuts and examine spark plug cable leads and ceramics for corrosion and deposits. Replace spark plugs as necessary per Chapter 74-20. Clean the cable ends, spark plug walls, and ceramics.	Corrosion and deposits are evidence of leaking spark plugs or of improper cleaning of the spark plug walls or connector ends. Refer to the section "Spark Plug Cleaning" in Chapter 05-30.		
Make sure that the spark plug connections are tight.			
Replace any broken, cracked, deformed, or corroded parts.			
Dry all parts using compressed air.			
Examine each ignition lead for chafing, insulation breakdown, frayed wiring, deterioration, heat damage, wear, and cracking. Examine the ignition lead routing.	Refer to the section "Ignition Lead Inspection" in Chapter 74-20.		
Make sure that the ignition lead mounting clamps are tight.	Tighten any loose clamps.		

50-Hour Engine Inspection Checklist for TEO-540-A1A Engines (Cont.)							
Inspection Item	Comments			Results/Notes			Done
Fuel System							
Complete the "Fuel System Inspection" and checklist in Chapter 73-10.							
Induction System							
Complete the Induction System Inspection.	Refer to the "Induction System Inspection" procedure in Chapter 72-80.						
Engine Cylinders							
Examine the rocker box covers for oil leaks. Identify and correct the cause of oil leaks (Chapter 72-30). For possible causes and corrections, refer to the section "Fault Isolation Guide" in Chapter 12-30.	Cyl. 1	Cyl. 2	Cyl. 3	Cyl. 4	Cyl. 5	Cyl. 6	
Alternators							
Make sure the alternator belt support bracket and mountings are tight.	Tighten all loose hardware per torque values in the Standard Torque Tables in the latest revision of the <i>Service Table of Limits - SSP-1776</i> .						
Exhaust System							
Examine the exhaust system.	Complete the section "50-Hour Exhaust System Inspection" in Chapter 78-00.						
Operational Test							
Complete the Operational Ground Check in Chapter 72-00.							

6. 100-Hour or Annual Engine Inspection for TEO-540-A1A Engines


NOTICE: Refer to the aircraft manufacturer’s recommendation as to whether this inspection is to be completed every 100 hours of engine operation or annually.

- A. The purpose of this inspection is to examine the ignition, electrical systems, the engine cylinders, the turbocharger, fuel system, and the exhaust system.
- B. Complete the 100-Hour Engine Inspection after the first 100 hours of operation since the engine has been in service and then after every 100 hours of operation or during each annual aircraft inspection (whichever occurs first).
- C. Copy and complete the 100-hour or Annual Engine Inspection Checklist for TEO-540-A1A engines as a record of engine service. Record the engine hours.

⚠ WARNING BEFORE ANY ENGINE INSPECTION OR SERVICE PROCEDURE, MAKE SURE THE IGNITION SWITCH IS SET TO OFF AND THAT ALL POWER TO THE ENGINE IS DISCONNECTED. ENSURE ALL OBJECTS/PERSONNEL ARE CLEAR OF THE PROPELLER’S ROTATIONAL ARC. IF POWER IS ON, A LOOSE OR BROKEN WIRE CAN CAUSE THE ENGINE TO START AND THE PROPELLER TO TURN WHICH CAN LEAD TO A PROPELLER STRIKE, SERIOUS INJURY, OR DEATH.

100-Hour or Annual Engine Inspection Checklist for TEO-540-A1A Engines			
Engine Serial Number: _____		Engine Time: _____	
Date Inspection Done: _____		Inspection done by: _____	
NOTICE: Complete the Operational Ground Check prior to and after each inspection, and after maintenance. Refer to Chapter 72-00.			
Inspection Item	Comments	Results/Notes	Done
Complete the 50-Hour Engine Inspection Checklist.	Refer to the section “50-Hour Engine Inspection for TEO-540-A1A Engines” in this chapter.		
Turbocharger			
Complete the 100-Hour Turbocharger Inspection	Refer to the “100-Hour Turbocharger Inspection” section in Chapter 72-40 of this manual.		
Exhaust System			
Complete 100-Hour Exhaust System Inspection	Refer to the section "100-Hour Exhaust System Inspection Procedure" in Chapter 78-00.		

100-Hour or Annual Engine Inspection Checklist for TEO-540-A1A Engines (Cont.)			
Inspection Item	Comments	Results/Notes	Done
Fuel System			
Complete the Fuel System Inspection.	Refer to the section "Fuel System Inspection" procedure in Chapter 73-10.		
<p>⚠ CAUTION DO NOT ATTEMPT TO REPAIR A DAMAGED FUEL HOSE. REPLACE ANY FUEL HOSE THAT IS CRACKED OR KINKED; CRACKS CAN DEVELOP AT THE SIDE OF SHARP BENDS OR KINKS.</p>			
Examine the fuel injector rail assembly for damage, leaks, and loose fittings or connections. Tighten any loose fitting or connection per the Standard Torque Tables in the latest revision of the <i>Service Table of Limits - SSP-1776</i> .	Replace a damaged fuel injector rail assembly per the "Fuel Injector Rail Assembly Replacement" procedure in this chapter.		
Make sure fuel hoses are held securely in place using clamps with cushions.	<p>If no clamps are attached to the fuel hose that was in service, replace the fuel hose per instructions in Chapter 73-10.</p> <p>If cushions on clamps are deteriorated or missing, replace the clamps and fuel hose.</p> <p>If the clamps are loose, replace the fuel hose.</p> <p>NOTICE: Plastic tie straps are not an acceptable substitute for clamps.</p>		
Examine the fuel injectors for leaks and correct installation.	Refer to the section "Fuel Injector Leak Check" in Chapter 73-10.		
Examine the flexible fuel hoses.	Replace any fuel hoses that have become hard. Refer to the "Fuel Hose Replacement" procedure in Chapter 73-10.		
Examine gaskets, and seals for deterioration or leakage.	Replace any gaskets, or seals that are worn, damaged, or leaking.		

100-Hour or Annual Engine Inspection Checklist for TEO-540-A1A Engines (Cont.)			
Inspection Item	Comments	Results/Notes	Done
Ignition System			
 CAUTION NEVER INSTALL A SPARK PLUG THAT HAS BEEN DROPPED ON THE FLOOR.			
Remove, examine, rotate, clean, and re-gap acceptable spark plugs.	Replace worn spark plugs. Refer to Chapter 74-20.		
Examine each ignition lead for chafing, insulation breakdown, frayed wiring, deterioration, heat damage, wear, and cracking.	Refer to the section "Ignition Lead Inspection" in Chapter 74-20.		
Examine the engine ground straps for damage and security.	Refer to the aircraft manufacturer's instructions.		
Power			
Examine the power box for physical damage. Make sure it is securely attached.	Replace a damaged power box. Refer to the section "Power Box Removal" and "Power Box Installation" in Chapter 72-70.		
Examine the alternator belt(s).	Refer to the section "Alternator Belt Inspection" in Chapter 72-70.		
Complete a check of the alternator belt tension.	Refer to the section "Alternator Belt Tension Check/Adjustment" in Chapter 72-70.		
Examine the alternator attaching hardware for damage. Make sure that safety wire/cable and cotter pins are installed and tight.			
Electrical System			
Complete the Wiring Inspection.	Refer to the section "Wiring Inspection" in Chapter 72-70.		
Examine engine controls for security, safety, locking devices, and full range of travel.			

100-Hour or Annual Engine Inspection Checklist for TEO-540-A1A Engines (Cont.)			
Inspection Item	Comments	Results/Notes	Done
Engine Controls			
Examine the knock, temperature, and pressure sensors for security and damage.	If a damaged sensor is found, replace the sensor. Refer to the section "Sensor Replacement Procedures" in Chapter 72-70.		
Look at ECU Fault Codes and investigate Fault Code cause.	Refer to the Troubleshooting Guide in Appendix D of this manual to identify the fault and complete the Troubleshooting Steps.		
Crankcase			
Complete the crankcase inspection.	Refer to the "Exterior Crankcase Inspection" procedure in Chapter 72-20.		
Engine Accessories			
Complete the accessory drive inspection.	Refer to the "Accessory Drive Inspection" procedure in Chapter 72-60.		
Engine Mounts			
Complete the engine mount inspection.	Refer to the "Engine Mount Inspection" procedure in Chapter 72-00.		
Cylinders			
Complete the "Visual Cylinder Inspection" procedure in Chapter 72-30. Record the results for each cylinder.			
Inspection Item	Results/Notes		Done
Cylinder 1			
Cylinder 2			
Cylinder 3			
Cylinder 4			
Cylinder 5			
Cylinder 6			

100-Hour or Annual Engine Inspection Checklist for TEO-540-A1A Engines (Cont.)		
Inspection Item	Results/Notes	Done
Cylinder Compression Check		
Complete the “Cylinder Compression Check Procedure” in Chapter 72-30. Record the results for each cylinder.		
Cylinder 1		
Cylinder 2		
Cylinder 3		
Cylinder 4		
Cylinder 5		
Cylinder 6		
Operational Test		
Complete an Operational Ground Check in Chapter 72-00.		

7. 250-Hour Engine Inspection for TEO-540-A1A Engines
 - A. Complete the 250-Hour Engine Inspection after every 250 hours of operation since the engine has been in service.
 - B. The purpose of this inspection is to examine the exhaust system and turbocharger.
 - C. Copy and complete the 250-Hour Engine Inspection Checklist for TEO-540-A1A engines as a record of engine service. Record the engine hours.
 - D. Correct any discrepancies found before returning the engine to service.

⚠ WARNING BEFORE ANY ENGINE INSPECTION OR SERVICE PROCEDURE, MAKE SURE THE IGNITION SWITCH IS SET TO OFF AND THAT ALL POWER TO THE ENGINE IS DISCONNECTED. ENSURE ALL OBJECTS/PERSONNEL ARE CLEAR OF THE PROPELLER’S ROTATIONAL ARC. IF POWER IS ON, A LOOSE OR BROKEN WIRE CAN CAUSE THE ENGINE TO START AND THE PROPELLER TO TURN WHICH CAN LEAD TO A PROPELLER STRIKE, SERIOUS INJURY, OR DEATH.

250-Hour Engine Inspection Checklist for TEO-540-A1A Engines			
Engine Serial Number: _____		Engine Time: _____	
Date Inspection Done: _____		Inspection done by: _____	
Inspection Item	Comments	Results/Notes	Done
Complete the 100-Hour or Annual Engine Inspection Checklist.	Refer to the section “100-Hour or Annual Engine Inspection for TEO-540-A1A Engines” in this chapter.		
Exhaust System			
Complete the 250-Hour Exhaust System Inspection	Refer to the “250-Hour Exhaust System Inspection Procedure” in Chapter 78-00 of this manual.		
Turbocharger			
Complete the 250-Hour Turbocharger Inspection	Refer to the “250-Hour Turbocharger Inspection” in Chapter 72-40 of this manual.		
Replace the Turbine Inlet Temperature Sensor.	Refer to Table 3 “Sensor Replacement Procedures” in Chapter 72-70 of this manual.		

8. 400-Hour Engine Inspection for TEO-540-A1A Engine Models
 - A. Complete the 400-Hour Engine Inspection after every 400 hours of operation since the engine has been in service.
 - B. The purpose of this inspection is to examine the engine cylinders and to complete a cylinder borescope inspection on each cylinder.
 - C. Copy and complete the 400-Hour Engine Inspection Checklist for TEO-540-A1A Engines as a record of engine service. Record the engine hours.

⚠ WARNING BEFORE ANY ENGINE INSPECTION OR SERVICE PROCEDURE, MAKE SURE THE IGNITION SWITCH IS SET TO OFF AND THAT ALL POWER TO THE ENGINE IS DISCONNECTED. ENSURE ALL OBJECTS/PERSONNEL ARE CLEAR OF THE PROPELLER’S ROTATIONAL ARC. IF POWER IS ON, A LOOSE OR BROKEN WIRE CAN CAUSE THE ENGINE TO START AND THE PROPELLER TO TURN WHICH CAN LEAD TO A PROPELLER STRIKE, SERIOUS INJURY, OR DEATH.

400-Hour Engine Inspection Checklist for TEO-540-A1A Engines			
Engine Serial Number: _____		Engine Time: _____	
Date Inspection Done: _____		Inspection done by: _____	
Inspection Item	Comments	Results/Notes	Done
Complete the 100-Hour or Annual Engine Inspection Checklist.	Refer to the section “100-Hour or Annual Engine Inspection for TEO-540-A1A Engines” in this chapter.		
Cylinders			
Remove the rocker box covers from all of the engine cylinders. Look for evidence of wear or broken parts in the area of the valve tips, valve keeper, springs, and spring seats. If any of these conditions are found, remove the cylinder and piston and examine for further damage.	Refer to the “Cylinder Removal” procedure in Chapter 72-30.		
General			
Check for Fault Codes	Refer to the Troubleshooting Guide in Appendix D of this manual to identify the fault and complete the Troubleshooting Steps.		



400-Hour Engine Inspection Checklist for TEO-540-A1A Engines (Cont.)			
Complete the “Cylinder Borescope Inspection” procedure in Chapter 72-30. Record the results below for each engine cylinder.			
Cylinder 1			
Cylinder 2			
Cylinder 3			
Cylinder 4			
Cylinder 5			
Cylinder 6			
Inspection Item	Comments	Results/Notes	Done
Operational Test			
Complete an Operational Ground Check in Chapter 72-00.			

9. 1000-Hour Engine Inspection for TEO-540-A1A Engine Models
 - A. Complete the 1000-Hour Engine Inspection after every 1000 hours of operation since the engine has been in service.
 - B. The purpose of this inspection is to examine the exhaust valves and guides on the engine cylinders.

NOTICE: If valve sticking is a problem, this inspection must be done. Refer to the section “Corrective Action for Valve Sticking” in Chapter 72-30.

If this 1000-hour inspection is completed prior to the scheduled 1000-hour inspection it must be completed 1000 hours from the time of inspection.

- C. Copy and complete the 1000-Hour Engine Inspection Checklist for TEO-540-A1A engine models as a record of engine service. Record the engine hours.

⚠ WARNING BEFORE ANY ENGINE INSPECTION OR SERVICE PROCEDURE, MAKE SURE THE IGNITION SWITCH IS SET TO OFF AND THAT ALL POWER TO THE ENGINE IS DISCONNECTED. ENSURE ALL OBJECTS/PERSONNEL ARE CLEAR OF THE PROPELLER’S ROTATIONAL ARC. IF POWER IS ON, A LOOSE OR BROKEN WIRE CAN CAUSE THE ENGINE TO START AND THE PROPELLER TO TURN WHICH CAN LEAD TO A PROPELLER STRIKE, SERIOUS INJURY, OR DEATH.

1000-Hour Engine Inspection Checklist for TEO-540-A1A Engine Models			
Engine Serial Number: _____		Engine Time: _____	
Date Inspection Done: _____		Inspection done by: _____	
NOTICE: Complete the Operational Ground Check prior to and after each inspection, and maintenance. Refer to Chapter 72-00.			
Inspection Item	Comments	Results/Notes	Done
Complete the Visual Inspection Checklist in this chapter.	Refer to the section “Visual Inspection for TEO-540-A1A Engines” in this chapter.		
Complete the “Exhaust Valve and Guide Inspection” procedure in Chapter 72-30. Record the results for each cylinder below.			
Exhaust Valve and Guide Inspection			
Cylinder 1			
Cylinder 2			
Cylinder 3			

1000-Hour Engine Inspection Checklist for TEO-540-A1A Engine Models (Cont.)			
Exhaust Valve and Guide Inspection (Cont.)			
Cylinder 4			
Cylinder 5			
Cylinder 6			
Inspection Item	Comments	Results/Notes	Done
Operational Test			
Complete an Operational Ground Check in Chapter 72-00.			
General			
Check for Fault Codes	Refer to the Troubleshooting Guide in Appendix D of this manual to identify the fault and complete the Troubleshooting Steps.		

This page intentionally left blank.

05-30 - CLEANING

1. Cleaning Guidelines

NOTICE: The goal to keep the engine and nacelle clean is to prevent contamination from foreign object debris (FOD) which can adversely affect engine operation.

A. Refer to Table 1 for cleaning guidelines for engine components.

⚠ CAUTION IF VOLCANIC ASH IS SUSPECTED ON THE ENGINE, DO NOT INHALE IT OR TOUCH IT WITH BARE HANDS OR GET IT IN YOUR EYES. WEAR PERSONAL PROTECTIVE EQUIPMENT. DO NOT USE WATER TO RINSE IT OFF. THE VOLCANIC ASH CAN CONTAIN ACIDIC COMPOUNDS WHICH MUST NOT BE INHALED OR TOUCHED SINCE IT CAN CAUSE INJURY. REFER TO THE SECTION "VOLCANIC ASH REMOVAL" IN THIS CHAPTER.

NOTICE: Except for parts contaminated with suspect volcanic ash, before cleaning engine parts, complete a visual inspection (per Chapter 05-20) of engine parts to identify any stains and residues and sources thereof.

B. After the initial visual inspection (in Chapter 05-20), clean engine parts thoroughly per instructions in this chapter.

⚠ CAUTION DO NOT USE ALKALINE (CAUSTIC) CLEANING SOLUTIONS SUCH AS DETERGENTS ON ENGINE PARTS. ALKALINE SOLUTIONS REMOVE THE FINISH ON ALUMINUM PARTS AND MAGNESIUM PARTS.
ALKALINE COMPOUNDS CAN GET INTO THE PORES OF THE METAL WHICH CAN CAUSE OIL FOAMING WHEN THE PART IS PUT BACK INTO SERVICE.
OBEY STANDARD SAFETY PRACTICES REGARDING THE HANDLING OF CLEANING MATERIALS AND THE USE OF PERSONAL PROTECTIVE EQUIPMENT.

NOTICE: If you are not sure of the correct cleaning agent or whether the component contains aluminum or magnesium, contact Lycoming Engines Technical Support at the phone numbers in the front of the manual.

C. There are two processes for cleaning: degreasing and decarbonizing.

(1) Degreasing removes dirt and sludge (soft carbon). Soak the component or part in mineral spirits or other degreaser. Refer to the "Soft Carbon Removal" procedure in this chapter.

⚠ CAUTION DO NOT USE ANY HEATED DECARBONIZING SOLVENT ON ALUMINUM OR MAGNESIUM PARTS. THE DECARBONIZING SOLVENT CAN DAMAGE OR CORRODE MAGNESIUM AND ALUMINUM PARTS.

(2) Decarbonizing removes hard carbon with an initial soak of the part in a warm or heated decarbonizing solution. After the soak, use a (non-wire) bristle brush, wooden scraper, or grit-blasting (with non-abrasive media as per the "Grit-Blast Procedure" in this chapter) to physically remove the hard carbon. Refer to the "Hard Carbon Removal" procedure in this chapter.

NOTICE: Since decarbonizing can remove most of the enamel from exterior surfaces, remove any remaining enamel by grit-blasting.

Table 1
Cleaning Guidelines for Engine Components

Component or Part	Cleaning Agent*	Guidelines
Crankshaft	Mineral spirits, MIL-PRF-680 or equivalent	Refer to the “Crankshaft Cleaning” procedure in this chapter
Crankshaft Counterbore	Mineral spirits, MIL-PRF-680 or equivalent or Stoddard Solvent or equivalent	Refer to the “Crankshaft Counterbore Cleaning” procedure in this chapter
Crankshaft Trigger Gear Assembly	Mineral spirits, MIL-PRF-680 or equivalent or Stoddard Solvent or equivalent	Refer to the “Crankshaft Trigger Gear Assembly Cleaning” procedure in this chapter.
Camshaft	Mineral spirits, MIL-PRF-680 or equivalent	
Tappets	Petroleum-based solvent	Refer to the “Tappet Cleaning” procedure in this chapter.
Crankcase	Petroleum-based solvent	Refer to the “Crankcase Cleaning” procedure in this chapter.
Removal of silk thread and/or gasket material from crankcase mating flanges	Methyl-Ethyl-Ketone (MEK) Acetone Napsco SC-200 M-17 M-114	
Removal of gasket material on vacuum pump housing or other surfaces	MEK Acetone Naphtha or equivalent	Apply solvent to gasket material Use a wooden, plastic, or phenolic scraper to remove gasket material. Wipe away all debris with a clean lint-free wipe.
Accessory Housing		Refer to the “Soft Carbon Removal” procedure in this chapter
Cylinders	Mineral spirits (MIL-PRF-680), kerosene or equivalent degreasing solvent	Refer to the “Cylinder Cleaning” procedure in this chapter.
Deposits in cylinder combustion chamber		Refer to the “Grit-Blasting the Combustion Chamber in an Engine Cylinder” procedure in this chapter.
Connecting Rods	Mineral spirits, MIL-PRF-680 or equivalent	
Interior surfaces of aluminum parts with hard carbon or oil varnish (gum) deposits	Petroleum-based decarbonizing solutions (Gunk [®] , Penetrol [®] , or equivalent)	Refer to the “Hard Carbon Removal” procedure in this chapter.

**Table 1 (Cont.)
Cleaning Guidelines for Engine Components**

Component or Part	Cleaning Agent*	Guidelines
Valve rockers	Mineral spirits (MIL-PRF-680), kerosene or equivalent degreasing agent	Clean with Scotch-Brite™ or equivalent. Remove debris with clean lint-free wipes.
Stabilizers, valve components, starter drive, fuel control inlet screen	Mineral spirits (MIL-PRF-680), kerosene or equivalent degreasing agent	
Piston	Mineral spirits (MIL-PRF-680), Safety Solvent or equivalent degreasing solvent	Refer to the “Piston Cleaning” procedure in this chapter.
Small steel parts	Mineral Spirits Cold Dip Tanks (or closed tank system) and use NALCO 1704	Refer to the “Steel, Aluminum or Magnesium Parts Cleaning” procedure in this chapter.
Large steel parts covered with light oil	Oil-based solvent: mineral spirits or equivalent	Refer to the “Steel, Aluminum or Magnesium Parts Cleaning” procedure in this chapter.
Aluminum or magnesium parts		Refer to the “Steel, Aluminum or Magnesium Parts Cleaning” procedure in this chapter.
Oil sump Oil pump and oil pump housing	Mineral spirits, MIL-PRF-680 or equivalent	
Oil suction screen	Mineral spirits, MIL-PRF-680 or equivalent degreasing solvent	Refer to Chapter 12-10 for additional details.
Oil cooler bypass valve	Mineral spirits, MIL-PRF-680 or equivalent degreasing solvent	<p align="center">⚠ CAUTION</p> <p align="center">DO NOT USE RAGS OR ANY LINT CLOTH TO CLEAN THIS VALVE.</p> <p>Soak the oil cooler bypass valve in filtered mineral spirits.</p>
Spark plugs	Commercially available spark plug cleaner.	Refer to the spark plug manufacturer’s cleaning instructions, regap spark plugs after cleaning
Spark plug lead connector, cable ends, and ceramics	MEK Acetone Wood Alcohol Naphtha or equivalent	Refer to the “Spark Plug Cleaning” procedure in this chapter.
Lead deposits		Refer to the “Lead Deposit Removal” procedure in this chapter.

**Table 1 (Cont.)
Cleaning Guidelines for Engine Components**

Component or Part	Cleaning Agent*	Guidelines
Fuel pump filter	MEK Acetone	(1) Clean in an ultrasonic cleaner. (2) Blow dry with compressed air.
Electrical connectors	CR4 or equivalent	Refer to contact cleaning solvent manufacturer's instructions.
Turbocharger		Refer to the turbocharger manufacturer's instructions.
Final spot cleaning/touch-up cleaning	Parts washer solvent Naptha spray booth	
Hartzell Engine Technologies (HET) (formerly Kelly Aerospace) starter		Refer to the starter manufacturer's cleaning instructions.
All other parts	Parts washer solvent using Whirlwash-L or equivalent	
Volcanic ash on engine		Refer to the "Volcanic Ash Removal" procedure in this chapter.
Engine exterior and components not contaminated with volcanic ash		Use a brush or spray to apply degreaser (hydrocarbon-based solvent) to parts to remove grease, oil, and dirt
*Refer to the manufacturer's instructions for usage, safety data, and disposal of all cleaning agents.		

2. Crankshaft Cleaning

⚠ CAUTION DO NOT MAKE SCORES, SCRATCHES, OR ETCH MARKINGS OF ANY KIND ON THE CRANKSHAFT SINCE THEY CAN CAUSE THE PART TO WEAKEN AND TO FAIL.
DO NOT USE WIRE BRUSHES OR METAL SCRAPERS ON BEARINGS OR CONTACT SURFACES.

- A. Clean the inside of all crank pin journals, main bearing journals, and all oil passages with bristle (non-wire) brushes.
- B. Clean all parts thoroughly with mineral spirits (MIL-PRF-680) or equivalent.
- C. Dry the crankshaft with compressed air.
- D. Apply preservative oil to the crankshaft to prevent corrosion.

3. Crankshaft Counterbore Cleaning

- A. Flush the crankshaft counterbore and alignment dowel pin with mineral spirits (MIL-PRF-680) or equivalent or Stoddard Solvent or equivalent solvent to remove any debris.
- B. Dry the crankshaft counterbore threads with compressed air.

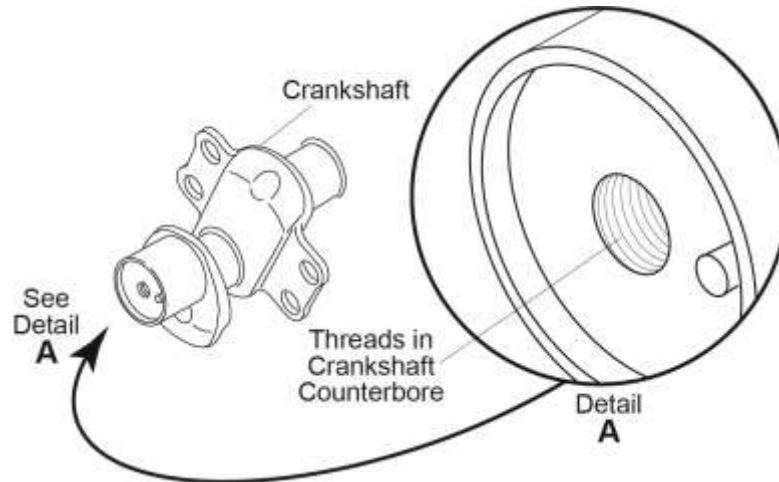


Figure 1
Threads in the Crankshaft Counterbore

C. Clean the threads in the crankshaft counterbore (Figure 1) as follows:

- (1) Use the correct sized undamaged bottoming tap for a 5/16-24 thread size. Do not use an oversized tap.

⚠ CAUTION TO PREVENT MAKING THE THREADS IN THE CRANKSHAFT COUNTERBORE TOO LARGE, USE THE CORRECTLY SIZED TAP. IF THE INCORRECT TAP IS USED, THE BORE CAN BE MADE TOO LARGE TO CORRECTLY ENGAGE THE THREADS ON THE CRANKSHAFT GEAR BOLT WHEN THE CRANKSHAFT GEAR IS INSTALLED ON THE CRANKSHAFT. IF THE BOLT THREADS ARE TOO LARGE, DISCARD THE CRANKSHAFT AND REPLACE IT WITH A NEW CRANKSHAFT.

- (2) Install the tap into the recessed counterbore on the crankshaft.
- (3) Turn the tap as necessary to clean the threads.
- (4) Remove the tap.
- (5) Flush the crankshaft counterbore threads with mineral spirits (MIL-PRF-680) or equivalent or Stoddard Solvent, or equivalent solvent to remove any debris.
- (6) Dry the crankshaft counterbore threads with compressed air.

D. Examine the threads in the crankshaft counterbore (Figure 1). If the threads are worn, stripped, galled, or damaged, send the crankshaft to Lycoming Engines for repair.

4. Crankshaft Trigger Gear Assembly Cleaning

- A. Soak the crankshaft trigger gear assembly in mineral spirits (MIL-PRF-680) or equivalent or Stoddard Solvent, or equivalent solvent.
- B. Remove all dirt and debris from the crankshaft trigger gear assembly with a lint-free wipe.
- C. Dry with compressed air.
- D. Complete the “Crankshaft Counterbore Cleaning” procedure in this chapter.

5. Tappet Cleaning

- A. Clean the tappets using the cleaning procedure in the next steps. Refer to the latest revision of Service Instructions SI-1011 and SI-1514 for details about tappets.

NOTICE: During disassembly and cleaning, keep the tappet parts together.

- B. Put tappets in a special cleaning basket that has separate compartments to keep the parts for each tappet as a set, identified but segregated from other tappets.
- C. Put the cleaning basket with the tappets immersed in a petroleum-based solvent.
- D. Flush with petroleum-based solvent and blow dry with compressed air.

NOTICE: If the cleaned tappets are acceptable per the “Tappet Inspection” in Chapter 72-20, they can be re-installed.

- E. Apply a light coat of engine oil to the lifter parts before tappet assembly.

6. Crankcase Cleaning

- A. Grit-blast the crankcase (as necessary) to remove all coatings on the crankcase and engine mount bosses. Refer to the sections “Grit-Blasting,” “Grit-Blast Media,” and “Grit Blast Procedure” in this chapter. Make sure there is no dirt, debris, sludge, paint, or any other substance that could prevent reliable fluorescent penetrant inspection (FPI) or subsequent oil flow.

- B. Remove all plugs from oil passages in the crankcase.

NOTICE: Clean the crankcase after all grit-blasting is complete.

- C. Use a stiff bristle fiber (not wire) brush and clean petroleum solvent to clean and flush the oil passages.
- D. Use compressed air to clean and dry the oil passages.
- E. Prior to installation of a new crankshaft oil seal, clean the crankcase bore, use a clean disposable lint-free cloth and any of the following cleaning solvents to remove oil, sealant, and debris from the crankcase, especially the crankcase bore which has the groove for the crankshaft oil seal:

- Methyl-Ethyl-Ketone (MEK)
- Acetone
- Napasco SC-200
- M-17
- M-114.

⚠ CAUTION ONLY APPLY MEK TO THE CRANKCASE, INCLUDING THE CRANKCASE BORE AND GROOVE FOR THE CRANKSHAFT OIL SEAL. DO NOT APPLY MEK SOLVENT TO THE CRANKSHAFT OIL SEAL SINCE MEK CAN CAUSE THE SEAL TO DETERIORATE. BE SURE TO REMOVE ALL TRACES OF MEK OR CLEANING SOLVENT, OIL AND SEALANT PRIOR TO INSTALLATION OF A NEW CRANKSHAFT OIL SEAL.

7. Grit-Blasting

Do not grit-blast the following:

- Piston ring grooves and piston skirts
- Valve stems
- Valve guides
- Bearing surfaces
- Bushings
- Gears
- Any machined surface


A. Grit-Blast Media

 **CAUTION** DO NOT USE SAND OR METALLICALLY ABRASIVE MATERIALS TO GRIT-BLAST.

During grit-blasting for general cleaning of components not subject to Non-Destructive Testing (NDT), only use mildly abrasive blast media such as 17-grit walnut shells or equivalent.

For components subject to NDT, do not use 17-grit walnut shells, use a fine abrasive of 150-grit or finer. Refer to the "Cleaning Methods for Non-Destructive Testing" section in this chapter.

B. Grit-Blast Procedure

 **CAUTION** ALWAYS REMOVE ANY COMPONENT OR PART FROM THE ENGINE BEFORE GRIT-BLASTING THE COMPONENT OR PART.
MASK OR PROTECT ALL MACHINED SURFACES, BEARING SURFACES, BUSHINGS, AND GEARS ON COMPONENTS OR ENGINE PARTS DURING GRIT-BLASTING.

- (1) To grit-blast the engine cylinders, refer to the section "Grit-Blasting the Combustion Chamber in an Engine Cylinder" in this chapter.
- (2) Hold the grit-blast gun (filled with the correct grit-blast media), a few inches away, but pointed toward the surface to be grit-blasted. Operate the grit-blast gun as per the manufacturer's instructions.
- (3) Unless otherwise specified in the manufacturer's instructions, use approximately 35 to 45 psi (241 to 310 kPa) of air pressure during grit-blasting.
- (4) Use compressed air and the vacuum cleaner to remove any debris and residue.
- (5) After all cleaning is complete:
 - (a) Rinse the part in a petroleum solvent.
 - (b) Dry the part with an air blast to remove all loose particles.
 - (c) Apply a coating of preservative oil to the entire part.
 - (d) Put cleaned oil and fuel system components in a clean sealed container until ready for assembly.
 - (e) Install clean plastic caps or covers over each open end of a cleaned hollow tube, hose or line to prevent debris from entering these areas.
 - (f) Put remaining cleaned parts on clean bench surfaces where there is no particulate, dirt, grit, or other unwanted materials.

8. Soft Carbon Removal

- A. Unless otherwise directed, put the component in a bath tank fully immersed in mineral spirits or equivalent for 10 minutes.
- B. Remove the component from the bath tank.
- C. Remove any remaining soft carbon (dirt or sludge) from the component with a lint-free wipe.
- D. Apply a spray coating of preservative oil on the component to prevent corrosion.
- E. If the component is not to be installed immediately, put the component in a sealed plastic bag until installation.

9. Hard Carbon Removal

⚠ CAUTION DO NOT PUT STEEL AND MAGNESIUM PARTS INTO THE SAME DECARBONIZING SOLUTION, BECAUSE IT CAN CAUSE CORROSION OF THE MAGNESIUM PARTS.

DO NOT USE ANY HEATED DECARBONIZING SOLVENT ON ALUMINUM OR MAGNESIUM PARTS. THE DECARBONIZING SOLVENT CAN DAMAGE OR CORRODE MAGNESIUM AND ALUMINUM PARTS.

NOTICE: If you are not sure if the component is steel or contains magnesium, contact Technical Support at Lycoming Engines at the phone numbers in the front of the manual.

⚠ CAUTION DO NOT USE WIRE BRUSHES OR METAL SCRAPERS ON BEARINGS OR CONTACT SURFACES.

NOTICE: Hard carbon can remain on interior surfaces of cylinders and combustion chambers after using a degreasing solvent to clean a part.

- A. Put the component with the hard carbon fully immersed into a warm petroleum-based decarbonizing solution (examples: Gunk[®], Penetrol[®], or equivalent) in a heated bath tank or Paint and Ink Remover in an ultrasonic cleaner.
- B. Soak for 10 minutes (to loosen the hard carbon).
- C. Remove the component from the bath tank.
- D. Use a (non-wire) bristle brush, wooden, plastic, or phenolic scraper, or grit-blasting (per the section “Grit-Blasting” in this chapter) to physically remove the hard carbon.
- E. Remove any remaining hard carbon from the component with a lint-free wipe.
- F. Apply a spray coating of preservative oil on the component to prevent corrosion.
- G. If the component is not to be installed immediately, put the component in a sealed plastic bag until installation.

10. Cylinder Cleaning

- A. Clean the internal barrel of the cylinder by flushing it with a hydrocarbon-based solvent (mineral spirits MIL-PRF-680 or equivalent) under air pressure. Use a soft bristle brush in conjunction with flushing to remove abrasive build-up from areas that are otherwise difficult to reach.
- B. Make a hooked tool from soft wire and rub the tool back and forth in the recess to loosen any built-up abrasive. Complete this task each time the cylinder is flushed. There must not be any abraded material in this area.
- C. Remove all oil accumulation from the external sides of the cylinders by washing with mineral spirits (MIL-PRF-680), kerosene, or equivalent degreasing solvent.
- D. Thoroughly dry the cylinder with compressed air.
- E. Clean the cylinder head fin areas thoroughly with mineral spirits (MIL-PRF-680), kerosene or equivalent, to remove all traces of grease, dirt, or other foreign matter, and air dry with compressed air.

F. Grit-Blasting the Combustion Chamber in an Engine Cylinder:

- (1) Remove the intake and exhaust valves from the cylinder to be cleaned. Refer to Chapter 72-30.
- (2) Remove the spark plugs from the cylinder. Refer to the section "Spark Plug Removal" in Chapter 74-20.
- (3) Complete the "Grit-Blast Procedure" in this chapter.
- (4) Record the cleaning for future reference to identify trends and engine operating time for lead build up to occur.
- (5) Wipe the cylinder with a clean, white cloth dipped in SAE 10 engine oil. Examine the cloth under a light for evidence of any abrasive residue remaining in the cylinder. If any residual abrasive is found, repeat the earlier steps in this procedure until there is no abrasive residue.

11. Piston Cleaning

⚠ CAUTION DO NOT USE A STEEL BUFFING BRUSH TO CLEAN THE RING LANDS AND SKIRT OF A PISTON. DO NOT GRIT-BLAST PISTON RING GROOVES OR PISTON SKIRTS. THESE METHODS CAN STRETCH THE SIDES OF THE PISTON RING GROOVES AND ROUND OFF THE OUTER CORNER OF THE PISTON RING LANDS, WHICH AFFECTS THE PISTON CONFIGURATION.

- A. Remove all oil or preservative oil accumulation from the piston by a soak or wash in a clean bath of mineral spirits, Safety Solvent, or equivalent degreasing solvent in compliance with MIL-PRF-680 specifications.
- B. Remove any remaining deposits with a wooden scraper.
- C. Gently clean the piston pin bore with a soft bristle non-metallic brush (Figure 2). Use a gentle twist motion to clean each bore.
- D. After cleaning one side, turn the piston 180° and repeat the previous step to ensure the entire bore is free of FOD.
- E. Soak the piston again in a new clean bath of mineral spirits, Safety Solvent, or equivalent degreasing solvent in compliance with MIL-PRF-680 specifications to remove remaining deposits.
- F. Clean the piston ring grooves thoroughly so there is no debris in the grooves.



Figure 2
Cleaning the Piston Pin Bore with a Soft Bristle Non-Metallic Brush

12. Steel, Aluminum, or Magnesium Parts Cleaning

⚠ CAUTION DO NOT PUT STEEL AND MAGNESIUM PARTS INTO THE SAME DECARBONIZING SOLUTION, BECAUSE IT CAN CAUSE CORROSION OF THE MAGNESIUM PARTS.
DO NOT USE ANY HEATED DECARBONIZING SOLVENT ON ALUMINUM OR MAGNESIUM PARTS. THE DECARBONIZING SOLVENT CAN DAMAGE OR CORRODE MAGNESIUM AND ALUMINUM PARTS.

⚠ CAUTION ONLY USE PETROLEUM-BASED DECARBONIZING SOLUTIONS ON ALUMINUM PARTS.

DO NOT USE CHLORINATED SOLVENTS (SUCH AS TRICHLOROETHANE, TRICHLOROETHYLENE, “PERC”-DEGREASER, ETC), TO PREVENT HYDROGEN EMBRITTLEMENT WHICH CAN WEAKEN A METAL PART AND CAUSE IT TO FAIL.

DO NOT USE WATER-MIXED SOLVENTS THAT CONTAIN CAUSTIC COMPOUNDS AND/OR SOAP, BECAUSE THEY CAN CAUSE DAMAGE TO ALUMINUM AND MAGNESIUM PARTS. WHEN THE ENGINE IS RETURNED TO SERVICE, THESE MATERIALS CAN ENTER THE PORES OF THE METAL AND CAUSE OIL FOAMING.

NOTICE: If you are not sure if the component is steel or contains magnesium or aluminum, contact Technical Support at Lycoming Engines at the phone numbers in the front of this manual.

A. Put the component fully immersed in mineral spirits or equivalent in a bath tank.

NOTICE: For small steel parts, cold dip tanks or a closed tank system can be used with NALCO 1704.

B. Remove the component from the bath tank.

C. Remove any remaining soft carbon (dirt or sludge) from the component with a lint-free wipe.

D. Apply a spray coating of preservative oil on the component to prevent corrosion.

E. If the component is not be installed immediately, put the component in a sealed plastic bag to prevent the oil from drying out.

13. Spark Plug Cleaning

A. Remove the spark plug as per the “Spark Plug Removal” procedure in Chapter 74-20.

B. Refer to the spark plug manufacturer’s cleaning instructions.

C. Clean the ignition lead, cable ends, spark plug walls, and ceramic of the spark plugs (new or reused) as per the spark plug manufacturer’s instructions.

D. Wipe the spark plug lead connector clean using a lint-free cloth moistened with Methyl-Ethyl-Ketone (MEK), acetone, wood alcohol, naphtha, or equivalent.

E. Remove all cleaning residue from the spark plug lead connector.

F. Install the spark plug as per the “Spark Plug Installation” procedure in Chapter 74-20.

14. Lead Deposit Removal

A. Refer to the sections “Grit-Blast Media” and “Grit-Blast Procedure” in this chapter:

(1) If Non-Destructive Testing is not to be done on the component, grit-blast (the component with lead deposits) with 17 grit walnut shells or equivalent at 35 to 45 psi (241 to 310 kPa).

(2) If Non-Destructive Testing is to be done on the component, use a fine abrasive of 150-grit or finer.

B. Remove all debris from the component to prevent problems caused by foreign object debris.

15. Volcanic Ash Removal

⚠ CAUTION IF VOLCANIC ASH IS SUSPECTED ON THE ENGINE, DO NOT INHALE IT OR TOUCH IT WITH BARE HANDS OR GET IT IN YOUR EYES. WEAR PERSONAL PROTECTIVE EQUIPMENT. DO NOT USE WATER TO RINSE IT OFF. THE VOLCANIC ASH CAN CONTAIN ACIDIC COMPOUNDS WHICH MUST NOT BE INHALED OR TOUCHED SINCE IT CAN CAUSE INJURY.

- A. Engine exterior and components NOT contaminated with volcanic ash:
 - (1) Remove grease, oil, dirt, and soft carbon deposits from the parts.
 - (2) Spray or brush the components with a hydrocarbon-base solvent.
- B. To remove volcanic ash:
 - (1) Wear personal protective equipment (gloves, respiratory, and eye protection).
 - (2) Per the aircraft manufacturer's instructions, thoroughly remove the ash or particulate from the aircraft by hand brushing or air/vacuuming. Make sure that all ash is removed from the engine and cowling.
- C. Examine the induction filters, induction system, and engine baffles for blockage or damage.
- D. Refer to the section "Volcanic Ash/Particulate Contamination" in Chapter 05-50 for further details.
- E. Refer to the aircraft manufacturer's instructions for additional information

16. Cleaning Guidelines for a Soaked Engine

- A. Clean the engine, especially all recessed areas where debris and silt can get trapped.
- B. When cleaning parts removed from an engine that was soaked, especially ferrous (iron) metals, do not use hot acidic cleaning agents or electrolytic cleaning methods (such as cathodic cleaning) since they can cause hydrogen embrittlement. This embrittlement can cause a metallic part to weaken and fail.
- C. Additionally, acids can generally attack the metals and cause pitting or other corrosion damage.
- D. Be sure to remove all cleaning agents.
- E. Rinse the part thoroughly.
- F. Dry the part.
- G. There must not be any cleaning agent residue on the metal surfaces. Any chemical that could either corrode the metal or create hydrogen gas which can cause hydrogen embrittlement during service.
- H. Paint strippers are usually organic solvents like MEK or acetone or toluene, etc. and typically will not cause any damage to metals. Except for chlorinated solvents (such as trichloroethane, trichloroethylene, "perc"-degreaser, etc.), just about any other type of solvent can be used on steel or aluminum parts. Chlorinated solvents can react with moisture and produce some hydrochloric acid which could harm the metal.

17. Cleaning Method for Non-Destructive Testing

A. Remove all traces of:

- Paint
- Gasket materials
- Oil
- Grease
- Dirt
- Corrosion
- Smearred metal
- Plating
- Chemical residues

B. Use any of the following cleaning methods as long as it is not harmful to the component or its intended function:

- Vapor degreasing
- Solvent degreasing
- Ultrasonic cleaning
- Chemical cleaning
- Aqueous-based cleaning
- Mechanical cleaning (such as grit-blasting)

NOTICE: Grit blasting without etching can be an acceptable cleaning method if it can be demonstrated that a sufficiently fine abrasive (150 grit or finer) will not cause peening and can be removed by a detergent or alkaline cleaner.

Etching of the area(s) to be examined is to be done prior to inspection when evidence exists that previous cleaning, surface treatments, or service usage has produced a surface condition that degrades the effectiveness of the penetrant examination.

05-50 - UNSCHEDULED CORRECTIVE MAINTENANCE

1. Unscheduled corrective maintenance is necessary when any of the following conditions occur:

A. Lightning Strike	F. Engine on Fire or	J. Oil Starvation/Sudden Loss of Oil Pressure
B. Engine Overspeed	Near Fire	K. Metal Contamination of the Lubrication System
C. Engine Overboost	G. Hydraulic Lock	L. NTO & TLO Illumination on the Control Panel
D. Incorrect Fuel or Fuel Contamination	H. Volcanic Ash/Particulate Contamination	M. Propeller Strike, Sudden Engine Stoppage, or Loss of Propeller Blade Tip
E. Soaked Engine	I. Valve Sticking	

A. Lightning Strike - After a lightning strike:

After a lightning strike, if there is external evidence of electrical damage to the engine or propeller or evidence of magnetism of the engine or propeller, before the next flight, complete a visual inspection of the engine and propeller for electrical arc damage (in accordance with the airframe and propeller manufacturer's recommended procedures/guidance).

If there is evidence of arc damage, send the engine either to Lycoming Engines or an FAA authorized repair facility for an internal inspection and evaluation on whether an engine repair or overhaul is necessary.

OR

Complete the following in the field in accordance with the applicable Lycoming Engines' manual:

- (1) Remove, disassemble, and clean the engine (per Chapters 72-00, 72-05, 72-20, and 05-30).
- (2) Examine the engine compartment in the aircraft, the engine, external surfaces, internal parts for discoloration, cracks, and other indications of arcing and heat damage.

NOTICE: Refer to the latest revision of Service Bulletin No. 240 which identifies certain parts that must be replaced on engine reassembly. **Do not re-install any part if it is discolored, cracked, or damaged. Replace the part with a serviceable part.**

- (3) Visually examine all wiring and electrical components for:
 - (a) Heat damage to the harness braiding and on the engine in galleys and behind panel lights
 - (b) Burnt wire, cracked insulation, evidence of arcing
 - (c) Evidence of arcing or heat damage to the harness connector and airframe receptacles for the aircraft interface
 - (d) Evidence of arcing or heat damage to the engine harness ground terminals
- (4) Review the fault codes recorded after the lightning strike for an indication of sensors affected by the lightning strike.
- (5) Replace all affected wiring, sensors, and electrical components.
- (6) Assemble the engine and complete an Operational Ground Check, per the applicable Lycoming manual or the aircraft manufacturer's Pilot's Operating Handbook (POH), to ensure the engine is operating correctly.

B. Engine Overspeed

⚠ CAUTION DO NOT OPERATE THE ENGINE CONTINUOUSLY AT AN OVERSPEED RATE BECAUSE PARTS CAN WEAR OUT AND EVENTUALLY CAUSE ENGINE FAILURE.

- (1) In *engine overspeed*, the engine operates above its rated (speed) revolutions per minute (rpm). *Momentary overspeed* is an increase of no more than 10% of rated engine rpm for a period not exceeding 3 seconds. If the duration and amount of overspeed is calculated to fall within the limitations defined as momentary, no further maintenance actions are necessary.

NOTICE: The EECS controls engine operation to prevent overspeed. Refer to the engine specifications in Appendix A of the *TEO-540-A1A Engine Installation and Operation Manual* for rated engine speed.

Record all incidents of engine overspeed in the engine logbook along with any corrective action identified herein.

- (2) If an engine is operated at overspeed for more than 3 seconds, identify the category of percent of overspeed based on the three categories of overspeed shown in Table 1. Refer to the latest revision of Service Bulletin No. SB-369 for additional details.

Table 1
Overspeed Values for TEO-540-A1A Engines

Overspeed Category	rpm	Corrective Action
Engine overspeed less than 5% in excess of maximum rated rpm for more than 3 seconds	2501 to 2624	a. Identify and correct the cause of the overspeed. b. In the engine logbook, record the overspeed incident and any inspections and corrective action.
Engine overspeed between 5% and 10% in excess of maximum rated engine rpm for more than 3 seconds.	2625 to 2749	a. Identify and correct the cause of the overspeed. b. Complete the “Cylinder Overspeed Inspection” procedure in this chapter. c. Refer to Chapter 12-10: (1) Drain the lubricating system. (2) Remove and examine the oil suction screen and oil filter for metal contamination. If any unexplained metal accumulation is found, identify and correct the cause before putting the engine back into service. d. Refer to Chapter 72-40. Disconnect both the inlet and outlet attaching hardware from the turbochargers and examine the compressor and turbine wheels for damage. Examine the shaft-wheel assembly for free turning and for vertical and lateral motion, which are evidence of damaged center housing bearings. If damage in these areas is found, send the engine to Lycoming Engines for evaluation before putting the engine back into service. e. Complete the “Valve Train Overspeed Inspection” procedure in this chapter. f. In the engine logbook, record the overspeed incident and any inspection and corrective action.

**Table 1 (Cont.)
Overspeed Values for TEO-540-A1A Engines**

Overspeed Category	rpm	Corrective Action
Engine overspeed more than 10% in excess of maximum rated engine rpm for any duration	2750 or more for any length of time	a. Remove the engine from the aircraft. Refer to the “Engine Removal Procedure” in Chapter 72-00. b. It is recommended the engine be sent to Lycoming Engines for customized evaluation. Include a description of the overspeed incident, amount of overspeed, and duration. c. In the engine logbook, record the overspeed incident and any inspections and corrective action. OR Refer to Chapters 72-05 and 72-20, and the latest revision of Service Bulletin No. SB-240 to: <ul style="list-style-type: none"> • Disassemble the engine • Complete an inspection of the engine • Replace any parts that are damaged or not in compliance • Replace any other parts that must be replaced at overhaul or upon removal

(3) Cylinder Overspeed Inspection

- (a) Complete the “Cylinder Compression Check Procedure” in Chapter 72-30 on all cylinders as a check for the sealing quality of the rings and valves.
- (b) Use a borescope or equivalent instrument to examine the walls of each cylinder for scoring which could be caused by a stuck or broken piston ring. Refer to the “Cylinder Borescope Inspection” procedure in Chapter 72-30.

(4) Valve Train Overspeed Inspection

- (a) Either repeated moments or short periods of operation in the overspeed region increase the rate of wear at an accelerated pace in the parts that make up the valve train and consequently decrease engine reliability. In addition to the checks completed on the engine during a 1000-hour inspection, complete the following steps to examine the valve train before putting the engine back into service.
- (b) Use a borescope or equivalent illuminated magnifying optical device to examine the condition of the intake and exhaust valve faces and seat faces. If there is evidence of excessive wear, pounding, or grooving, replace the valve and seat (valve seats can only be replaced by an authorized vendor).
- (c) Refer to the section "Exhaust Valve and Guide Inspection" in Chapter 72-30 and the latest revision of Service Bulletin No. SB-388 to determine exhaust valve condition and stem-to-valve guide clearance condition.
- (d) Examine the external condition of valve keys, rockers, and exhaust valve guides for damage (per Chapter 72-30). Examine valve springs for coil strikes or severe bottoming of the coils. If damage to the valve springs is evident, remove them and complete the check of the compression load. Replace any valve spring that is not within limits as specified in the Special Torque Requirements Tables in Section V in Part 1 of the latest revision of the *Service Table of Limits - SSP-1776*.


- (e) Turn the crankshaft by hand to see if the valve lift is uniform or equal for all cylinders. See if valve rockers lift freely when the valves are closed. Unequal valve lift is an indication of bent push rods. Tight rockers, when valves are closed, are an indication of a tuliped valve or a damaged valve lifter. Refer to Chapter 72-30 and correct any suspected damage before putting the engine back into service.

C. Engine Overboost

- (1) Overboost is a condition in which a reciprocating engine (which has a turbocharger) exceeds maximum rated manifold pressure. While this increase in manifold pressure supports engine operation during flight, during ground operation and take-off, an excess manifold pressure can damage the engine if it is not controlled correctly. If the power control is opened too quickly, the high pressure enters the cylinders and is compressed to even higher pressure which can cause detonation, overheating, or cylinder damage.
- (2) The ECU can control overboost to a limited extent.

D. Incorrect Fuel or Fuel Contamination

- (1) Refer to Appendix A in the *TEO-540-A1A Engine Installation and Operation Manual* or the latest revision of Service Instruction No. SI-1070 for approved fuels, octane ratings, and the use of a higher grade fuel for this engine.

 **CAUTION** ONLY USE APPROVED FUELS. DO NOT OPERATE THE ENGINE WITH JET FUEL OR A LOWER OCTANE OR INCORRECT GRADE OF FUEL. UNUSUAL DETONATION CAN OCCUR AND INCREASE ENGINE TEMPERATURE AND PRESSURE WHICH CAN DAMAGE THE ENGINE

- (2) Actual damage to the engine from incorrect fuel could be in a range from unnoticeable to severe damage or failure. Primary damage to the engine caused by incorrect fuel occurs in the combustion chambers. Tuliped intake valves and burnt pistons from excessive cylinder head and oil temperatures are evidence of primary damage. If detonation has been severe enough, further damage will occur to crank pins, main bearings, counterweights, and valve train components. The extent of damage can vary accordingly based on the duration of operation, engine power level and the type of fuel used.
- (3) Any mixture of unapproved fuels and additive materials that change the octane rating from the specifications in Appendix A in the *TEO-540-A1A Engine Installation and Operation Manual* or the latest revision of Service Instruction No. SI-1070 could be harmful to the engine.
- (4) Because of many variables, it is impossible to be sure of the airworthiness of an engine that has been operated with incorrect fuel - except by detailed inspection of the engine by qualified personnel. Therefore, if the engine has been operated with incorrect fuel, regardless of the power setting or time of operation, as per the latest revision of Service Bulletin No. SB-398.
 - (a) Do not continue flight and engine operation with incorrect fuel.
 - (b) Drain the aircraft fuel system until all fuel tanks are empty in accordance with the aircraft manufacturer's installation.
 - (c) If the aircraft manufacturer has a procedure for cleaning and/or purging the aircraft fuel system after the use of incorrect fuel, follow the aircraft manufacturer's procedure. If there is no aircraft cleaning and/or purging procedure, service the aircraft fuel tanks in accordance with the aircraft manufacturer's instructions.

- (d) Remove the engine in accordance with the “Engine Removal Procedure” in Chapter 72-00.
- (e) It is recommended the engine be sent to Lycoming Engines for evaluation.

OR

Complete the following in the field in accordance with this manual:

- 1 Remove, disassemble, and clean the engine per Chapters 72-00, 72-05, and 05-30.
- 2 Complete an inspection of engine components per chapters in this manual.
- 3 During inspection of engine components, carefully look for signs of detonation such as tuliped intake valves, burnt pistons, and damage to: crank pins, main bearings, counterweights, and drive train components, and other conditions that can cause engine failure.

NOTICE: Refer to the latest revision of Service Bulletin No. SB-240 which identifies certain parts that must be replaced on engine reassembly.

- 4 Assemble the engine per Chapter 72-10 and complete an Operational Ground Check per Chapter 72-00.

E. Soaked Engine



CAUTION

WHEN AN ENGINE HAS BEEN SOAKED IN WATER, MOISTURE AND UNWANTED MATERIALS CAN CAUSE DAMAGE TO ALL SYSTEMS OF THE ENGINE. DO NOT INSTALL OR OPERATE AN ENGINE THAT HAS BEEN SOAKED OR IMMERSSED IN WATER OR OTHER FLUID UNTIL IT HAS BEEN DISASSEMBLED, CLEANED, EXAMINED AS NEEDED, ASSEMBLED, AND OPERATIONALLY TESTED TO ENSURE THE ENGINE CAN BE SAFELY PUT BACK INTO SERVICE.

NOTICE: The composition of the substance that the engine has been exposed to can affect the type and extent of the damage.

It is recommended the engine be sent to Lycoming Engines for evaluation. Include a description of the liquid in which the engine was soaked.

OR

NOTICE: The following inspection only applies to an engine soaked in water.

If the engine is soaked in a substance other than water, contact Lycoming Engines technical support at the phone number listed in the front of this manual.

Complete the following in the field in accordance with this manual.

- (1) Refer to the latest revision of Service Bulletin No. SB-357 for additional details.
- (2) Remove and disassemble the engine (per Chapters 72-00 and 72-05).
- (3) Clean the engine, especially all recessed areas where debris or silt can get trapped. Remove all debris and silt per the section “Cleaning Guidelines for a Soaked Engine” in Chapter 05-30.

- (4) Complete an inspection of engine components per chapters in this manual.
 - (a) Examine components for visible corrosion or rust (or evidence thereof) per Chapters 72-20 and 72-30. Where possible, remove any rust or corrosion.
 - (b) Look for pitting on the cylinder and piston. If pitting is found, replace the component. Do not re-install a pitted cylinder or pitted piston.
 - (c) Visually examine components for embedded silt or debris contamination on bearing surfaces, pistons, mounting flanges, or on any porous surfaces. Remove all silt and debris from the component. If the embedded silt or debris cannot be removed, replace the component.
- (5) Replace parts per the latest revision of Service Bulletin No. SB-240 which identifies parts that must be replaced during engine assembly.
- (6) Make sure all oil passages, bored holes, oil and fuel hoses are clean and unobstructed and have no debris.
- (7) Once the engine is cleaned and reassembled, make sure it is in conformance with all required fits and clearances (per the latest revision of the *Service Table of Limits - SSP-1776*).
- (8) Assemble the engine per Chapter 72-10.
- (9) Refer to the Airframe Maintenance Manual and make sure all airframe interface fuel and oil lines, intake, and exhaust, and the oil cooler are clean and have no debris or silt to prevent re-contamination of the engine after the engine is installed in the airframe and re-connected to airframe interface components.
- (10) Install the engine in the airframe per instructions in the *TEO-540-A1A Engine Installation and Operation Manual*.
- (11) Record and complete the “Oil Change Procedure” per Chapter 12-10.
- (12) Complete an Operational Ground Check per Chapter 72-00 to make sure the engine is operating correctly before returning the engine to service.

F. Engine on Fire or Near a Fire

Replace any components exposed to a fire or heat from a fire.

It is recommended an engine exposed to a fire or the heat from a fire be sent to Lycoming Engines for evaluation. Include a description that the engine was in or near a fire or external heat.

OR

Complete the following in the field in accordance with this manual:

- (1) Remove, disassemble, and clean the engine (per Chapters 72-00, 72-05, and 05-30)
- (2) Complete an inspection of engine components per chapters in this manual.

NOTICE: Refer to the latest revision of Service Bulletin No. SB-240 which identifies certain parts that must be replaced on engine reassembly.

- (3) Assemble the engine per Chapter 72-10 and complete an Operational Ground Check per Chapter 72-00.

G. Hydraulic Lock

 **WARNING** DO NOT OPERATE THE ENGINE IF HYDRAULIC LOCK IS SUSPECTED. HYDRAULIC LOCK CAN CAUSE DAMAGE TO THE ENGINE.

Hydraulic lock is caused by liquid accumulation in either the Induction System or the cylinder assembly.


- (1) The liquid prevents movement of the piston during the compression stroke.
- (2) Damage to the engine occurs when the other cylinders fire, which forces the piston in the liquid-filled cylinder through the compression stroke.
- (3) Damage to an engine from hydraulic lock can be extensive due to the high forces. These forces can damage connecting rods, pistons, cylinder assemblies, piston pins, the crankcase, and the crankshaft.
- (4) Hydraulic lock can occur as a result of any of the following:
 - Incorrect operation of the fuel drain valve adapter assembly.
 - Incorrect starting procedures.
 - Failure to remove preservative oil from an engine that had been in storage.
- (5) It is recommended an engine suspected of having hydraulic lock be sent to Lycoming Engines for evaluation. Include a description and details of the hydraulic lock.

OR

Examine the engine for hydraulic lock in the field as follows:

- (a) Remove all cylinders as per the “Cylinder Removal” procedure in Chapter 72-30.
- (b) Refer to Chapter 72-20 to remove and examine the connecting rods.
- (c) If all connecting rods are in compliance with the specified criteria in the latest revision of the *Service Table of Limits - SSP-1776*, install the connecting rods.
- (d) If any connecting rod is not in compliance with acceptance criteria, disassemble the engine to examine the crankcase and crankshaft as per Chapters 72-05 and 72-20.

H. Volcanic Ash/Particulate Contamination

 **CAUTION** IF VOLCANIC ASH IS SUSPECTED ON THE ENGINE, DO NOT INHALE IT OR TOUCH IT WITH BARE HANDS OR GET IT IN YOUR EYES. WEAR PERSONAL PROTECTIVE EQUIPMENT. **DO NOT USE WATER TO RINSE IT OFF.** THE VOLCANIC ASH CAN CONTAIN ACIDIC COMPOUNDS WHICH MUST NOT BE INHALED OR TOUCHED SINCE THEY CAN CAUSE INJURY.

- (1) Given the dynamic conditions of volcanic ash, Lycoming recommends that engines not be operated in areas where volcanic ash is seen in the air or on the ground. Ash on the ground and runways can inadvertently get into the engine compartment and cause engine damage during landing or take-off.
- (2) If volcanic ash or particulates get into the engine oil, engine malfunction and/or failure can occur from abrasive wear.
- (3) In volcanic ash fall-out or high sand or dust areas, after the engine cools, install inlet and exhaust covers to prevent entry of airborne volcanic ash into the engine.
- (4) In the event that the engine has been in particulate-laden atmospheres, especially volcanic ash clouds or with ash on the ground, complete the standard actions in Table 2. Refer to Service Instruction No. SI-1530 for additional details.

Table 2
Action to Take in Volcanic Ash Conditions

Maintenance after flight...	Maintenance after 10 hours of operation or the next flight...
Wear personal protective equipment (gloves, respiratory, and eye protection). Per the aircraft manufacturer's instructions, thoroughly remove the ash or particulate from the aircraft by hand brushing or air/vacuuming. Make sure that all ash is removed from the engine and cowling.	Wear personal protective equipment. Examine the external engine and cowling for any particulate or ash residue. Remove any particulate or ash residue per the aircraft manufacturer's instructions.
Complete the post-flight inspection. Particularly, examine the induction filters, induction system, and engine baffles for blockage or damage.	Complete the pre-flight inspection per the Pilot's Operating Handbook (POH).
Immediately, complete an oil change and replace the oil filter. Collect an oil sample and have a spectrographic analysis done on the oil sample. Compare this analysis with past oil analyses to determine engine wear or contamination. Refer to Chapter 12-10.	Change the oil and replace the oil filter. Collect an oil sample for spectrographic analysis. Compare the results against the last oil sample to identify engine wear or effects of contamination. As a precaution, complete another oil change and analysis of another oil sample again. Refer to Chapter 12-10.
Replace the intake air filter, as per the aircraft manufacturer's instructions to remove any internal contamination that can cause premature wear because of the highly abrasive effects from most solid particles.	Replace the intake air filter as a precaution to be sure there are no effects from particulate contamination. Replace the intake air filter again after the next flight.
Examine the external condition of the engine, all accessories, external fuel and oil cooling air baffles, oil hoses, and all other components for corrosion or scoring. Identify any possible damage caused by high speed impact from solid particles and corrosive effects caused by the chemical composition of volcanic ash.	Examine the external condition of the engine, all accessories, external fuel and oil cooling air baffles, oil hoses, and all other components for corrosion or scoring. Identify any possible damage caused by high speed impact from solid particles and corrosive effects caused by the chemical composition of the volcanic ash.
Drain all other fuel/fluids from the engine and replace with clean fluids. Replace the disposable airframe fuel filter or remove and clean the fuel inlet screen, as per the aircraft manufacturer's instructions.	Remove and examine the airframe fuel filter or fuel inlet screen to identify any remnants of contamination. Replace the airframe fuel filter or clean the fuel inlet screen if contamination is found.
Examine seals for damage and leaks. Replace damaged or leaky seals.	Monitor oil temperature and pressure for indications of engine problems during flight.
<p align="center"> CAUTION</p> <p>DO NOT USE HIGH PRESSURE AIR SPRAY ON THE WIRING HARNESS.</p> <p>Clean the engine, except the wiring harness, with a high-pressure air spray. Be sure to clean the cooling fins on the cylinders.</p>	

I. Valve Sticking

(1) The primary causes of intake or exhaust valve sticking are:

- (a) Accumulated contaminants in the oil can collect on valve stems and/or guides to prevent valve movement and cause intermittent engine hesitation or “miss.” If the contamination deposits are not removed, the valve becomes stuck and causes engine damage.
- (b) Conditions that can increase oil contamination and valve sticking include:
 - High ambient temperature
 - Slow flight with reduced cooling
 - High lead content in fuel
 - Oil changes and oil filter replacement not done as frequently as necessary. Refer to the “Oil Servicing Schedule” in Chapter 12-10.
 - Induction system not sealed - unfiltered air enters engine
 - Cooling air baffles and/or baffle strip deterioration
 - Sudden cool down of the engine that can occur with a rapid descent with reduced power or engine shutdown without sufficient engine cooling.

NOTICE: If valve sticking is a problem, refer to the latest revisions of Service Letter No. L197 and Service Instruction No. SI-1425 and complete the 1000-hour inspection in Chapter 05-20. Refer to the section “Corrective Action for Valve Sticking” in Chapter 72-30.

If the 1000-hour inspection is completed before 1000 hours of operation because of valve sticking, complete the scheduled 1000-hour inspection after the next 1000 hours of engine operation from the time of this inspection unless valve sticking occurs again.

J. Oil Starvation/Sudden Loss of Oil Pressure

(1) To operate correctly at various attitudes, the engine must be supplied with a sufficient quantity of lubricating oil. Unless there is an adequate quantity of lubricating oil at all times during flight, loss of oil pressure can occur.

NOTICE: Refer to Appendix A of the *TEO-540-A1A Engine Installation and Operation Manual* for the minimum oil quantity.

(2) Very often a sudden loss of oil pressure is quickly followed by a sudden rise in oil temperature.

(3) As a preventive measure, before every take-off, complete the "Oil Level Check" in Chapter 12-10. Make sure the oil level is above the minimum specified level in Appendix A of the *TEO-540-A1A Engine Installation and Operation Manual*.

NOTICE: Circumstances which cause loss of oil pressure can be different which makes prediction of the extent of damage to the engine or future engine reliability difficult. In case of oil pressure loss or engine operation with oil below the minimum operating level, the most conservative action is to remove the engine, (Chapter 72-00), disassemble the engine (Chapter 72-05), and completely examine all engine components per chapters herein. Any decision to operate an engine that had loss of oil pressure without an inspection must be the responsibility of the agency putting the aircraft back into service.

- (4) Any time oil pressure falls below the minimum level, refer to the latest revision of Service Bulletin No. SB-399, identify the root cause as per the following protocol of progressive steps:
- (a) Complete the “Oil Level Check” in the oil sump (per Chapter 12-10). If no oil is visible on the oil level gage (dipstick), drain and collect the oil and measure the oil quantity.
 - (b) If the oil level is sufficient, complete the check of the oil pressure indication system accuracy. If the oil pressure gage is not operating correctly, replace it.
 - (c) Examine oil line connections for leaks. Tighten any loose connections per the torque values in the latest revision of the *Service Table of Limits - SSP-1776* and look for leaks. Replace leaking oil hoses per Chapter 72-50.
 - (d) Per Chapter 12-10, complete the “Oil Suction Screen Removal/Inspection/Cleaning/Installation” at the oil sump and the “Oil Filter Inspection.” Look for blockage or metal deposits. If metal or blockage is found, remove the material and identify the origin of material and correct the root cause.
 - (e) Examine the oil pump for malfunction. Replace the oil pump if it is not operating correctly. Refer to Chapter 72-25.
 - (f) If the oil pressure indication system is operating correctly and there has been confirmation that oil pressure loss/oil starvation has occurred, contact Lycoming Engines’ Technical Support.

K. Metal Contamination of the Lubrication System

- (1) If metallic particles/residue, metal shavings or metal flakes is found in the engine oil after oil servicing, refer to the “Identification of Metallic Solids After Oil Servicing” section in Chapter 12-10 and complete the recommended corrective action.

NOTICE: Do not disassemble the PMA, if metal contamination is found replace the PMA.

- (2) If magnetic particles/residue, shavings, or flakes are identified, remove and examine the Permanent Magnet Alternator (PMA) for possible ferrous metal contamination.

L. NTO & TLO Illumination on the Control Panel


NOTICE: When the ignition is turned ON, each control channel will illuminate all warning lamps simultaneously to perform a bulb check.

- (1) The No Take-Off (NTO) signals are connected by wire to each channel of the ECU. There is a separate lamp for each ECU channel. The wires for those signals connect through separate connectors on the ECU. Either channel of the ECU can turn on its NTO signal independent of the other channel. However, if inter-channel communications are operating correctly, both channels will turn on their NTO signals if either channel senses an NTO fault. The NTO lamp illuminates when a serious fault has been detected by the ECU. A serious fault causes degradation of the safety margins of the ECU even though the engine appears to be operating correctly.

- (2) The Time-Limited Operation (TLO) lamp is connected through a single channel of the ECU. However, either ECU channel can turn on this signal independent of the other if both channels are functioning correctly. The TLO lamp illuminates if there is a condition that causes a Time Limited Operation or TLO. If the engine is operated for more than 20 hours with a TLO fault, that has not been corrected and cleared, the NTO lamp will illuminate.
- (3) The Fault Found Lamp (FFL), if applicable, connects to the ECU through a single channel. However, either channel can turn on the signal independent of the other if both channels are operating correctly. The FFL lamp illuminates when a fault, which has no safety effect on the EECs, is detected. The fault must be corrected at the next routine service interval. This lamp could be out of view by the pilot and visible only to Maintenance personnel.

M. Propeller Strike, Sudden Engine Stoppage or Loss of a Propeller Blade Tip

- (1) This section includes recommendations for aircraft engines that have had propeller/rotor damage as well as any of the following.
 - Separation of the propeller/rotor blade from the hub
 - Loss of a propeller or rotor blade tip
 - Sudden stoppage
 - Any incident, whether or not the engine is operating, where repair of the propeller is necessary
 - Any incident during engine operation where the propeller has impact on a solid object which causes a decrease in rpm and where a structural repair of the propeller is necessary. This incident includes propeller strikes against the ground. Although the propeller can continue to turn, damage to the engine can occur, possibly with progression to engine failure.
 - Sudden rpm drop on impact to water, tall grass, or similar yielding medium where propeller damage does not usually occur.
- (2) A propeller strike can occur at taxi speeds and during touch and go operations with propeller tip ground contact. In addition, propeller strikes also include situations where an aircraft is stationary, and a landing gear collapse occurs causing one or more blades to be bent, or where a hangar door (or other object) hits the propeller blade. These instances are cases of sudden engine stoppage because of potentially severe side loading on the crankshaft propeller flange, front bearing, and seal.
- (3) Recommended Corrective Action for Propeller Strikes

 **CAUTION** BASED UPON THE ACCUMULATED ENGINEERING, TECHNICAL AND HISTORICAL DATA AVAILABLE, LYCOMING ENGINES **PROHIBITS** STRAIGHTENING OR GRINDING OF BENT CRANKSHAFT PROPELLER FLANGES TO RESTORE MAXIMUM RUN-OUT SPECIFICATION AS NOTED IN THE LATEST REVISION OF THE SERVICE TABLE OF LIMITS - SSP-1776. IF THE CRANKSHAFT PROPELLER FLANGE IS BENT, REPLACE THE CRANKSHAFT. **DO NOT TRY TO STRAIGHTEN OR GRIND THE CRANKSHAFT PROPELLER FLANGE.** REFER TO THE LATEST REVISION OF SERVICE BULLETIN NO. 201.

⚠ CAUTION DAMAGE TO A PROPELLER IS SERIOUS AND CAN CAUSE THE ENGINE TO BE UNAIRWORTHY.

- (a) Circumstances of a propeller strike cannot always be used as predictors of the extent of engine damage or its future reliability. There can be varying degrees of damage to an engine and propeller from a propeller strike. The initial damage can be hidden but could become progressively worse with time and wear.
- (b) Given these possibilities and the fact that there is no identified clear, quantifiable threshold limit or gradient standard to reliably measure the extent of damage to an engine, Lycoming Engines can only recommend **BEFORE FURTHER FLIGHT**, that you complete the tasks in the sequential order shown in the Engine Inspection Checklist After Propeller Strike for TEO-540-A1A Engines (in this chapter) as corrective action for a propeller strike. Make a copy of the checklist and complete it.

NOTICE: The agency that returns the aircraft to service is responsible for the decision to operate an engine that had a propeller strike. Lycoming Engines does not take responsibility for the decision to return the engine to service after a propeller strike. Refer to the latest revision of Service Bulletin No. SB-533.

Engine Inspection Checklist After Propeller Strike for TEO-540-A1A Engines		
Engine Serial Number:		
Date Inspection Started:		Date Inspection Completed:
Sequential Task	Additional Information	Corrective Action Done/Comments
1. Examine the propeller for extent of damage; record condition of propeller.	Condition of Propeller/Corrective Action: <input type="checkbox"/> Propeller satisfactory <input type="checkbox"/> Repair propeller in accordance with propeller manufacturer's instructions <input type="checkbox"/> Replace propeller in accordance with the airframe manufacturer's instructions.	
2. Remove the propeller.	As per airframe and propeller manufacturer's instructions.	
3. Remove the engine.	Refer to Chapter 72-00	
CRANKCASE P/N:		MATCH NO:
4. Disassemble the engine - remove the crankshaft, camshaft, connecting rods, crankshaft trigger gear assembly, and internal steel parts.	Refer to Table 1 - Sequence of Engine Disassembly in Chapter 72-05	

Engine Inspection Checklist After Propeller Strike for TEO-540-A1A Engines (Cont.)		
Sequential Task	Additional Information	Corrective Action Done/Comments
5.	Complete grit-blast cleaning* of the crankcase with fine abrasive (150-grit or finer) remove all coatings on the crankcase and engine mount bosses.	Make sure there is no dirt, debris, sludge, paint, or any other substance that could prevent reliable Fluorescent Penetrant Inspection (FPI) or subsequent oil flow.
6.	Complete grit-blast cleaning* of the oil sump and engine mount bosses with fine abrasive (150-grit or finer).	Make sure there is no dirt, debris, sludge, paint, or any other substance that could prevent reliable FPI or subsequent oil flow.
7.	Complete grit-blast cleaning* of the engine mount brackets (if used) with fine abrasive (150-grit or finer).	Make sure there is no dirt, debris, sludge, paint, or any other substance that could prevent reliable FPI or subsequent oil flow.
8.	Complete grit-blast cleaning* of the accessory housing with fine abrasive (150-grit or finer).	Make sure there is no dirt, debris, sludge, paint, or any other substance that could prevent reliable FPI or subsequent oil flow.
9.	Remove and discard the existing crankshaft gear bolt and lockplate.	Refer to the “Crankshaft Disassembly” procedure in Chapter 72-20.
10.	Examine the crankshaft.	Refer to the “Crankshaft Inspection” procedure and checklist in Chapter 72-20.
11.	Examine, the crankshaft counter-bored recess, the alignment dowel especially at the base where it goes into the crankshaft, the bolt hole threads, and the crankshaft trigger gear assembly for wear, galling, corrosion, and fretting.	Refer to the latest revision of Service Bulletin No. 475. If the bolt hole threads are damaged, they cannot be repaired. Replace the crankshaft.
12.	Clean the crankshaft, camshaft, crankshaft trigger gear assembly, counterweights, rollers and bushings.	Refer to procedures and guidelines in Chapter 05-30. Make sure there is no dirt, debris, sludge, paint, or any other substance that could prevent reliable magnetic particle inspection or subsequent oil flow.
* Refer to the “Grit-Blast Procedure” in Chapter 05-30.		

Engine Inspection Checklist After Propeller Strike for TEO-540-A1A Engines (Cont.)		
Sequential Task	Additional Information	Corrective Action Done/Comments
13.	Clean the following internal parts made of steel: <ul style="list-style-type: none"> • Connecting Rods • Piston pins • Rocker shafts • Accessory drive gears • Permanent Magnet Alternator (PMA) drive gear • Idler and oil pump shafts • Shaft gears and impellers 	Refer to Chapter 05-30.
<p>⚠ CAUTION BASED UPON THE ACCUMULATED ENGINEERING, TECHNICAL, AND HISTORICAL DATA AVAILABLE, LYCOMING ENGINES PROHIBITS STRAIGHTENING OR GRINDING OF BENT CRANKSHAFT PROPELLER FLANGES TO RESTORE MAXIMUM RUN-OUT SPECIFICATION. IF THE CRANKSHAFT PROPELLER FLANGE IS BENT, REPLACE THE CRANKSHAFT. DO NOT TRY TO STRAIGHTEN OR GRIND THE CRANKSHAFT PROPELLER FLANGE. REFER TO THE LATEST REVISION OF SERVICE BULLETIN NO. SB-201.</p>		
CRANKSHAFT P/N:		S/N:
14.	Measure the flange run-out on the crankshaft.	Refer to the latest revisions of both Service Bulletin SB-240 and Part I of the <i>Service Table of Limits - SSP-1776</i> for crankshaft flange run-out tolerance. Record the crankshaft flange run-out measurement.*
		<input type="checkbox"/> Flange run-out within acceptable limits - use crankshaft <input type="checkbox"/> Replace crankshaft
15.	Measure the main bearing run-out on the crankshaft.	Refer to the latest revision of Part I of the <i>Service Table of Limits - SSP-1776</i> for the main bearing run-out tolerance Record the main bearing run-out measurement.*
		<input type="checkbox"/> Main bearing run-out within acceptable limits - use crankshaft <input type="checkbox"/> Replace crankshaft
16.	Measure the polished dimensions on the main journals.	Refer to the latest revision of Part I of the <i>Service Table of Limits - SSP-1776</i> for the dimensions on the main journals Record the dimensions of the main journals.*
		<input type="checkbox"/> Main journals within acceptable limits - use crankshaft <input type="checkbox"/> Replace crankshaft
17.	Measure the polished dimensions on the pin journals.	Refer to the latest revision of Part I of the <i>Service Table of Limits - SSP-1776</i> for the dimensions on the pin journals Record the dimensions of the pin journals.* Dimension: _____
		<input type="checkbox"/> Pin journals within acceptable limits - use crankshaft <input type="checkbox"/> Replace crankshaft
* If the measurement or dimension is out of tolerance, discard the crankshaft and replace it with a serviceable crankshaft. Install the crankshaft per "Crankshaft Installation" procedure in Chapter 72-20.		

Engine Inspection Checklist After Propeller Strike for TEO-540-A1A Engines (Cont.)					
Sequential Task		Additional Information		Corrective Action Done/Comments	
18.	Complete a check of the connecting rods parallelism.	Refer to the “Connecting Rod/Parallelism/Squareness Check” in Chapter 72-20 for measurement instructions. Record the parallelism measurement for each connecting rod. Replace all connecting rods not in compliance with measurements in the latest revision of Part I of the <i>Service Table of Limits - SSP-1776</i> (Reference 503).	Parallelism Measurement		
			Connecting Rod 1		
			Connecting Rod 2		
			Connecting Rod 3		
			Connecting Rod 4		
			Connecting Rod 5		
			Connecting Rod 6		
19.	Complete a check of connecting rod squareness.	Refer to the section “Connecting Rod Parallelism/Squareness Check” in Chapter 72-20. Record the squareness measurement for each connecting rod. Replace all connecting rods not in compliance with measurements in the latest revision of the <i>Service Table of Limits, SSP-1776</i> (Reference 504).	Squareness Measurement		
			Connecting Rod 1		
			Connecting Rod 2		
			Connecting Rod 3		
			Connecting Rod 4		
			Connecting Rod 5		
			Connecting Rod 6		
NOTICE: The magnetic particle inspection must be done by a certified technician as per the latest revision of Service Instruction No. 1285.					
20.	Complete a magnetic particle inspection on the crankshaft.†	Record test results.	<input type="checkbox"/>	Magnetic particle test results acceptable	
			<input type="checkbox"/>	Replace crankshaft	
21.	Complete a magnetic particle inspection on the camshaft.†	Record test results.	<input type="checkbox"/>	Use camshaft	
			<input type="checkbox"/>	Replace camshaft	
22.	Complete a magnetic particle inspection on the crankshaft counterweights.† Examine the counterweight bushing bores in both the counterweights and the crankshaft.	Record test results.	Replace all counterweight pins, bushings, end plates and snap rings -regardless of their condition.		
23.	Complete a magnetic particle inspection on the connecting rods.†	Record test results.	Replace connecting rod bolts and nuts - regardless of condition. Refer to the latest revision of Service Instruction 1458 for assembly instructions.		
24.	Complete a magnetic particle inspection on the crankshaft trigger gear assembly.† Examine the gear end as per the latest revision of Service Bulletin No. 475.	Record test results.	<input type="checkbox"/>	Use crankshaft trigger gear assembly	
			<input type="checkbox"/>	Replace crankshaft trigger gear assembly	
† Refer to the section “Non-Destructive Testing” in this chapter.					

Engine Inspection Checklist After Propeller Strike for TEO-540-A1A Engines (Cont.)		
Sequential Task	Additional Information	Corrective Action Done/Comments
25. Complete a magnetic particle inspection† on the following internal parts made of steel: <ul style="list-style-type: none"> • Accessory drive gears • PMA drive gear • Idler and oil pump shafts • Shaft gears and impellers • Piston pins • Connecting rods 	Record test results.	Use Replace <input type="checkbox"/> <input type="checkbox"/> Accessory drive gears <input type="checkbox"/> <input type="checkbox"/> PMA drive gear <input type="checkbox"/> <input type="checkbox"/> Idler and oil pump shafts <input type="checkbox"/> <input type="checkbox"/> Shaft gears and impellers <input type="checkbox"/> <input type="checkbox"/> Piston pins <input type="checkbox"/> <input type="checkbox"/> Connecting Rods
26. Complete the visual inspection and Fluorescent Penetrant Inspection (FPI) on the crankcase. Closely examine the forward crankcase bearing support and adjacent structure.	Record test results.	<input type="checkbox"/> Use crankcase <input type="checkbox"/> Replace crankcase
27. Complete the visual inspection and FPI on the oil sump.	Record test results.	<input type="checkbox"/> Use oil sump <input type="checkbox"/> Replace oil sump
28. Complete the visual inspection and FPI on the engine mounts.	Record test results.	<input type="checkbox"/> Use engine mounts <input type="checkbox"/> Replace engine mounts
29. Complete the visual inspection and FPI on the accessory housing.	Record test results.	<input type="checkbox"/> Use accessory housing <input type="checkbox"/> Replace accessory housing
30. Complete the visual inspection and FPI on the oil pump impeller.	Record test results.	<input type="checkbox"/> Use impeller <input type="checkbox"/> Replace impeller
31. Examine the PMA in accordance with the PMA manufacturer's instructions.	Record test results.	<input type="checkbox"/> Use PMA <input type="checkbox"/> Replace PMA
32. Examine the pistons per instructions in Chapter 72-30 and the latest revision of the <i>Service Table of Limits - SSP-1776</i> .	Record test results.	<input type="checkbox"/> Pistons acceptable <input type="checkbox"/> Replace pistons
33. Refer to the latest revision of Service Bulletin No. 240 to identify any parts that must be replaced during engine assembly.	Record parts that must be replaced.	
34. Install a new crankshaft gear bolt and new lockplate.	Refer to the "Crankshaft Trigger Gear Assembly Installation" procedure in Chapter 72-20.	
35. Replace all of the roller tappets with new or serviceable roller tappets.	Refer to Chapter 72-20 in this manual.	

Engine Inspection Checklist After Propeller Strike for TEO-540-A1A Engines (Cont.)			
Sequential Task		Additional Information	Corrective Action Done/Comments
36.	Replace all of the counterweight bushings on the crankshaft with new counterweight rollers and bushings.	Refer to Chapter 72-20 in this manual	
37.	Review the documents of all engine-mounted accessories including the propeller governor (if installed), etc. for continued airworthiness instruction.		
38.	Assemble and install the engine. Install the propeller and test the engine. Complete an Operational Ground Check of the engine.	In accordance with instructions in Chapters 72-00 and 72-10.	
39.	Complete "Field Run-In" (if applicable) and "Engine Initiation".	Refer to the "Field Run-In" and "Engine Initiation" chapters in the <i>TEO-540-A1A Engine Installation and Operation Manual</i> .	
40.	Record maintenance findings and any corrective action.		
UNAIRWORTHY PARTS:			
ADDITIONAL WORK/INSPECTIONS NECESSARY:			
OUTCOME OF INSPECTION- SUMMARY NOTES:			

2. Non-Destructive Testing (Magnetic Particle Inspection and Fluorescent Penetrant Inspection.)

Refer to the latest revision of Service Instruction No. SI-1285 for additional details.

- A. Non-destructive testing (NDT) that can be done on engine components includes Magnetic Particle Inspection (MPI) and Fluorescent Penetrant Inspection (FPI). The purpose of the NDT is to identify the presence or potential of structural failures in an engine component.

The MPI is used for detection of discontinuities on the surface and/or sub-surface of ferromagnetic materials such as iron, nickel, cobalt, and some of their alloys.

The FPI is used to identify casting, forging and welding surface defects such as hairline cracks, surface porosity, leaks in new products, and fatigue cracks on in-service components.

- B. Penetrant Materials Used for NDT

Do not use visible dye for MPIs or FPIs because visible dye penetrant materials have an adverse effect on future penetrant inspections which can cause indications to be tightly closed and therefore missed during future inspections.

- C. Requirements for NDT Personnel

Personnel who complete the Magnetic Particle and Fluorescent Penetrant Inspections on Lycoming engine components must be qualified and certified to a written procedure in accordance with *NAS-410, Certification and Qualification of NDT personnel*. Also, personnel who make the "accept" or "reject" decisions during the inspections must be qualified and certified to at least Level II in accordance with NAS-410.

- D. NDT Inspection Procedure Requirements and Guidelines

There must be written procedures for the Magnetic Particle Inspection and the Fluorescent Penetrant Inspection that have been approved by someone who is qualified and certified to Level III in accordance with NAS-410.

- E. Before NDT, clean the components per the "Cleaning Method for Non-Destructive Testing" in Chapter 05-30.

- F. Inspection Guidelines

- (1) The inspections must be done per established acceptance criteria to ensure component conformance.
- (2) A 3 power to 10 power magnifying glass must be used to evaluate indications.
- (3) If a Magnetic Particle Inspection is difficult to do on an odd-shaped part, the Fluorescent Penetrant Inspection can be used if the acceptance criteria are concerned about surface indications only.

12-10 - SERVICING - REPLENISHING

1. Refueling

⚠ CAUTION ONLY USE APPROVED FUELS. DO NOT OPERATE THE ENGINE WITH JET FUEL OR A LOWER OCTANE OR INCORRECT GRADE OF FUEL BECAUSE IT CAN CAUSE UNUSUAL DETONATION WHICH COULD DAMAGE THE ENGINE.

- A. Refer to the latest revision of Service Instruction No. SI-1070 for Lycoming Engine's approved fuels, octane ratings, and the use of a higher grade fuel for this engine. Do not use any fuel that has a lower octane rating than the fuel specified for your engine.
- B. Refer to the aircraft manufacturer's manual for any other approved fuels and fuel capacity.

2. Oil Level Check

⚠ WARNING DO NOT FLY THE AIRCRAFT IF THE OIL LEVEL IS LESS THAN THE MINIMUM OIL LEVEL IDENTIFIED IN APPENDIX A OF THE TEO-540-A1A INSTALLATION AND OPERATION MANUAL. IF THE ENGINE IS OPERATED WITH AN INSUFFICIENT OIL LEVEL, ENGINE DAMAGE CAN OCCUR. REFER TO THE SECTION "OIL STARVATION/SUDDEN LOSS OF OIL PRESSURE" IN CHAPTER 05-50.

- A. The oil in the engine must be kept at the correct level for the engine to operate correctly.
- B. Measure the oil level of an engine before every flight as follows:

- (1) Pull out the oil level gage assembly (dipstick) from the oil filler extension (Figure 1).
- (2) Wipe all oil from the dipstick end with a clean, lint-free cloth. Do not let any lint or dirt remain on the dipstick or get in the oil filler extension.
- (3) Insert the dipstick fully back into the oil filler extension, threaded all the way down to the oil sump and then remove the dipstick.
- (4) Look at the oil level indication on the dipstick end.
- (5) If the oil level is not sufficient, add the correct oil through the oil filler extension. Refer to the section "Add Oil to the Engine" in this chapter.

- C. Re-install the dipstick securely.

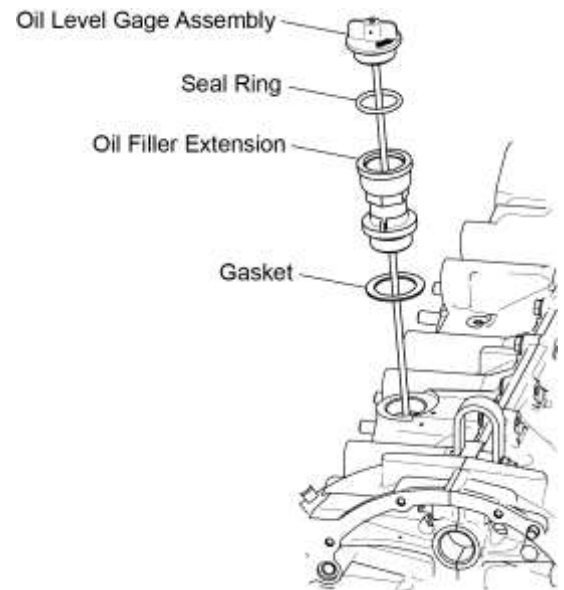



Figure 1
Oil Filler Extension and
Oil Level Gage Assembly (Dipstick)

3. Oil Consumption

NOTICE: To ensure accurate calculation of oil consumption, each time oil is added to the engine, record the amount of oil added in the engine logbook.

- A. Use the following formula to calculate the maximum allowable oil consumption limits for this engine and record the value in the engine logbook. Compare this oil consumption value to past oil consumption values.

$$0.006 \times \text{BHP} \times 4 \div 7.4 = \text{Qt./Hr.}$$

 **WARNING** ONCE BREAK-IN IS COMPLETE, IF OIL CONSUMPTION IS MORE THAN THE CONSUMPTION RATES IN APPENDIX A OF THE TEO-540-A1A ENGINE INSTALLATION AND OPERATION MANUAL, DO NOT CONTINUE FURTHER FLIGHT. EXCESSIVE OIL CONSUMPTION IS AN INDICATION OF A SERIOUS PROBLEM THAT REQUIRES IMMEDIATE ATTENTION.

- B. If engine oil servicing is consistently frequent or oil consumption has increased or is excessive, refer to Chapter 12-30 for corrective action to identify and correct the cause of the excessive oil consumption before further flight.

4. Oil Type and Viscosity

- A. The correct oils to be used in the TEO-540-A1A engine are identified in Appendix A of the *TEO-540-A1A Engine Installation and Operation Manual*.

 **WARNING** DO NOT USE AUTOMOTIVE OIL IN LYCOMING ENGINES BECAUSE THEY COULD CAUSE ENGINE DAMAGE.

- B. Refer to the latest revision of Service Instruction No. SI-1014 for additional details.
- C. The only type of oil approved for turbocharged engines is ashless dispersant oil because it can withstand wide variations of ambient temperature. The ashless dispersant oil grades contain additives which have a viscosity stabilizing effect. The additives in these oils extend operating temperature range, improve cold engine starting and lubrication of the engine during the critical warm-up period, thus permitting flight through wider ranges of climate changes without a need to change oil type. However, these oils will not prevent all of the problems encountered in extremely cold environments (below +10°F (-12°C)). At these temperatures, preheating of the engine and oil supply tank will be necessary regardless of the type of oil used. Refer to the “Engine Conditions” chapter in the *TEO-540-A1A Engine Installation and Operation Manual* to apply heat to a cold engine.

5. Add Oil to the Engine

NOTICE: Each time oil is added to the engine, record the quantity of oil added in the engine logbook to calculate oil consumption.

- A. Oil Additives

If used, the anti-scuffing agent oil additive (P/N LW-16702), to decrease engine wear, is to be added to the oil sump during an oil change. Refer to the latest revision of Service Instruction No. SI-1409 for the general use of LW-16702. If the engine oil already contains an anti-scuffing agent equivalent to LW-16702, **do not** add additional LW-16702.

NOTICE: The approved oil, oil sump capacity, and the minimum quantity for engine operation are identified in Appendix A of the *TEO-540-A1A Engine Installation and Operation Manual*.

- B. To add oil to the TEO-540-A1A engine:
- (1) Pull out the oil level gage assembly (dipstick) (Figure 1) from the oil level gage tube.
 - (2) Add either new clean ashless dispersant oil or specified oil of the correct viscosity for the ambient temperature (identified in Appendix A in the *TEO-540-A1A Engine Installation and Operation Manual*) to the oil sump through the oil level gage tube.
 - (3) Measure the oil level per the “Oil Level Check” procedure in this chapter. Add more oil if necessary until the oil level in the engine is sufficient.
 - (4) In the engine logbook, record the amount of oil added to calculate oil consumption.
 - (5) Install the oil level gage assembly (dipstick) into the oil filler extension.
6. Oil Leak Check
- A. Examine the following for oil leaks:
- Oil sump drain plug
 - Oil filter
 - Oil suction screen plug
 - Oil hoses connected to the oil cooler
- B. If leaks are found, identify and correct the cause. Complete the Operational Leak Checklist for TEO-540-A1A Engines in Chapter 05-20.
- C. After the cause of the oil leak is corrected, measure the oil level. Refer to “Oil Level Check” procedure in this chapter. Add oil as necessary per the procedure “Add Oil to the Engine” in this chapter.
7. Oil Servicing Schedule

NOTICE: While compliance with the oil change schedule and inspections in Table 1 of this Service Bulletin is mandatory, in special circumstances, the oil change intervals in Table 1 can be extended by not more than 5 hours while on route to a place where the oil change can be done (on engines using aviation fuel).

Table 1
Oil Servicing Schedule

Task	Frequency
Initial oil change and oil filter replacement of any new, rebuilt, or overhauled engine, or engine returned to service after storage & Oil suction screen cleaning/inspection	After the first 25 hours of operation after initial start-up or every 4 months (whichever occurs first*) Repeat as necessary until oil consumption stabilizes.**
Routine oil change and oil filter replacement (after initial 25-hour oil change and oil filter replacement) & Oil suction screen cleaning/inspection	After every 50 hours of engine operation or every 4 months (whichever occurs first*) After replacement of any engine cylinder
* Oil change intervals must not exceed 4 months regardless of operating hours and especially if the aircraft has not been flown for at least 25 hours in a 4-month period. More frequent oil changes are recommended if the engine has been exposed to volcanic ash, particulate, sand, dust, debris, extreme weather conditions, or salt spray in coastal environments.	
** If oil consumption does not stabilize, identify and correct the cause and repeat this procedure.	

8. Oil Change Procedure

NOTICE: Refer to Table 1 for the oil servicing schedule for your engine.

An anti-scuffing oil additive can be added to the oil sump during an oil change. Refer to the “Oil Additives” section in this chapter.

Per the “Engine Operation” chapter in the *TEO-540-A1A Engine Installation and Operation Manual*, operate the engine until the oil temperature stabilizes and then shut down the engine wait at least 15 minutes after engine shutdown and then proceed with the oil change.

NOTICE: If an oil sample is to be taken, within 30 minutes after engine shutdown, complete the oil change and collect an oil sample from the oil sump. Send the oil sample in the vial to the same laboratory (that has been used in the past) for spectrographical analysis to compare past results and identify a wear trend pattern. Refer to the latest revision of Service Letter No. L171 for spectrographic oil analysis.

CAUTION THE ENGINE OIL WILL BE VERY HOT AND CAN CAUSE BURNS, HANDLE WITH CARE.

A. Drain the oil from the oil sump as follows:

- (1) Put an empty 15-quart (14-liter) capacity container under the drain plugs of the oil sump.
- (2) Remove the safety wire from the square drain plugs and discard the safety wire/cable (Figure 2).

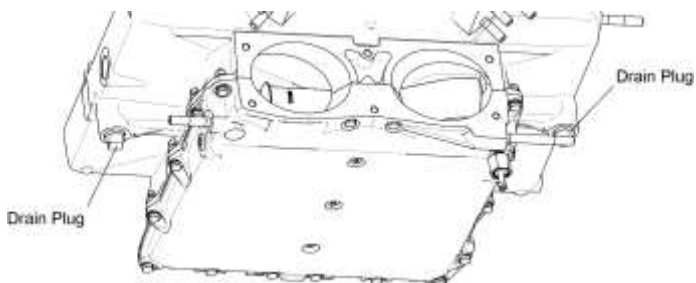


Figure 2
Oil Sump Drain Plugs

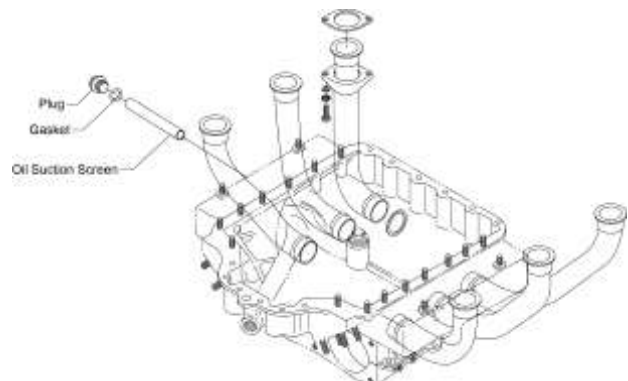


Figure 3
Suction Screen for the TEO-540-A1A

- (3) Remove the two oil sump drain plugs from the oil sump.
 - (4) For routine oil changes, collect an oil sample per the laboratory vendor’s sample oil collection procedure.
 - (5) Disconnect the hoses from the oil coolers and drain the oil coolers and hoses.
 - (6) Reconnect the hoses to the oil coolers. Torque the hose connections in accordance with the Standard Torque Tables in the latest revision of the *Service Table of Limits - SSP-1776*.
 - (7) Let the remainder of the oil drain from the engine into the collection container.
- B. Clean the threads of the drain plug(s) and the threads in the oil sump with mineral spirits, MIL-PRF-680 or equivalent degreasing solvent.

- C. Apply one to two drops of Loctite® 564™ to the threads of each oil sump drain plug and install the two oil sump drain plugs in the oil sump. Torque the drain plugs in accordance with the Standard Torque Tables in the latest revision of the *Service Table of Limits - SSP-1776*.

⚠ CAUTION MAKE SURE THAT THE OIL SUMP DRAIN PLUGS ARE INSTALLED AND TORQUED CORRECTLY TO PREVENT OIL LEAKAGE WHICH CAN CAUSE ENGINE FAILURE.

- D. Complete the "Oil Filter Replacement" procedure in section 11 in this chapter during the oil change.
- E. Complete the "Oil Suction Screen Removal/Inspection/Cleaning/Installation" procedure in section 10 of this chapter.
- F. Add oil of the correct viscosity for ambient temperature to the engine. Refer to the "Add Oil to the Engine" procedure in section 5 in this chapter.

NOTICE: If an oil hose has been disconnected or if the oil cooler was drained or replaced or after any prolonged period of engine inactivity complete the "Engine Pre-Oil Procedure" in section 9 of this chapter.

- G. Complete the "Oil Level Check" procedure in section 2 in this chapter.
- H. Safety cable/wire the oil sump drain plugs (Figure 2), suction screen plug (Figure 3), and oil filter (if applicable) in accordance with the standard practices per the latest revision of AC43.13-1B or the latest revision of Service Instruction No. SI-1566.
- I. Dispose of the oil in the collection container in accordance with environmental safety laws.
- J. Clean up any oil spilled on the engine.
- K. After all service is complete, refer to the Pilot's Operating Handbook (POH) to start the engine, complete the pre-flight run-up, stop the engine, and look for leaks in the oil system. Identify and correct the cause of any oil leak.

9. Engine Pre-Oil Procedure

Refer to the latest revision of Service Instruction No. SI-1241 for additional details.

Complete the engine pre-oil procedure on the engine at the following times:

- Before the initial start of an engine after engine installation
- After oil cooler replacement or draining
- After disconnecting any oil lines from the oil cooler circuit.
- After any prolonged period of inactivity requiring a preservation procedure per the latest revision of Service Letter No. L180

⚠ WARNING IF THE PRE-OIL PROCEDURE IS NOT DONE, HIGH-SPEED BEARING FAILURE CAN OCCUR.

NOTICE: The purpose of the engine pre-oil procedure is to internally circulate oil through the engine via a few turns of the engine crankshaft to ensure that oil pressure is sustained and that there are no oil leaks.

To complete the pre-oil procedure:

- A. If not already done, fill the oil sump with clean engine oil to the correct level per the “Add Oil to the Engine” procedure in section 2 in this chapter.
- B. Make sure that the Ignition switch, Auxiliary Fuel Pump switch, and Fuel Selector are all in the OFF position.
- C. Disconnect the oil supply line from the top of the turbocharger.
- D. Disconnect the engine air duct from the compressor housing inlet.
- E. Fill the turbocharger oil inlet port with clean engine oil and manually turn the compressor wheel several revolutions in both directions to apply a coat of oil to all journal and bearing surfaces.
- F. Reconnect the oil supply line to the top of the turbocharger.
- G. Reconnect the engine air duct to the compressor housing inlet.
- H. Fill the oil cooler with oil.
- I. Per the “Spark Plug Removal” procedure in Chapter 74-20, disconnect the ignition leads from all spark plugs and remove one spark plug from each cylinder of the engine. Remove and discard the spark plug gasket.
- J. Move the power control to the FULL OPEN position.

**CAUTION**

DO NOT ENERGIZE THE STARTER FOR PERIODS OVER 10 TO 15 SECONDS. LET THE STARTER COOL FOR 30 SECONDS AFTER EACH ENERGIZATION. IF THE STARTER FAILS TO ENERGIZE AFTER TWO ATTEMPTS, IDENTIFY AND CORRECT THE CAUSE PER THE AIRFRAME MANUFACTURER’S MAINTENANCE MANUAL.

- K. Pre-oil start cycle: Energize the starter for 10 to 15 seconds and look for evidence of oil pressure of at least 20 psi (138 kPa) within 10 to 15 seconds.

If there is no oil pressure within 10 to 15 seconds, stop energizing the starter. Wait at least 30 seconds and repeat the pre-oil start cycle.

Up to six consecutive pre-oil start cycles can be done. Afterwards let the starter cool for 30 minutes. If stable oil pressure is not achieved, stop pre-oiling and contact Lycoming Engines.

NOTICE: Unstable oil pressure or oil pressure less than 20 psi (138 kPa) could be an indication of obstructed or interrupted oil flow or air in the oil lines.

- L. If oil pressure of at least 20 psi (138 kPa) was sustained in the previous step, repeat the pre-oil start cycle to make sure oil pressure holds stable and that there is no sudden drop in oil pressure. If oil pressure is not stable or drops suddenly, stop pre-oiling, identify and correct the cause.

NOTICE: Install a new spark plug gasket whether a new or acceptable re-used spark plug is to be installed.


- M. Once the minimum oil pressure of 20 psi (138 kPa) is shown on the oil pressure gage, re-install the spark plugs each with a new gasket as per the “Spark Plug Installation” procedure in Chapter 74-20.

- N. Reconnect the ignition leads to all spark plugs.
- O. Within the next 3 hours start and operate the engine for 3 minutes at approximately 1000 rpm. Refer to either the "Engine Initiation" chapter or the "Engine Operation" chapter in the *TEO-540-A1A Engine Installation and Operation Manual*.

10. Oil Suction Screen Removal/Inspection/Cleaning/Installation

NOTICE: On the TEO-540-A1A (Figure 3) engines there is an oil suction screen in the oil sump. Clean the oil suction screen and replace the oil filter after every 50 hours of engine operation, with each oil change (unless more frequent oil changes are necessary).

- A. Remove and discard the safety/cable wire/cable from the suction screen plug (Figure 3) and oil drain plugs (Figure 2) on the oil sump
- B. Put a suitable collection container with a minimum 15-quart (14-liter) capacity under the drain plugs of the oil sump.
- C. Remove the oil sump drain plugs and drain the oil from the engine.
- D. Remove the oil suction screen plug and oil suction screen from the oil sump.
- E. Remove and discard the gasket from the oil suction screen plug.
- F. Before cleaning the oil suction screen (Figures 3 and 4), examine the oil suction screen for:
 - (1) Deformation or openings in the mesh.
 - (2) Metal particles, shavings or flakes trapped in the oil suction screen. Refer to the sections: "Identification of Metallic Solids After Oil Servicing" and "Visual Inspection of the Oil Filter Element and Oil Suction Screen" in this chapter.
- G. Clean the oil suction screen with mineral spirits or equivalent solvent.
- H. Apply a light coat of Food Grade Anti-Seize to the threads of the oil suction screen plug.
- I. Install a new gasket on the oil suction screen plug.
- J. Install the oil suction screen into the oil suction screen plug.
- K. Guide the oil suction screen and oil suction oil suction screen plug carefully into the sump threading in hand tight.
- L. Tighten the oil suction screen plug until the sealing surfaces are in contact and then tighten the oil suction screen plug an additional 135°.

 **CAUTION** MAKE SURE THAT THE OIL SUCTION SCREEN PLUG AND OIL SUMP DRAIN PLUGS ARE INSTALLED SECURELY AND SAFTIED TO PREVENT OIL LEAKAGE.

- M. Apply one to two drops of Loctite® 564™ or equivalent to the threads of the oil sump drain plugs and install the oil sump drain plugs in the oil sump. Torque the drain plugs in accordance with the latest revision of the *Service Table of Limits - SSP-1776*.
- N. Safety cable/wire the oil sump drain plugs and the oil suction screen plug in accordance with the standard practices per the latest revision of AC43.13-1B or the latest revision of Service Instruction No. SI-1566.
- O. Complete the "Add Oil to the Engine" procedure in section 2 in this chapter.

- P. After all service is complete, refer to the Pilot's Operating Handbook (POH) to start the engine, complete the pre-flight run-up, stop the engine, and look for oil leaks. Identify and correct the cause of any oil leak.

⚠ CAUTION DO NOT RETURN THE ENGINE TO SERVICE UNLESS IT OPERATES CORRECTLY AND HAS NO OIL LEAKS.

- Q. Record all oil suction screen cleaning, inspection findings, and any corrective action in the engine logbook.

11. Oil Filter Replacement

After the initial 25-hour oil filter replacement and oil change, replace the oil filter after every 50 hours of engine operation during an oil change, unless otherwise directed (per the latest revision of Service Letter No. L270). During initiation of an engine, if oil consumption has not stabilized, repeat this procedure after the next 25 hours of engine operation. If oil consumption continues to be excessive, identify and correct the cause and repeat the oil change and oil filter replacement after every 25 hours of engine operation until oil consumption stabilizes.

- A. Drain the oil from the oil sump per "Oil Change Procedure" in section 8 in this chapter.
- B. Remove the safety wire/cable (Figure 4) from the oil filter. Discard the safety wire/cable.
- C. Remove the oil filter (Figure 5) from the oil filter base.



Figure 4
Safety Wire on Oil Filter

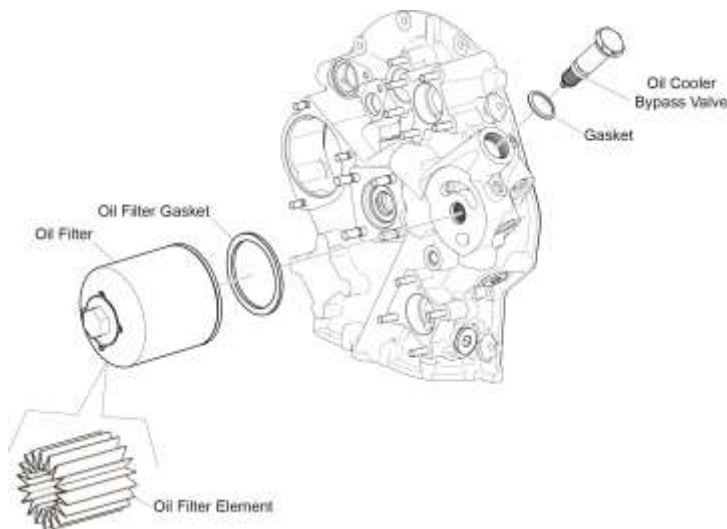


Figure 5
Oil Filter

- D. Apply Dow Corning[®] 4 or engine oil to the oil filter gasket on the new oil filter.
- E. Apply a light coating of Food Grade AA Anti-Seize or clean engine oil to the oil filter threads.
- F. Install the new oil filter on the oil filter base as shown in Figure 5.
- G. Torque the oil filter to 17 ft.-lb. (23 Nm) or per the oil filter manufacturer's instructions.
- H. Install new safety wire/cable on the oil filter (Figure 4) to keep it securely in place per the latest revision of Service Instruction No. SI-1566.
- I. Record the oil filter replacement in the engine logbook.

12. Oil Filter Inspection

NOTICE: There can be small screen molded within the propeller governor gasket. Remove this gasket and look for particle contamination on the propeller gasket screen. Replace with a new propeller governor gasket.

- A. Cut open the removed oil filter canister with an approved tool (e.g., for full-flow filters, use Champion Tool CT-470) per the tool manufacturer's instructions.
- B. Remove the paper element from the oil filter.
- C. Carefully cut the paper element at each end of the body.
- D. Carefully unfold the paper element to prevent loss of collected particles which can compromise the integrity of this inspection.
- E. Examine the material trapped in the filter. Look for shiny metallic particles/residue, shavings or flakes. Refer to the sections: "Identification of Metallic Solids After Oil Servicing" and "Visual Inspection of the Oil Filter Element and Oil Suction Screen" in this chapter.
- F. Record all inspection findings and any corrective action in the engine logbook.

13. Identification of Metallic Solids After Oil Servicing

Identification of the nature of the metallic particles found in an oil filter element or oil suction screen during an oil change is helpful as a diagnostic method. The metallic particles can be an early indication of wear or damage to engine components such as cylinders, bushings, piston pins, etc. ("Metallic particles" herein include metal particulates and/or chunks, chips, flake, hair-like strands, shavings, etc.)

Identification of the metallic particles is a progressive approach that begins with a visual inspection that can be followed with basic chemical analysis or more in-depth analysis or directly with component examination and subsequent corrective action.

NOTICE: For spectrometric oil analysis to be an effective diagnostic tool, Lycoming Engines recommends that oil samples must be taken and analyzed at each oil change.

Contact Lycoming Engines' Technical Support at the phone numbers at the front of this manual, if:

- The cause of the metal contamination cannot be found
- If the next two oil analyses show progressive increases in aluminum or iron content, complete a "Visual Cylinder Inspection" and/or "Cylinder Borescope Inspection" on each engine cylinder per Chapter 72-30.

14. Visual Inspection of the Oil Filter Element and Oil Suction Screen

When metallic particles are found on a filter element or screen, a visual inspection of the metallic particles on the filter element or oil suction screen is to be done to help identify and narrow the root source of affected engine components subject to wear or damage. The visual inspection includes four attributes:

Size - "Chunks" are metallic particles larger than 3/16-inch in size; chips are smaller than chunks. Chunks and chips require immediate analysis. Yet metallic particles can be small dust-size particulates - that is where quantity becomes more of the issue in this case.

Quantity – If more than five small particulates are on almost every panel in the oil filter element or if there is a 1/4 teaspoon full of metallic particles from an oil suction screen, these metallic particles require immediate analysis because they can be an indication of an engine component being worn or damaged.

Color – Metallic particles can vary in color: black, shiny silver or gray metal, bronze or brass – all of which can be an indicator toward the affected engine component.

Magnetic/Not Magnetic – Most ferrous alloy materials can be picked up by a magnet. However, some stainless steel and non-ferrous materials such as aluminum, magnesium, tin, cadmium, zinc, etc. cannot be picked up with a magnet.

The visual inspection procedure is slightly different for oil filter elements and screens:

Visual inspection for oil filter element:	Visual inspection for oil suction screen:
Remove the oil filter element from the oil filter canister.	Drain all fluid oil through a strainer cloth or paper to remove oil from either the oil suction screen as much as possible to enable better visibility of the metallic particles and prevent loss of metallic particles. Since quantity matters, try not to lose particles. Loss of metallic particles can compromise the integrity of this inspection.
Drain all fluid oil through a strainer cloth or paper to remove oil from the oil filter, and oil suction screen as much as possible to enable better visibility of the metallic particles and prevent loss of metallic particles. Since quantity matters, try not to lose particles. Loss of metallic particles can compromise the integrity of this inspection.	Scrape all of the remaining metallic particles onto a clean teaspoon, paper or cloth.
Open up and unravel the oil filter element on a clean sheet of white paper or cloth.	Look at metallic particles for any shiny metallic solids.
Use bright light illumination to look at the panels and folds on the filter element for any shiny metallic solids.	Look for any copper-colored metallic particles.
Look for any copper-colored metallic particles.	Use non-metallic tweezers or a pick to sort chips and particles that look different.
Estimate the size and number of metallic particles.	Estimate the size and number of metallic particles.

Typically, small metallic particles, chips, and chunks on either the oil filter element or oil suction screen during the first oil change of a new, rebuilt, or overhauled engine, are acceptable. After an initial break-in period, metal content is likely to decrease rapidly to a level that remains essentially constant.

However, on subsequent oil changes, an increased quantity of chunks, chips, and/or small metal particles in the oil can be evidence of engine part wear. This wear can increase over a period of time until premature loss of form, fit, or function occurs.

NOTICE: If the engine has been operated in dust, sand storms, volcanic ash, wildfires, etc. more particulates could be found.

Table 2 identifies field tests and guidelines for identifying types of metals as well as possible sources and the next step in the process.

Table 3 identifies the size and amount of material and the recommended corrective action.

Table 4 identifies specific corrective action for the various findings.

The type of material (Table 2), regardless of quantity, and/or the quantity and size of metallic particles (Table 3) can help determine the corrective action (Table 4) to be taken.

NOTICE: Table 2 only applies to engines that use genuine Lycoming Parts.

Table 2
Guidelines for Identification of Metal Particulates and Chips & Corrective Action

Metals/ Alloys	Tests & Characteristics	Possible Source of Origin on Lycoming Engine	Next Step
Steel or cast iron	Picked up by magnet or, will move when a magnet is placed on the opposite surface of the filter element or strainer cloth – which will prevent chips from sticking to the magnet	Camshaft lobes Gears Tappets Push rods Rocker Shafts Impellers Piston rings Cylinder barrels	Refer to Table 3 for the quantity and size of the particles
Bronze	When placed in nitric acid, turns bright green	Connecting rod bushings Rocker bushings Crankshaft bearings Intake valve guide Piston pin plug Idler gear bushing	Refer to Table 3 for the quantity and size of the particles
Nickel	Not picked up by magnet	Exhaust flange V-band coupling Gasket	Refer to Table 3 for the quantity and size of the particles
Stainless steel		Valves Exhaust components Valve seats Oil bypass valve spring Safety wire	Refer to Table 3 for the quantity and size of the particles

Table 2 (Continued)
Guidelines for Identification of Metal Particulates and Chips & Corrective Action

Metals/ Alloys	Tests & Characteristics	Possible Source of Origin on Lycoming Engine	Next Step
Chrome		Piston rings Exhaust valve stems	Refer to Table 3 for the quantity and size of the particles
Copper	When placed in nitric acid, turns bright green	Platings	Refer to Table 3 for the quantity and size of the particles
Brass	When placed in nitric acid, turns bright green	Oil suction screen Pressure relief valve spacer	Refer to Table 3 for the quantity and size of the particles
Lead		Bearings	If lead chips, chunks, or balls are found, complete Corrective Action 4 in Table 4.
Aluminum flakes	When placed in 50% solution of nitric acid and muriatic acid (approximately 30% hydrochloric acid and water), or a sodium hydroxide solution, the aluminum particles bubble and fizz and form a black residue	Crankcase Accessory housing Oil pump body Cylinder head Pistons Piston pin plugs Oil sump baffle Turbocharger inlet housing Sleeve bearings	Refer to Table 3 for the quantity and size of the particles
Magnesium		Oil sump	Refer to Table 3 for the quantity and size of the particles
Tin	Soft, malleable Not picked up by magnet When dropped onto a hot (500°F) soldering iron, tin particle will melt and fuse with 50/50 solder	Tin-plated parts	Refer to Table 3 for the quantity and size of the particles
Cadmium		Plating	Refer to Table 3 for the quantity and size of the particles
Zinc		Plating	Refer to Table 3 for the quantity and size of the particles

Table 3
Guidelines for Particle Quantity and Size on Oil Filter or Oil Suction Screen

Condition	Corrective Action (Table 4)
1 to 9 pieces of metal (1/16 in. (1.2 mm)) diameter or less)	Continue to operate the engine until the next scheduled oil change
10 to 20 pieces of shiny flake-like, non-magnetic metal (1/16 in. (1.2 mm)) diameter or less)	Corrective Action 1
10 or fewer short hair-like pieces of magnetic metal	Corrective Action 1
20 to 40 pieces of shiny flake-like non-magnetic metal	Corrective Action 2
45 to 60 small pieces of shiny flake-like, non-magnetic metal	Corrective Action 3
Pieces of metal that are chunks, greater than 3/16 in. (4.8 mm) or chips smaller than chunks <u>NOTICE:</u> A mixture of magnetic and non-magnetic material can indicate valve or ring and piston failure. <u>NOTICE:</u> Remove the bottom spark plugs to identify a non-conforming cylinder.	Corrective Action 4
1/4 teaspoonful or more of non-magnetic plating with or without a copper tint, could vary in sizes	Corrective Action 2
1/4 teaspoonful or more of non-magnetic plating with or without a copper tint, 1/16-inch or larger size could indicate bearing damage	Corrective Action 4
Pieces of shiny flake-like, non-magnetic metal (larger than 1/16 inch in diameter) with no copper tint. (Possible indication of incorrect propeller operation.)	Corrective Action 4
1/4 teaspoonful of non-magnetic brass or copper colored metal that appears coarse like sand	Corrective Action 4
1/2 teaspoonful of more of metal	Corrective Action 4

Table 3 (Continued)
Guidelines for Particle Quantity and Size on Oil or Oil Suction Screen

Condition	Source of Particles	Corrective Action (Table 4)
Chunks (3/16-inch or larger) in oil suction screen	Valve Tappet Ring Piston Bearing Machining chips	Corrective Action 3 and contact Lycoming Product Support
Bronze chips in the oil suction screen	Connecting rod bushing	Corrective Action 6
More than five bronze chips found in the oil filter or oil suction screen	Connecting rod bushing	Corrective Action 6
More than three bronze chips AND more than three aluminum chips found in the oil filter or oil suction screen	Connecting rod bushing and piston	Corrective Action 7
1/4 teaspoon or more of metallic particles and metal has gotten past the oil filter	Cylinders Bearings Piston Piston pin plugs	Corrective Action 4
1/4 teaspoon or more of metallic particles and metal has not gotten past the oil filter	Possibly only one engine cylinder is damaged or spark plug is worn or damaged	Corrective Action 5

If the cause of the metal contamination cannot be identified, speak with the Lycoming Engines Technical Support, phone number at the front of this manual.

If there is unusual aluminum, bronze, or iron contamination in the oil, make sure you have a full description of the engine model, serial number, history, oil temperatures, oil pressure, unusual performance, and properties of the metal contamination (color, size, metallic/nonmetallic, shape, etc.). This information will help Technical Support identify the cause of the contamination.

Coordinate with an appropriate oil analysis laboratory to have the material analyzed. For factory new, factory rebuilt or factory overhauled Lycoming engines within their hourly or 12-year required TBO cycle, if, contact Lycoming Engines Technical Support prior to sending the oil filter element and metallic material to Lycoming Engines for analyses.

A change in the usual wear rate of a part is not necessarily an indication of imminent failure. It is an indication that a cylinder borescope inspection, cylinder compression pressure check, etc. are necessary to identify the cause for unusual wear.

15. Recommended Corrective Action Options

Table 4
Recommended Corrective Action Options

1	<p>a. Per sections in this chapter complete:</p> <ul style="list-style-type: none"> • Oil Change Procedure • Oil Filter Replacement • Oil Suction Screen Removal/Inspection/Cleaning/Installation. <p>b. Operate the engine in flight for 25 hours.</p> <p>c. Complete the “Oil Change Procedure” again.</p> <p>d. Remove and examine the oil filter.</p> <p>e. If the oil filter is clean, resume the routine oil servicing schedule. If chunks or more than 45 metallic particles are found, ground the aircraft and proceed to Corrective Action 3.</p>
2	<p>a. Per sections in this chapter complete:</p> <ul style="list-style-type: none"> • Oil Change Procedure • Oil Filter Replacement • Oil Suction Screen Removal/Inspection/Cleaning/Installation. <p>b. Operate the engine <u>on the ground</u> for 20 to 30 minutes. Refer to the aircraft POH.</p> <p>c. Remove and examine the oil filter.</p> <p>d. If the oil filter is clean, install a new oil filter.</p> <p>e. Operate the engine in flight for 10 hours.</p> <p>f. Remove and examine the oil filter.</p> <p>g. If either the oil filter is clean, resume the routine oil servicing schedule. If chunks or more than 45 metallic particles are found, ground the aircraft and proceed to Corrective Action 3.</p>
3	<p>a. Per sections in this chapter complete:</p> <ul style="list-style-type: none"> • Oil Change Procedure • Oil Suction Screen Removal/Inspection/Cleaning/Installation – look for chunks in this screen. <p>b. If one or more chunks are found, complete the “Oil Sump Removal” procedure in Chapter 72-50.</p> <p>c. Look for chunks and metallic particles in the oil sump.</p> <p>d. If one or more chunks are found in the oil sump, examine the exhaust and intake valves, pistons, and piston rings per procedures in Chapter 72-30.</p>
4	<p>Complete the “Engine Removal Procedure” in Chapter 72-00 and send the engine to Lycoming Engines or an authorized repair facility for customized evaluation.</p> <p>or</p> <p>Complete the “Engine Disassembly Procedure” in Chapter 72-05 and examine engine components per the applicable chapters in this manual to identify and correct the cause.</p>

**Table 4 (Continued)
Recommended Corrective Action Options**

5	<p>Per Chapter 74-20, remove and examine the spark plugs. Per Chapter 72-30, complete a “Cylinder Borescope Inspection” on the cylinders. Remove the propeller governor to determine if metallic particles have spread to other parts of the engine. If the contamination has spread to other parts of the engine, proceed to Corrective Action 4.</p>
6	<p>a. Complete these procedures in Chapter 72-30:</p> <ul style="list-style-type: none"> • Cylinder Removal • Piston Removal <p>b. Per the Connecting Rod Inspection Checklist in Chapter 72-20, examine the connecting rod bushing</p>
7	<p>a. Complete these procedures in Chapter 72-30:</p> <ul style="list-style-type: none"> • Cylinder Removal • Piston Removal <p>b. Per the Connecting Rod Inspection Checklist in Chapter 72-20, examine the connecting rod bushing</p> <p>c. Complete the “Piston Inspection” procedure in Chapter 72-30. Examine the pistons for wear or damage.</p>

16. Oil Contamination Check

NOTICE: Lycoming engine models that have a propeller governor can have a small screen molded within the propeller governor gasket. Remove this gasket and look for particle contamination on the propeller gasket screen. Replace with a new propeller governor gasket.

If less than 10 metallic particles are found on this screen:

- A. Replace the propeller governor gasket.
- B. Complete an oil change.
- C. Replace the oil filter.
- D. Complete a 20 to 30-minute operational ground check. Refer to the aircraft POH.
- E. Remove the oil filter and oil filter element.
- F. Examine the oil filter, if the quantity of metallic particles has increased, send the metallic particles for analysis and proceed to Corrective Action 5 in Table 4. If there are no metallic particles, continue with routine engine operation and maintenance.

If 10 or more metallic particles or flakes or slivers of metal are found on this screen:

- A. It is likely that the particles have bypassed the oil filter and have circulated to other parts of the engine.
- B. In this case, the particles could now be in the close-tolerance gaps between the crankshaft main bearings and crankshaft. The crankshaft could be scored or have heat damage due to decreased oil flow.
- C. **Do not continue further flight.**
- D. Proceed to Corrective Action 4 in Table 4.

12-30 - FAULT ISOLATION

1. Recommended Approach to Fault Isolation

The Field Service Tool (FST) is a diagnostic software tool loaded on a digital display device (computer laptop, Notebook, etc. running Microsoft® Windows 7, 8.1, or 10) that interfaces with the engine using the iE² Service Cable (ST-528) and the iE² Field Service Tool CAN Interface (ST-530). As the EECS components and the Engine Control Unit (ECU) monitor and control engine operation. The optional Data Logger (if installed) continuously collects data.

When connected to the ECU the FST can:

- Display fault codes (referenced in the Troubleshooting Guide in Appendix D)
- Clear fault codes
- Display real time engine data
- Download Data Logger data

The data history can show trends to further help with engine diagnostics. The FST is to be used only during servicing and maintenance and NOT during flight.

⚠ CAUTION TO ENSURE CORRECT EECS OPERATION, DO NOT USE THE FST DURING FLIGHT.

A. Additional Fault Isolation Guidelines

- (1) In addition to the FST, the Fault Isolation Guide in Table 1 shows the specific problems, causes, and corrections. Continue from the simplest to the most complex possible causes and corrections.
- (2) Review maintenance logs to identify trends and possible causes.
- (3) Discuss operational problems with the pilot to identify background, details, or incidents of unusual operation.
- (4) The "Ref." column in Table 1 contains references to the following:
 - (a) A lone numeric entry such as "72-00" refers to a chapter in this manual.
 - (b) IOM refers to the *TEO-540-A1A Engine Installation and Operation Manual*.
 - (c) AMM refers to the *Airframe Manufacturer's Manual*.
 - (d) POH refer to the *Pilot's Operating Handbook*.

B. Record all findings and corrective action.

Table 1
Fault Isolation Guide

Problem	Cause	Corrective Action	Ref.
Engine will not start or starts with difficulty	Discharged battery	Replace with a charged battery.	AMM
	Incorrect starting procedure	Obey starting procedures or the Pilot's Operating Handbook.	IOM & POH
	Power control open too far	Set power control all the way aft.	
	Faulty starter	Complete the "Starter Replacement" procedure.	72-70

**Table 1 (Cont.)
Fault Isolation Guide**

Problem	Cause	Corrective Action	Ref.
Engine will not start or starts with difficulty (Cont.)	No fuel or low fuel level	Complete a check of the fuel supply. Service as required.	AMM
	No fuel flow Blockage in fuel hose	1. Disconnect the aircraft fuel supply hose to the fuel pump. 2. Complete a check of the fuel flow. 3. Examine for evidence of leaks and correct as required. 4. Clean the filters, strainers, lines, or fuel valves.	AMM
	Water in fuel system	Drain the fuel hoses.	AMM
	Cylinder compression problem	1. Complete the cylinder compression check. 2. Complete the "Cylinder Borescope Inspection" of cylinder(s) to determine if further disassembly and repairs are necessary.	72-30
	Damaged spark plug	Spark Plug Removal Ignition Lead Inspection Spark Plug Inspection Spark Plug Cleaning Spark Plug Gap Setting Spark Plug Rotation Spark Plug Installation	74-20 & 05-30
	Damaged or worn ignition lead	Ignition Lead Removal Ignition Lead Inspection Ignition Lead Installation	74-20
	Break in harness continuity	1. Visually examine the EECS harness for breaks and cracks. Refer to the "Wiring Inspection" section. 2. Remove and replace the harness as necessary.	72-70

**Table 1 (Cont.)
Fault Isolation Guide**

Problem	Cause	Corrective Action	Ref.
Engine will not start or starts with difficulty (Cont.)	Ignition system problem	1. Visually examine the harness for physical damage.	74-20
		2. Examine ignition leads for continuity using a high-tension lead tester.	
		3. Replace worn or damaged components as necessary.	
		4. Complete the following procedures: <ul style="list-style-type: none"> • Spark Plug Removal • Ignition Lead Inspection • Spark Plug Inspection 	
		• Spark Plug Cleaning	05-30
		• Spark Plug Gap Setting • Spark Plug Rotation • Spark Plug Installation	74-20
	Low cylinder compression	1. Complete the “Cylinder Compression Check Procedure.” 2. Complete a “Cylinder Borescope Inspection” procedure on low-pressure cylinder(s).	72-30
	Blocked fuel injector	1. Identify whether the cylinder with the suspected blocked fuel injector is cold or hot. (The cylinder will be cold after 2 minutes of engine operation.) 2. Complete the “Fuel Injector Removal” procedure. 3. Complete the “Fuel Injector Installation” procedure.*	73-10
* Review any applicable warranty information relative to replacement of a fuel component as per the latest revision of Service Letters L221 and L253.			

**Table 1 (Cont.)
Fault Isolation Guide**

Problem	Cause	Corrective Action	Ref.
Engine will not start or starts with difficulty (Cont.)	Leak in induction system	Complete the “Induction System Inspection” procedure.	72-80
	Internal fuel injector leak	Complete the “Fuel Injector Leak Check” procedure.”	73-10
	Fuel vaporizing in lines and fuel injector rail assembly Found only as follows: <ul style="list-style-type: none"> • High ambient temperatures • Engine operating for a long time at low or idle rpm 	<ol style="list-style-type: none"> 1. Operate with cowl flaps in the FULL OPEN position. 2. Keep ground operation to a minimum. 3. Operate with boost pump ON as necessary. 4. Complete a check of the vent return line for blockage. Clean if necessary. 	
	Low fuel pressure	<ol style="list-style-type: none"> 1. Look for a blocked fuel pump filter and inoperative NTO light. 2. Replace fuel pump or fuel pressure regulator. 	73-10
	Loose ignition leads	Make sure all ignition leads are secure.	74-20
	Damaged or worn ignition lead	Ignition Lead Removal Ignition Lead Inspection Ignition Lead Installation	74-20
	Engine to airframe ground strap not connected or broken	Clean terminals. Reconnect ground strap and preform a continuity check.	AMM
	Battery negative cable loose or faulty connection to airframe	Ensure battery cables are properly connected and tight. Preform a continuity check.	AMM

**Table 1 (Cont.)
Fault Isolation Guide**

Problem	Cause	Corrective Action	Ref.
Rough Idle	Fault in the ignition system	<ol style="list-style-type: none"> 1. Visually examine the harness for physical damage. 2. Examine leads using a high-tension lead tester. 3. Replace worn or damaged components as necessary. 4. Complete the following procedures: <ul style="list-style-type: none"> • Spark Plug Removal • Ignition Lead Inspection • Spark Plug Inspection • Spark Plug Cleaning • Spark Plug Gap Setting • Spark Plug Rotation • Spark Plug Installation 	74-20 & 05-30
	Uneven cylinder compression	<ol style="list-style-type: none"> 1. Complete the cylinder compression check. 2. Complete a borescope inspection of low-pressure cylinder(s). 	72-30
	Engine to airframe ground strap not connected or broken	Clean terminals. Reconnect ground strap and perform a continuity check.	AMM
	Battery negative cable loose or faulty connection to airframe	Ensure battery cables are properly connected and tight. Perform a continuity check.	AMM
	Discharged battery or weak charging system	Replace with a charged battery. Test charging system	AMM
Engine will not idle unless the boost pump is on	Low fuel pressure	<ol style="list-style-type: none"> 1. Complete a check for a blocked fuel pump filter and an inoperative NTO light. 2. Replace the fuel pump or fuel pressure regulator. 	73-10

**Table 1 (Cont.)
Fault Isolation Guide**

Problem	Cause	Corrective Action	Ref.
Engine will not idle unless the boost pump is on (Cont.)	Fuel vaporizing in lines	1. Operate with cowl flaps in the FULL OPEN position and keep ground operation to a minimum. 2. Operate with boost pump on as necessary. 3. Complete a check of the vent return line for blockage. Clean if necessary.	
	Broken fuel pump drive	Replace the fuel pump per the "Fuel Pump Replacement" procedure.	73-10
Low fuel pressure in the fuel injector rail assemblies and fuel pump	O-ring is not installed and/or intact	All O-rings on the fuel pressure regulator must be installed.	73-10
Engine will not shut off	Faulty power switches	Replace the switches.	AMM
	Faulty wiring in a harness	Replace the harness.	72-70
	Ignition switch faulty	Complete a check for faults on the ignition switch circuits. Repair as necessary.	AMM
	Faulty ECU	Replace the ECU.	72-70
Low fuel flow	Dirty fuel pump filter	Either remove and clean the fuel pump filter with acetone or MEK. Blow out with compressed air and re-install the fuel pump filter or replace the fuel pump filter as per the "Fuel Pump Filter Inspection" procedure.	73-10

**Table 1 (Cont.)
Fault Isolation Guide**

Problem	Cause	Corrective Action	Ref.
Low fuel flow (Cont.)	Faulty fuel flow gage	<ol style="list-style-type: none"> 1. Install the master fuel flow gage. 2. Operate the engine to compare the gages. 3. Replace the faulty fuel flow. 	AMM
	Low fuel pressure	<ol style="list-style-type: none"> 1. Complete a check for a blocked fuel pump filter. 2. Replace the fuel gage or replace fuel pressure regulator. Refer to the "Fuel Pressure Regulator Replacement" procedure. 	73-10
Engine will not turn static rpm or will not develop rated rpm	Decreased air flow in the air reduction system	<ol style="list-style-type: none"> 1. Complete the "Induction System Inspection" and remove all blockages. 2. Make sure that the air box is installed in accordance with the airframe manufacturer's specifications. 	72-80 & AMM
	Propeller is out of adjustment (not reaching low pitch)	Adjust the propeller in accordance with airframe or propeller manufacturer's instructions.	AMM
	Muffler's internal baffles are broken and blocking the exhaust outlet NOTICE: Broken baffles can move around freely in the muffler. The engine could turn static rpm's intermittently.	Examine the baffles	AMM

**Table 1 (Cont.)
Fault Isolation Guide**

Problem	Cause	Corrective Action	Ref.
Engine will not turn static rpm or will not develop rated rpm (Cont.)	Air filter dirty	Replace the air filter. NOTICE: Occasionally new air filters will have an excessive air drop through them. If this condition is suspected, remove the air filter and operate the engine to full power on a hard surface in a dust-free area.	AMM
	Too much air dropped through a new air filter Defective air filter	<ol style="list-style-type: none"> 1. Put the aircraft in a dust-free area. 2. Remove the air filter. 3. Operate the engine to full power control. 4. If the engine operates at full rpm, replace the air filter with a new air filter. 	AMM
	Fouled spark plugs	<ul style="list-style-type: none"> • Spark Plug Removal • Spark Plug Cleaning • Spark Plug Fouling • Spark Plug Gap Setting • Spark Plug Rotation • Spark Plug Installation 	74-20 & 05-30
	Incorrect fuel flow	<ol style="list-style-type: none"> 1. Complete a check on the EECS for correct sensor readings. 2. Replace the sensors or replace the ECU. 	72-70
		<ol style="list-style-type: none"> 3. Look for blocked fuel pump filters. Clean or replace the fuel pump filter. 	73-10
Blockage in air inlet or manifold	<ol style="list-style-type: none"> 1. Make sure that the air filters are clean. 2. Complete the “Induction System Inspection” 3. Repair or replace the air inlet or manifold if necessary. 	72-80	

**Table 1 (Cont.)
Fault Isolation Guide**

Problem	Cause	Corrective Action	Ref.
Engine will not turn static rpm or will not develop rated rpm (Cont.)	Incorrect type of fuel	Refer to the section "Incorrect Fuel or Fuel Contamination."	05-50
	Power control lever is incorrectly adjusted	Adjust the power control lever in accordance with airframe manufacturer's instructions.	
	Insufficient combustion	1. Complete a cylinder compression check. 2. Complete a borescope inspection to look for excessive wear on the cylinders or damaged valve and valve seats.	72-30
		3. Complete a top overhaul (replace all of the engine cylinders).	72-30
Engine will not supply the rated power	Blockage in manifold system	Clear all ducting.	
	Blockage in compressor impeller or turbine	Replace the turbocharger.	72-40
	Compressor is too dirty	1. Thoroughly clean the compressor assembly. 2. Service the air cleaner and do a check for leakage.	72-40
	Leak in engine intake or exhaust	Tighten loose connections or replace manifold gaskets as necessary.	
	Rotating assembly bearing seizure	Replace the turbocharger.	72-40
	Blockage in return lines from actuator to exhaust bypass valve controller	Remove and clean the return lines.	
	EECS not receiving signal for full power	1. Complete a check for faults with the EECS. 2. Replace components as necessary.	72-70

**Table 1 (Cont.)
Fault Isolation Guide**

Problem	Cause	Corrective Action	Ref.
Engine will not supply the rated power (Cont.)	Oil pressure too low	1. Tighten fittings. 2. Replace oil hoses. 3. Increase oil pressure as necessary.	72-50
	Inlet orifice to actuator is clogged.	Remove the inlet line at the actuator and clean the orifice.	
	Malfunction of exhaust bypass control valve	Replace the exhaust bypass control valve.	
	Exhaust bypass valve butterfly is not closing	1. Examine orifice inlet to actuator for blockage. 2. Clean as necessary. 3. Examine the butterfly shaft for binding.	
	Turbocharger impeller binding, frozen or fouling housing	1. Examine the shaft play and contact with housings for binding. 2. If contact is present, replace the turbocharger.	72-40
	Piston seal in actuator is leaking NOTICE: Usually accompanied by oil leakage at drain line.	Remove and replace the actuator or disassemble and replace the packing.	
	Fuel injector clogged	Replace the clogged fuel injector.	73-10
Engine smokes excessively NOTICE: An engine regularly smokes if it is idling for an extended period.	Air in oil hoses or actuator	Bleed the system.	
	Breather is clogged	Make sure that nothing is blocking the air flow.	
	Exhaust bypass valve is not opening correctly	Examine the exhaust bypass valve to make sure that the shut off valve in the return line is operating correctly.	
Engine hesitates, misses	Valve sticking	Refer to "Corrective Action for Valve Sticking."	72-30 & 05-50

**Table 1 (Cont.)
Fault Isolation Guide**

Problem	Cause	Corrective Action	Ref.
Engine surges	Fuel injectors are dirty	Replace the fuel injector.	73-10
	Low engine oil level	Complete a check of the oil level. Add oil. Refer to the sections "Oil Level Check" and "Add Oil to the Engine."	12-10
	Malfunctioning propeller governor	Remove the propeller governor. Either send it to a manufacturer-approved repair facility or replace it as per the "Propeller Governor Replacement" procedure.	72-20 & AMM
	Incorrect propeller governor	Make sure that the propeller governor is the correct part number.	
	Breather is blocked	Examine the breather for obstructions. Remove all obstructions.	
	Faulty oil pump	Replace the oil pump per the "Oil Pump Removal" and "Oil Pump Installation" procedures.	72-25
	Propeller blades are intermittently sticking in hub	Remove and overhaul the propeller as per the propeller manufacturer's instructions.	
	Front main bearing has too much clearance	Complete a "Propeller Oil Control Leak Test".	72-25
Irregular oil pressure	Oil pump is sucking air	Replace the oil pump per the "Oil Pump Removal" and "Oil Pump Installation" procedures.	72-25
Low oil pressure	Oil not of the correct viscosity for ambient temperature	Make sure oil of the correct viscosity for the ambient temperature is used.	IOM Appendix A
	Low engine oil level	Complete a check of the oil level. Add oil. Refer to the sections "Oil Level Check" and "Add Oil to the Engine."	12-10

**Table 1 (Cont.)
Fault Isolation Guide**

Problem	Cause	Corrective Action	Ref.
Low oil pressure (Cont.)	High oil temperature	Examine the engine for these conditions: 1. Low oil level. Complete the "Oil Level Check" procedure.	12-10
		2. Incorrect grade/weight of oil Refer to Appendix A.	IOM
		3. Oil cooler bypass valve seating and operation	72-50
		4. Partial or full blockage in oil cooler lines 5. High cylinder head temperature 6. Excess blow-by 7. Blockage in air duct to the oil cooler.	AMM
	Pressure relief valve is out of adjustment	Per the "Oil Pressure Adjustment" procedure, turn the adjusting screw (on the oil pressure relief valve) to adjust oil pressure or change the spring as necessary in the oil pressure relief valve.	72-50
	Dirt or metal chips under the oil pressure relief valve	1. Remove, disassemble, and clean (remove dirt or metal chips) the oil pressure relief valve.	72-50
		2. Complete the "Oil Change Procedure."	12-10
		3. Complete a "Cylinder Compression Check Procedure."	72-30
	Blockage at inlet side of oil pump	Remove and clean the oil suction screen and oil passage on the inlet side of the oil pump. Refer to the section "Oil Suction Screen Removal/ Inspection/Cleaning/ Installation."	12-10

**Table 1 (Cont.)
Fault Isolation Guide**

Problem	Cause	Corrective Action	Ref.	
Low oil pressure (Cont.)	Damaged oil pressure relief valve seat	Either replace the oil pressure relief valve or Replace the valve seat per the latest revision of Service Instruction No. SI-1172 for instructions.	72-50	
	Excess internal oil leakage	Look for: <ul style="list-style-type: none"> • Loose or missing plugs in oil galley • Piston cooling nozzles to lock open during idle rpm • Too much bearing clearance • Cracks in the oil galley area of the crankcase 		
	Air leak on suction side of the oil pump		1. Examine the conditions of these components: <ul style="list-style-type: none"> • Oil suction screen gasket 	12-10
			<ul style="list-style-type: none"> • Oil sump gasket 	72-50
			<ul style="list-style-type: none"> • Oil pump mating surface to accessory housing 	72-25
	2. Replace cracked or damaged parts.			
Relocated oil pressure take-off	Use only the approved oil pressure take-off point. NOTICE: If the oil pressure take-off point on the engine has moved closer to the oil pump, discharge it, and then the oil pressure will rise.			
Failed or failing bearings	Metal in the oil filter element or oil suction screen could be a sign of excessive bearing wear. Complete an oil change. Send the engine to Lycoming Engines for evaluation. Include a description of the problem.	12-10		

**Table 1 (Cont.)
Fault Isolation Guide**

Problem	Cause	Corrective Action	Ref.
Excessive oil consumption	New piston rings are not completely seated (break-in not done)	As part of break-in, operate the engine at not less than 65% power for the first 50 hours to seat new piston rings.	IOM
	Piston rings are worn or incorrectly installed OR Cylinder barrels are glazed or worn too much	1. Complete the “Cylinder Compression Check Procedure.” 2. Complete the “Cylinder Borescope Inspection” procedure to determine if further corrective action is necessary NOTICE: Listen for a hissing sound at the breather entrance of the crankcase which is an indication of air leaks around the rings.	72-30
		3. Remove the cylinders, replace the piston rings, deglaze the cylinder barrels, and re-install the cylinders as per the following sections: <ul style="list-style-type: none"> • Cylinder Removal • Piston Removal • Piston Inspection • Piston Ring Replacement • Barrel Glaze and Varnish Removal from Interior Cylinder Barrel • Piston Installation • Cylinder Installation 	72-30
	Worn valve guides	1. Measure the valve guides for wear as per instructions in the section “Exhaust Valve and Guide Inspection.” 2. Replace worn valve guides.	72-30
	Oil leaks	Examine the external area of the engine for leaks, identify and correct the cause of any leak.	

**Table 1 (Cont.)
Fault Isolation Guide**

Problem	Cause	Corrective Action	Ref.
Excessive oil consumption (Cont.)	Oil siphoned from engine during flight	<ol style="list-style-type: none"> 1. Verify that the oil level gage (dipstick) is secure and the oil access door closes correctly. 2. Make sure that the breather hose is accurately cut and installed to prevent siphoning. 	12-10
	Oil level too high	Do not fill above the maximum oil sump capacity.	IOM Appendix A
		Drain some oil (start of "Oil Change Procedure.")	12-10
	Breather blocked or restricted.	Clear breather hose blockage or restriction.	AMM
	Cam spacer not installed.	Borescope breather tube in accessory housing to ensure cam spacer is installed.	72-20
High oil temperature	Cooling baffles are missing, broken, or incorrectly installed	<p>Ensure that all baffles are installed correctly, and none are broken. Replace as necessary.</p> <p>NOTICE: Never modify, relocate, or eliminate any cooling baffles.</p>	
	Oil level is too low	Complete the "Oil Level Check" at regular intervals. Complete the "Add Oil to the Engine" procedure as necessary. Keep oil at the specified level.	12-10
	Incorrect grade of oil	Use the correct grade of oil per the latest revision of Service Instruction No. SI-1014.	
	Oil cooler bypass valve is not operating correctly or seating accurately	Replace the oil cooler bypass valve. Refer to the latest revision of Service Instruction No. SI-1316.	72-50

**Table 1 (Cont.)
Fault Isolation Guide**

Problem	Cause	Corrective Action	Ref.
High oil temperature (Cont.)	Leaks in engine induction system	Identify and correct the cause of all leaks.	72-80 & AMM
	Oil cooler or oil cooler lines are fully or partially blocked	1. Remove the oil cooler and oil cooler lines. 2. Clean and service the oil cooler.	AMM
	Too much cylinder blow-by	Complete a “Cylinder Compression Check Procedure.”	72-30
	Defective oil temperature gage	1. Install the master temperature gage and operate the engine to compare gages. 2. Replace the faulty gage if necessary.	AMM
High manifold pressure at idle	Air leak in induction system	Complete the “Induction System Inspection.” Identify and correct the cause of all leaks. NOTICE: If the induction system has leaks, the engine will idle rough.	72-80 & AMM
	Incorrect tappets or hydraulic lifters were installed	Send the engine to Lycoming Engines for evaluation.	
High oil pressure	Relocated oil pressure take-off point on the engine	Use only the approved oil pressure take-off point.	
	Oil temperature is too cold	Before increasing the throttle, allow the oil temperature to increase.	
	Oil pressure incorrectly adjusted	Decrease the oil pressure by turning the pressure adjustment on the oil pressure relief valve counterclockwise per the “Oil Pressure Adjustment” procedure.	72-50

**Table 1 (Cont.)
Fault Isolation Guide**

Problem	Cause	Corrective Action	Ref.
High oil pressure (Cont.)	Incorrect weight of oil used	Use the recommended viscosity of oil for the ambient temperature.	IOM Appendix A
	Oil passage is blocked from the pressure relief valve to the sump	<ol style="list-style-type: none"> 1. Remove the pressure relief valve from the engine. 2. Push a soft copper wire through the oil passage to the oil sump to remove blockage. <p>NOTICE: If blockage continues, remove the oil sump and clean the passage.</p>	72-50
	Relocated oil pressure take-off point on the engine	Use only the approved oil pressure take-off point.	
	Oil temperature is too cold	Before increasing the power control, allow the oil temperature to increase.	
	Oil pressure incorrectly adjusted	Decrease the oil pressure by turning the pressure adjustment on the oil pressure relief valve counterclockwise per the “Oil Pressure Adjustment” procedure.	72-50
	Incorrect weight of oil used	Use the recommended viscosity of oil for the ambient temperature per the latest revision of Service Instruction No. SI-1014.	
	Oil passage is blocked from the pressure relief valve to the sump	<ol style="list-style-type: none"> 1. Remove the pressure relief valve from the engine. 2. Push a soft copper wire through the oil passage to the oil sump to remove blockage. <p>NOTICE: If blockage continues, remove the oil sump and clean the passage.</p> <ol style="list-style-type: none"> 3. Reinstall the oil pressure relief valve. 	72-50

**Table 1 (Cont.)
Fault Isolation Guide**

Problem	Cause	Corrective Action	Ref.
Critical altitude is lower than specified	Exhaust bypass control valve is not getting enough oil pressure to close the exhaust bypass valve actuator	Examine these components for leaks or obstructions: <ul style="list-style-type: none"> • Pump outlet pressure • Oil filters • External lines 	
	Exhaust bypass control valve is not correctly operating	Replace the exhaust bypass valve.	72-40
	Metering jet in actuator is blocked	Remove the actuator and the clean the jet.	
	Exhaust bypass valve actuator piston seal is leaking and cannot be serviced	<ol style="list-style-type: none"> 1. Examine the actuator drain for leaks. 2. Clean the cylinder and replace the piston seal. 	
	Leak in exhaust system	Identify and correct the cause of the leak.	
	Damaged compressor impeller blades	Replace the turbocharger.	72-40
High deck pressure (Compressor discharge pressure)	Exhaust bypass valve is not opening correctly	Examine the exhaust bypass valve to make sure that the shut off valve in the return line is operating correctly.	78-00
		Examine the butterfly shaft for binding.	
		Replace the exhaust bypass valve or correct linkage binding.	
	Oil pressure is too high	<ol style="list-style-type: none"> 1. Make sure that the pressure is correct at the exhaust bypass actuator inlet. 2. If the pressure on the outlet side of the actuator is too high, make sure that the turbocharger control valve is operating correctly. 	
Exhaust bypass valve is not operating correctly	Replace the exhaust bypass valve.	72-40	

**Table 1 (Cont.)
Fault Isolation Guide**

Problem	Cause	Corrective Action	Ref.
Sluggish propeller operation	Propeller oil control leak.	Complete the "Propeller Oil Control Leak Test Procedure".	72-20
	Clogged or restricted propeller governor oil passage	Check propeller governor gasket screen for blockage or restriction.	12-10
Engine does not hold rpm during cruise, climb, or descent	Propeller oil control leak	Complete the "Propeller Oil Control Leak Test Procedure."	72-20
	Clogged or restricted propeller governor oil passage	Check propeller governor gasket screen for blockage or restriction.	12-10
Propeller goes into feather during landing rollout with decreased power setting	Propeller oil control leak	Complete the "Propeller Oil Control Leak Test Procedure."	72-20
	Clogged or restricted propeller governor oil passage	Check propeller governor gasket screen for blockage or restriction.	12-10
Excessive engine vibration	Cracked engine mounts or defective mount bushings	Replace the engine mounts or bushings.	AMM
	Engine mount bushing incorrectly installed	Check for damage and install the engine mount bushing correctly.	AMM


NOTICE: An NTO indication only can be cleared once the fault is corrected. After the fault is corrected, cycling power will turn off the NTO indication.

This page intentionally left blank.

72-00 - ENGINE REMOVAL AND RETURN TO SERVICE

NOTICE: Instructions in this chapter are general guidelines for engine removal and return to service. Refer to the aircraft manual for instructions specific to each application.

1. Engine Removal Prerequisites

 WARNING: DURING ALL MAINTENANCE PROCEDURES AND INSPECTIONS, ENSURE THAT THE ENGINE IGNITION SWITCH IS IN THE “OFF” POSITION, ALL POWER TO THE AIRCRAFT IS DISCONNECTED, AND ALL PERSONNEL ARE CLEAR OF THE PROPELLER’S ROTATIONAL ARC.

A. Before engine removal from the aircraft:

NOTICE: If the engine is to be stored or sent to the factory for service or overhaul, complete the engine preservation procedure before engine removal. Refer to instructions in the “Engine Preservation and Storage” chapter in the *TEO-540-A1A Engine Installation and Operation Manual*.

- (1) Complete the engine preservation procedure, as necessary.
- (2) Make sure that all electrical switches, circuit breakers, Ignition Switch, and the Fuel Selector Valve are in the OFF position.
- (3) Pull the circuit breaker to discharge power to the EECS/ECU.
- (4) In accordance with the aircraft manufacturer’s instructions, remove all cowling, baffling and nacelle access panels to enable engine removal.
- (5) Disconnect the ground terminal of the battery.
- (6) Disconnect the positive terminal of the battery.
- (7) Disconnect and examine the leads and wiring for damage or frayed wiring. Replace damaged or frayed wiring per aircraft manufacturer’s instructions.
- (8) Remove all engine accessories, aircraft components, or aircraft component connections as necessary for engine removal.
- (9) If not already done to prepare the engine for storage or shipping, drain oil from engine. Refer to the “Oil Change Procedure” in Chapter 12-10.
- (10) Remove the propeller in accordance with the aircraft manufacturer’s instructions and/or propeller manufacturer’s instructions.

2. Engine Removal Procedure

NOTICE: If the engine is to be returned to the factory for servicing, the engine wiring harness, ECU, and FADEC must be disconnected and removed from the airframe and returned with the engine.

Refer to Table 2 - Wiring Harness Connector Guidelines in Chapter 72-70 when disconnecting the wiring harness to avoid damage to the connectors.

A. Remove the engine as follows:

- (1) Complete the prerequisites in the section “Engine Removal Prerequisites” in this chapter.
- (2) During removal of engine parts, look for indications of scoring, burning or other unacceptable conditions of the wire harness, hoses and related parts.
- (3) Disconnect all connecting control cables.

⚠ CAUTION USE CARE TO PREVENT DUST, DIRT, SAFETY WIRE, SAFETY CABLE, NUTS, WASHERS OR OTHER FOREIGN MATTER FROM ENTERING THE ENGINE. DURING ENGINE REMOVAL, IF ITEMS ACCIDENTALLY FALL INTO THE ENGINE, STOP WORK, FIND AND REMOVE ALL OF THE DROPPED ARTICLES. USE CORRECT PLUGS, CAPS, AND OTHER COVERINGS TO COVER EXPOSED OPENINGS. INSTALL DUST CAPS OVER, NOT IN, TUBE ENDS. DO NOT PUT TAPE OR PLUGS INSIDE OPEN LINES OR FITTINGS.

- (4) Apply a cap over oil and fuel hoses and connections to prevent spillage and debris from entering the engine.
- (5) Apply tags to identify ports, clips, tubes, wires, etc. for reference to make correct connections during engine installation. Identify the location of each part during removal. Attach a tag to unserviceable parts and units for examination or replacement.
- (6) Disconnect both alternators from the engine.

⚠ CAUTION USE CAUTION WHEN TOUCHING THE WIRING HARNESS, SENSORS AND ACTUATORS. THEY CAN BE EASILY DAMAGED. NONE CAN BE REPAIRED. IF ANY OF THESE ITEMS ARE DAMAGED, THEY MUST BE REPLACED. IF ONE WIRE BREAKS ON THE WIRING HARNESS, THE COMPLETE HARNESS WILL NEED TO BE REPLACED.

- (7) Disconnect the airframe interface wiring harness from the ECU and power box. Refer to the airframe manufacturer's wiring diagram.
- (8) Disconnect the engine-to-firewall wiring harness from the airframe interface wiring harness at the four firewall connectors (FW1-P1, FW1-P2, FW2-P1, FW2-P2). Matching connections are identified on both wiring harnesses.
- (9) Disconnect and tag the engine wiring bundles and other connections from the following components in accordance with the airframe manufacturer's instructions.
 - The ECU components
 - Miscellaneous airframe accessories and instrument connections
 - All engine and EECS airframe grounds.
- (10) Install protective caps on all electrical connectors.
- (11) Disconnect the power control in accordance with the airframe manufacturer's instructions.
- (12) Remove all wiring bundle attaching clamps and hardware.
- (13) Remove the manifold pressure gage line and aircraft fuel supply lines in accordance with the aircraft manufacturer's instructions.
- (14) Refer to the aircraft manufacturer's instructions to disconnect any accessory connection or to remove any external accessories to enable removal of the engine from the aircraft.
- (15) Make sure that all wires, lines, and attachments between the engine and airframe are disconnected and capped.

- (16) Attach an engine-lifting cable (with a minimum capacity of 750 lb. (340 kg)) to the lifting straps on the engine in accordance with Figure 1.

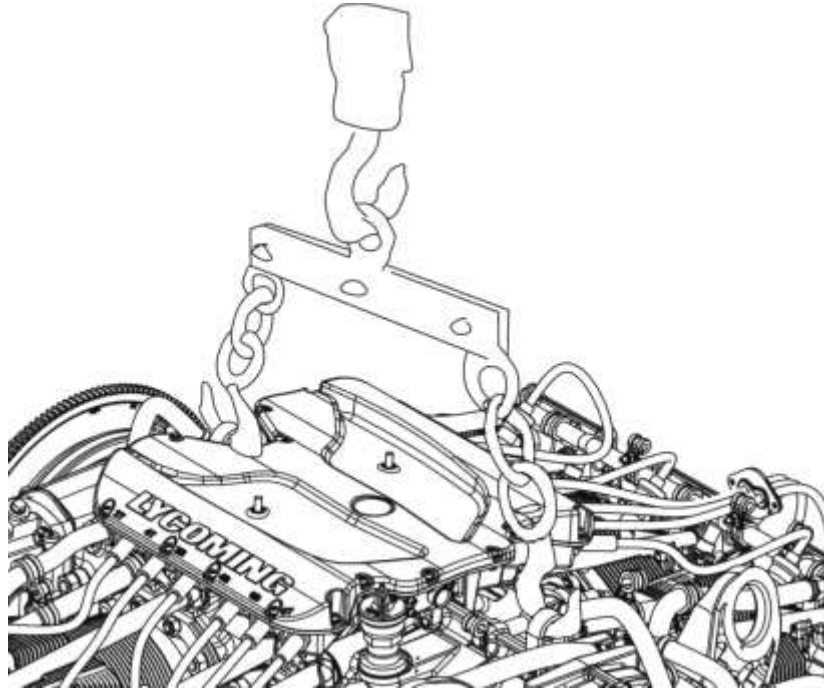


Figure 1
Lifting Straps

- (17) Use a crane or overhead hoist (with a minimum load of 750 lb. (340 kg)) to take up slack on the lifting cable until there is enough tension to hold the weight of the engine.
- (18) Remove the nuts and bolts from the engine mounts that are supplied by the airframe manufacturer.

⚠ CAUTION MAKE SURE THE AREA IS CLEAR WHEN LIFTING THE ENGINE. DO NOT ALLOW THE FRONT, REAR, SIDES OR BOTTOM OF THE ENGINE TO BUMP OR STRIKE ANY OBJECTS TO PREVENT DAMAGE TO THE ENGINE OR ITS COMPONENTS.


- (19) Carefully lift the engine slowly out of the airframe.
- (20) Put the engine on an engine stand, transport dolly, or engine shipping container base.

⚠ CAUTION DO NOT PUT TAPE OR INSERT PLUGS INSIDE OPEN LINES OR FITTINGS.

3. Engine Installation Preparation Requirements

To prevent delays on engine re-installation, have the following materials and new spare parts available (refer to the *TEO-540-A1A Illustrated Parts Catalog*) identified in Table 1. Follow the procedures in Table 1 to prepare the engine for installation (if the engine was not in storage). If the engine was in storage, refer to the *TEO-540-A1A Engine Installation & Operation Manual* for instructions to prepare the engine for installation.

Table 1
Materials and Procedures to Prepare a Serviced Engine for Installation

New gaskets, seals, O-rings, and packing (Make sure the new parts are not brittle, torn, cut, or cracked and do not have flashings, deterioration/wear or deformities.)*	Always install new gaskets, seals, O-rings, or packing.
 CAUTION ALWAYS INSTALL NEW SAFETY WIRE, NEW LOCK WASHERS, NEW LOCK NUTS, NEW TAB WASHERS, AND NEW COTTER PINS.	
New safety cable, safety wire, lock nuts, lock washers, tab washers, and cotter pins	
New replacement part for any part that had to be discarded*	
Oil per specifications in Appendix A of the <i>TEO-540-A1A Engine Installation and Operation Manual</i>	“Add Oil to the Engine” in Chapter 12-10
Cleaning solvents and lint-free wipes (identified in Chapter 05-30)	Cleaning procedures in Chapter 05-30
*Refer to the latest revision of Service Bulletin No. SB-240 to identify parts that must be replaced when removed. Before installing a component, complete a check of the shelf-life of the part as per the latest revision of Service Letter No. L247	

After all inspections and maintenance tasks are complete, install the engine per the *TEO-540-A1A Engine Installation and Operation Manual*.

During engine re-installation:

- A. Refer to and follow the "Maintenance Practices" in Chapter 05-00.
- B. Replace any gaskets, seals or packing that were removed with new parts.
- C. Replace any part that was damaged or that could not be repaired with a new part.
- D. Install external accessories as per the aircraft manufacturer's instructions.
- E. Examine the engine mounts to make sure they are not damaged or bent.

4. Operational Ground Check

NOTICE: The purpose of this check is to make sure the installed engine operates in the aircraft according to specifications in Appendix A of the *TEO-540-A1A Engine Installation and Operation Manual*.

- A. Make sure that all of the engine gages operate correctly.
- B. Examine the No Take-Off (NTO) and Time Limited Operation (TLO) lamps, and ECU for active fault codes.
- C. Make sure that the vent and breather lines are correctly installed and secured in accordance with the aircraft manufacturer's instructions.

- D. Install the cowling and all of the aircraft baffles per the aircraft manufacturer's instructions.
- E. Put the aircraft in a position against the wind.
- F. Complete the applicable procedures in either the "Engine Initiation" chapter or "Engine Operation" chapter of the *TEO-540-A1A Engine Installation and Operation Manual*.

NOTICE: Engine initiation procedures are to be done in the field on any of the following newly installed Lycoming engines:

- Any new, rebuilt, or overhauled engine
 - Engine taken out of storage
5. Engine Mount Inspection
- A. Examine the engine mounts for cracks and looseness. Replace a cracked engine mount or tighten any loose hardware in accordance with the aircraft manufacturer's instructions.
 - B. Examine the rubber engine mounts and mounting hardware for signs of deterioration or damage. Replace worn or damaged engine mounts or hardware in accordance with the aircraft manufacturer's instructions.
 - C. Examine the four engine mounting brackets for cracks, damage, or visible signs of wear. Replace cracked, damaged, or worn engine mounting brackets.
 - D. After the first 100 hours of operation, make sure that the engine fastening nuts and bolts for the engine mounts are torqued correctly. For torque values, refer to the aircraft manufacturer's instructions.
6. Return to Service Procedure
- Before returning this engine to service;
- Make sure that you correct all problems and complete all of the necessary maintenance.
 - Complete the "Operational Ground Check" in this chapter.
 - Specifically monitor:
 - Power output (static and idle rpm)
 - Fuel and oil pressure
 - Cylinder and oil temperatures

This page intentionally left blank.

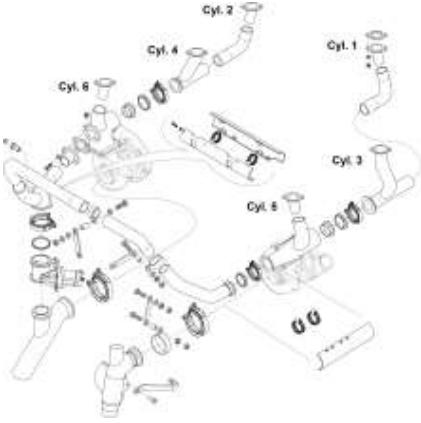
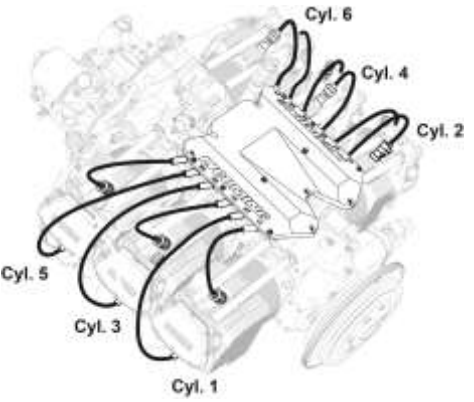
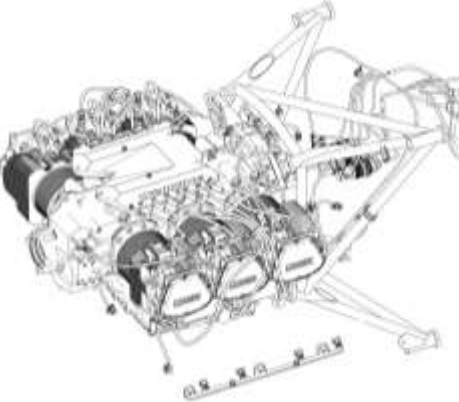
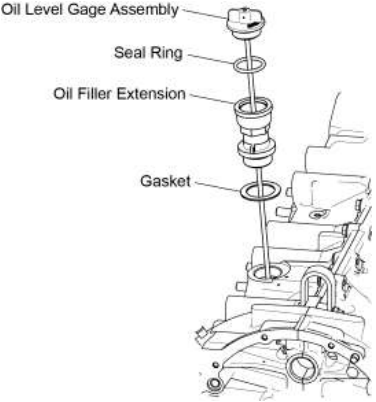
72-05- ENGINE DISASSEMBLY

Engine disassembly begins after the oil has been drained from the engine per instructions in Chapter 12-10 and the engine is removed from the airframe (per instructions in this manual and the applicable Airframe Maintenance Manual).

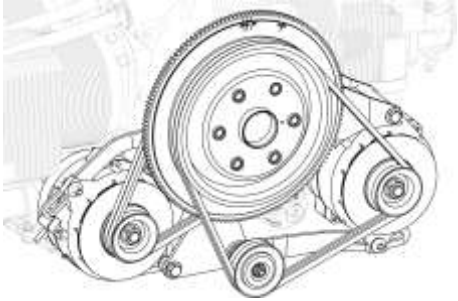

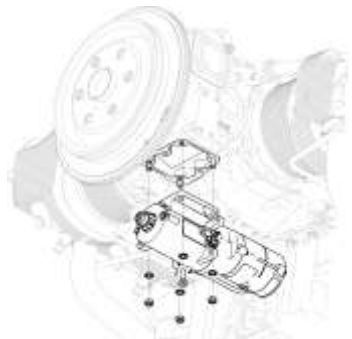
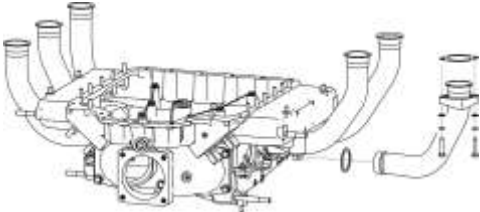
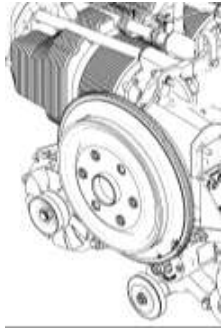
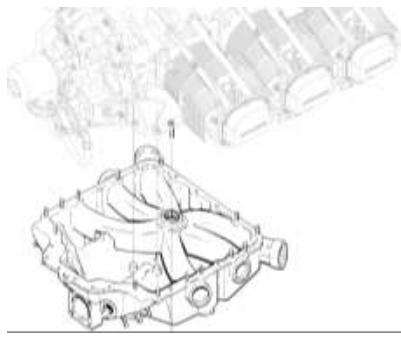
1. Engine Disassembly Procedure

Complete the procedures for engine disassembly for the TEO-540-A1A engines in the sequence identified in Table 1 - Sequence of Engine Disassembly Procedure.

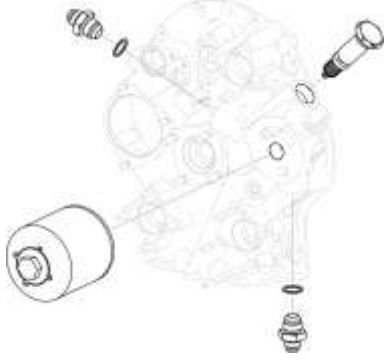
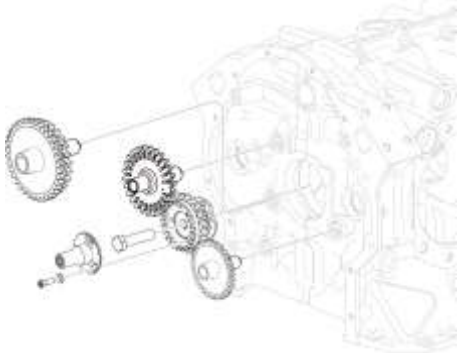
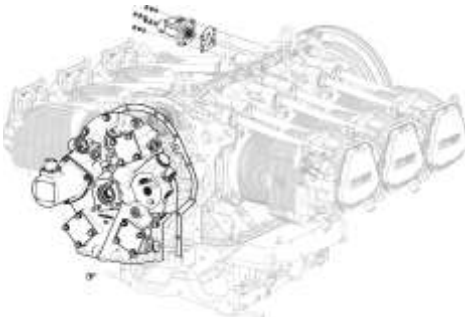
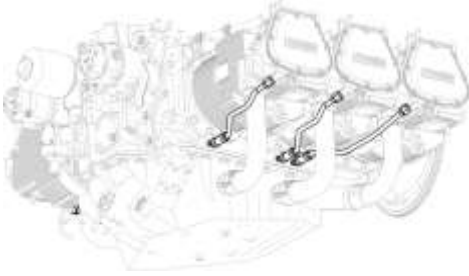
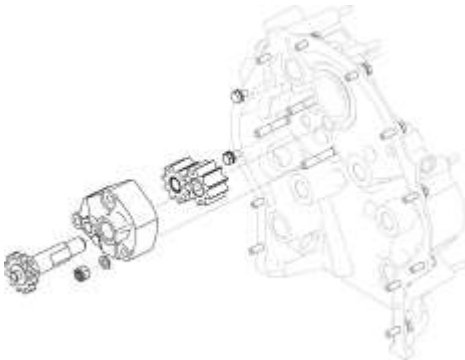

**Table 1
Sequence of Engine Disassembly Procedures**

Step	Reference	Step	Reference
<p>Step 1 Disconnect the wiring harness from the EGT and TIT sensor leads and secure the sensor leads, remove the exhaust system and turbocharger (Figure 1).</p>	<p>“Sensor Replacement Procedures” in Chapter 72-70 and “Exhaust System Removal” procedure in Chapter 78-00 and “Turbocharger Removal” in Chapter 72-40</p>  <p>Figure 1 Exhaust System</p>	<p>Step 3 Remove the ignition leads, coil box, and spark plugs (Figure 3).</p>	<p>Procedures in Chapters 74-20 and 74-30 in this manual</p>  <p>Figure 3 Ignition Leads, Coil Box, and Spark Plugs</p>
<p>Step 2 Disconnect the sensors and remove the wiring harness (Figure 2).</p>	<p>“Engine-to-Firewall Wiring Harness Removal” procedure in Chapter 72-70</p>  <p>Figure 2 Wiring Harness</p>	<p>Step 4 Remove the oil level gage assembly and oil filler extension (Figure 4).</p>	<p>“Oil Level Gage Assembly Removal” procedure in Chapter 72-50</p>  <p>Figure 4 Oil Level Gage</p>


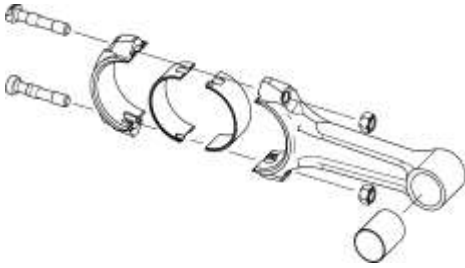
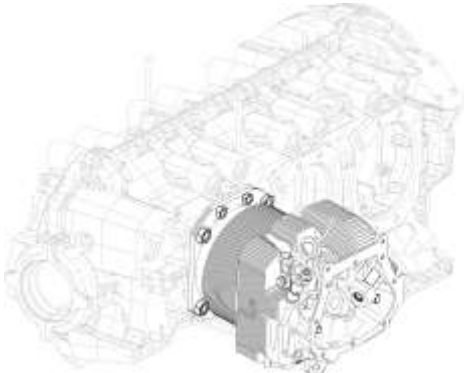
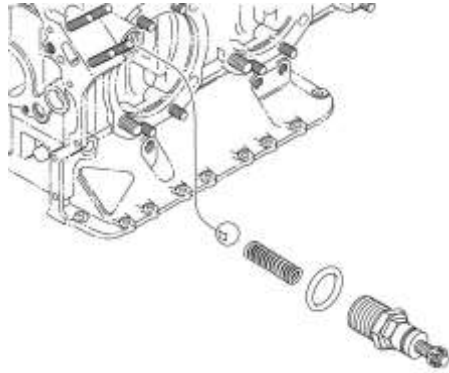
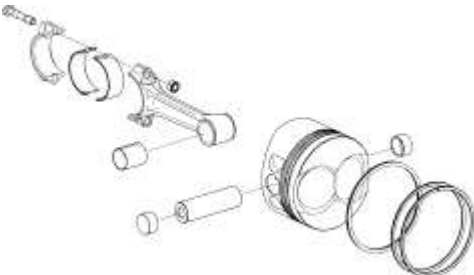
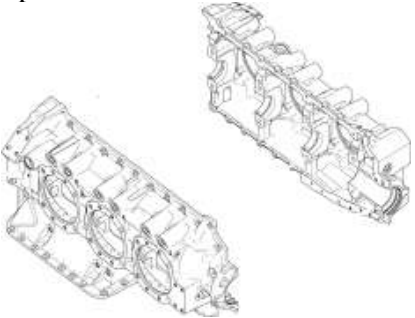
**Table 1 (Cont.)
Sequence of Engine Disassembly Procedures**

Step	Reference	Step	Reference
<p>Step 5 Remove the alternator belts, two alternators, and alternator brackets (Figure 5).</p>	<p>“Alternator Belt Removal” and “Alternator and Bracket Removal” procedures in Chapter 72-70</p>  <p>Figure 5 Alternator Bracket, Alternator, and Alternator Belt</p>	<p>Step 8 Remove the fuel hoses, throttle body, fuel injector rail assemblies, and fuel pump (Figure 8).</p>	<p>Procedures in Chapters 73-10 and 73-20</p> <ul style="list-style-type: none"> • Fuel Hose Removal • Throttle Body Removal • Fuel Injector Rail Assembly Removal • Fuel Pump Removal  <p>Figure 8 Fuel System Components</p>
<p>Step 6 Remove the starter (Figure 6).</p>	<p>“Starter Removal” procedure in Chapter 72-70</p>  <p>Figure 6 Starter</p>	<p>Step 9 Remove the intake pipes (Figure 9).</p>	<p>“Intake Pipe Removal” procedure in Chapter 72-80</p>  <p>Figure 9 Intake Pipes</p>
<p>Step 7 Remove the starter ring gear support (Figure 7).</p>	<p>“Starter Ring Gear Support Removal” procedures in Chapter 72-70</p>  <p>Figure 7 Starter Ring Gear Support</p>	<p>Step 10 Remove the oil sump (Figure 10).</p>	<p>“Oil Sump Removal” procedure in Chapter 72-50</p>  <p>Figure 10 Oil Sump</p>

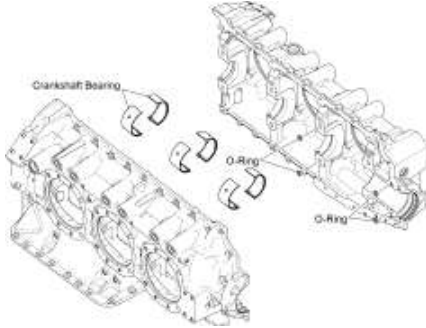
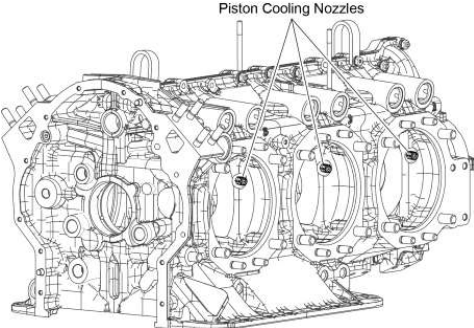
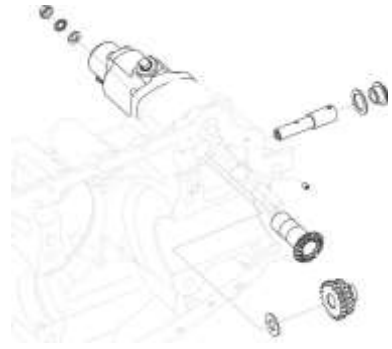
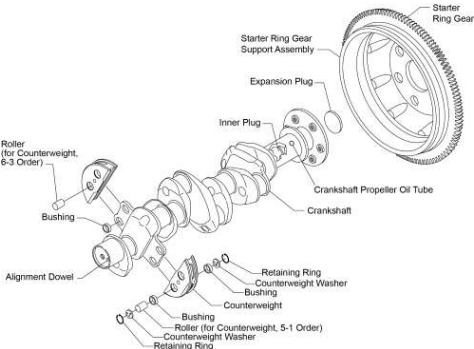
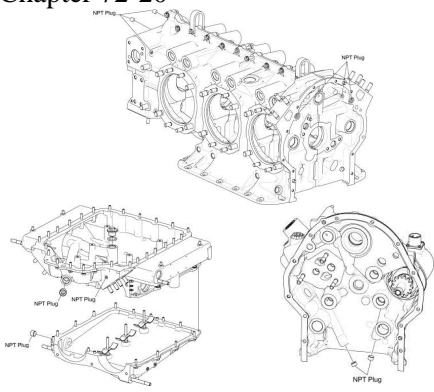
**Table 1 (Cont.)
Sequence of Engine Disassembly Procedures**

Step	Reference	Step	Reference
<p>Step 11 Remove the oil filter, oil cooler bypass valve, and hoses connecting to the oil cooler from the accessory housing (Figure 11).</p>	<p>Procedures in Chapters 12-10 and 72-50</p>  <p align="center">Figure 11 Oil Cooler Bypass Valve and Oil Filter</p>	<p>Step 14 Remove the high-speed idler gear, fuel pump drive shaft, crankshaft idler gears, and crankshaft trigger gear assembly (Figure 14).</p>	<p>“Crankcase Disassembly” procedure in Chapter 72-20</p>  <p align="center">Figure 14 Crankshaft Idler Gears</p>
<p>Step 12 Remove the accessories, electronic propeller governor, and accessory housing, (Figure 12).</p>	<p>Procedures in Chapter 72-20 and 72-25</p>  <p align="center">Figure 12 Accessory Housing and Electronic Propeller Governor</p>	<p>Step 15 Remove the oil drain tubes from the engine cylinder heads and crankcase (Figure 15).</p>	<p>“Oil Drain Tube Removal” procedure in Chapter 72-30</p>  <p align="center">Figure 15 Oil Drain Tubes</p>
<p>Step 13 Remove the oil pump (Figure 13).</p>	<p>“Oil Pump Removal” procedure in Chapter 72-25</p>  <p align="center">Figure 13 Oil Pump</p>	<p>Step 16 Remove the inter-cylinder baffles (Figure 16).</p>	<p>“Intercylinder Baffle Removal” procedure in Chapter 72-30</p>  <p align="center">Figure 16 Intercylinder Baffles</p>

**Table 1 (Cont.)
Sequence of Engine Disassembly Procedures**

Step	Reference	Step	Reference
<p>Step 17 Remove the rocker covers, valve rockers, rocker shafts, push rods, and shroud tubes (Figure 17).</p>	<p>“Cylinder Removal” procedure in Chapter 72-30</p>  <p align="center">Figure 17 Rockers, Shroud Tubes, and Push Rods</p>	<p>Step 20 Remove the connecting rods (Figure 20).</p>	<p>“Connecting Rod Removal” procedure in Chapter 72-20</p>  <p align="center">Figure 20 Connecting Rods</p>
<p>Step 18 Remove the engine cylinders (Figure 18).</p>	<p>“Cylinder Removal” procedure in Chapter 72-30</p>  <p align="center">Figure 18 Engine Cylinders</p>	<p>Step 21 Remove the oil pressure relief valve (Figure 21).</p>	<p>“Oil Pressure Relief Valve Removal” procedure in Chapter 72-50</p>  <p align="center">Figure 21 Oil Pressure Relief Valve</p>
<p>Step 19 Remove the pistons (Figure 19).</p>	<p>“Piston Removal” procedure in Chapter 72-30</p>  <p align="center">Figure 19 Piston</p>	<p>Step 22 Separate the crankcase halves (Figure 22).</p>	<p>“Crankcase Disassembly” procedure in Chapter 72-20</p>  <p align="center">Figure 22 Crankcase Halves</p>

**Table 1 (Cont.)
Sequence of Engine Disassembly Procedures**

Step	Reference	Step	Reference
<p>Step 23 Remove the tappets, main bearings, and O-rings (Figure 23).</p>	<p>“Tappet, Main Bearing and O-Ring Removal” in Chapter 72-20</p>  <p>Figure 23 Tappets, Main Bearings and O-Rings</p>	<p>Step 26 Remove the piston cooling nozzle (Figure 26).</p>	<p>“Piston Cooling Nozzle Removal” in Chapter 72-20</p>  <p>Figure 26 Piston Cooling Nozzles</p>
<p>Step 24 Remove the propeller governor drive (Figure 24)</p>	<p>“Propeller Governor Drive Removal/ Disassembly” in Chapter 72-20</p>  <p>Figure 24 Propeller Governor Drive</p>	<p>Step 27 Disassemble the crankshaft (Figure 27).</p>	<p>“Crankshaft Disassembly” in Chapter 72-20</p>  <p>Figure 27 Crankshaft Disassembly</p>
<p>Step 25 Remove the oil plugs (Figure 25).</p>	<p>“Oil Plug Removal” procedure in Chapter 72-20</p>  <p>Figure 25 Oil Plugs</p>		

This page intentionally left blank.

72-10 - ENGINE ASSEMBLY

1. Corrosion Prevention

⚠ CAUTION USE ONLY THE RECOMMENDED LUBRICANT OR EQUIVALENT DURING ENGINE ASSEMBLY.

Pre-Lubrication of Parts Before Assembly

Before assembly of each subassembly, clean all of the parts to remove the preservative oil, grease, and dirt per instructions in Chapter 05-30.

As preventive action, during engine assembly, apply the recommended lubricant for specified components identified in the latest revision of Service Instruction No. SI-1059.

If parts are not correctly lubricated, or if a lubricant other than what is recommended is applied to a part, engine parts could become scored before the engine oil has lubricated the parts during the first cycle of engine operation. This scoring can cause premature part failure, or, in some cases, engine failure.

2. Painting the Engine and Engine Components

Lycoming Engines recommends that the basic engine be painted as an assembly (without accessories, intake tubes, fluid lines, wiring harness), However, it is necessary to paint an individual component:

- Do not get paint on any mating surfaces or under the cylinder hold down nuts.
- There must be metal-to-metal contact to ensure proper torque.
- Mask mating surfaces and the area where the nut will contact the component surface.

Table 1 includes paint stripping and painting guidelines for components.

All paint is to be sprayed; however, if it is necessary to use a brush, use care to prevent an accumulation of pockets of paint. Refer to the paint manufacturer's instructions for drying and curing times.

Parts requiring use of paint for protection or appearance are to be painted in accordance with the recommendations using the following approved materials:

- Thinner - Toluene or equivalent (AMS3180 or equivalent Federal Spec. TT-T-548).
- Primer - Zinc chromate (AMS3110 or equivalent MIL-P-8585).
- Enamel - Phthalate resin type (AMS3125C or equivalent MIL- E-7729).

NOTICE: All machined bosses are to be masked before painting. Do not paint areas under hold-down nuts where torque is required.

Table 1
Paint Stripping and Painting Guidelines for Components

Aluminum and Steel Parts	<p><u>NOTICE:</u> It is not necessary to apply the primer coat of paint has not been removed from the part.</p> <p>(1) Clean and degrease the parts with mineral spirits or equivalent.</p> <p>(2) Apply one coat of zinc chromate primer, thinned with two parts toluene.</p> <p>(3) Air dry.</p> <p>(4) Apply one coat of enamel and bake at 250° to 300° F (121° to 149° C), for 1/2-hour.</p>
--------------------------	--

**Table 1 (Cont.)
Paint Stripping and Painting Guidelines for Components**

Magnesium Parts	<p>(1) Clean all traces of oil and grease from the part using a neutral, non-corrosive, degreasing medium followed by a rinse.</p> <p>(2) Immerse the part for 45 minutes in a hot dichromate solution (3/4 lb. (0.34 kg) of sodium dichromate to 1 gallon (3.8 liters) of water at 180° to 200°F (82° to 93°C) (as required).</p> <p>(3) Wash the part thoroughly in cold running water, dipped in hot water, and dried in an air blast.</p> <p>(4) Immediately paint the part with a primer coat and engine enamel, the same as aluminum parts.</p>
Shroud Tubes	<p>(1) Clean and degrease the shroud tube with mineral spirits or equivalent.</p> <p>(2) Dip the shroud tube in zinc chromate primer, thinned to spraying consistency.</p> <p>(3) Let the primer coat dry.</p> <p>(4) Paint the outside of the shroud tube with engine enamel.</p>
Cylinders	<p><u>NOTICE:</u> Paint the cylinder with a Phthalate resin type enamel (AMS3125C or equivalent MIL-E-7729) properly thinned with Toluene or equivalent (AMS3180 or equivalent Federal Spec. TT-T-548).</p> <p>(1) Remove all old paint from the cylinder. Paint strippers are usually organic solvents like MEK or acetone or toluene, etc. and typically will not cause any damage to metals. A vapor degreaser is best suited for this purpose.</p> <p><u>NOTICE:</u> Masking tape, corks, plugs, metal covers, etc. are acceptable for masking purposes.</p> <p>(2) Mask off the following parts of the cylinder:</p> <ul style="list-style-type: none"> • Rocker box section, including the rocker box flange • Both valve ports and flanges • Thermocouple hole • Spark plug holes • Push rod shroud tube holes • All other exposed threaded surfaces in which paint could accumulate <p>(3) Cover the flange area to prevent paint being applied where the cylinder hold-down nuts contact the cylinder flange.</p> <p><u>NOTICE:</u> In the next step, maximum thickness of the paint on the cylinder flange must be 0.0005 in. (0.0127 mm). Measure the thickness of the paint with a thickness gage or equivalent. If a thickness gage is not available, use a micrometer to measure the thickness of the flange before and after painting. If the paint is over 0.0005 in. (0.0127 mm) thick, remove the paint and repaint the cylinder flange.</p> <p>(4) Apply a very light sprayed coat of zinc chromate primer to a maximum thickness of (0.0005 in. (0.0127 mm) on the cylinder flange. If the correct amount of paint has been applied, the color of the paint will be green with a yellowish tint and the metal will show through. If the paint is too thick, the color will be zinc chromate yellow.</p>

**Table 1 (Cont.)
Paint Stripping and Painting Guidelines for Components**

Cylinders (Cont.)	<p>(5) Use a cloth dipped in paint thinner to remove paint from all surfaces where it could have accidentally accumulated.</p> <p>(6) Air-dry the cylinder or bake the cylinder in an oven until completely dry. Refer to the paint manufacturer's instructions for drying time and oven temperature.</p> <p>(7) Refer to Chapter 74-20 and paint the cylinder fin area appropriately for spark plug identification.</p>
-------------------	--

3. Limits and Clearances

Refer to the latest revision of the *Service Table of Limits - SSP-1776*, for the following.

- Backlash and end clearance of gears
- Clearance between mating machined parts
- Clearance between moving parts that touch
- Torque limits for various nuts, screws, and fasteners.

4. Inspections

NOTICE: Inspections in this section refer to reusable items that do not require replacement in accordance with the latest revision of Service Bulletin No. SB-240. Be sure to record part replacement or any corrective action in the engine logbook.

A. Bearing Shell Surface Inspection

- (1) Examine all bearing saddle surfaces for damage, scoring, galling, and wear. If any of these conditions are found, identify and correct the cause.
- (2) Make sure that the clearance of each bearing agrees with the specification in the latest revision of the *Service Table of Limits - SSP-1776*.
 - If a bearing is not in the specified limits in the latest revision of the *Service Table of Limit - SSP-1776*, discard it and replace it with a new one.
- (3) Examine all journal surfaces for galling, scores, misalignment, and out-of-round condition. Replace a scored, galled, misaligned, or out-of-round component.
- (4) Examine the shafts and pins for straightness.

B. Gear Inspection

- (1) Examine the involutes of the gear teeth for pitting and excessive wear.
 - If pit marks are found, discard the gear and replace it with a new one.
- (2) Examine the bearing surfaces of all gears for deep scratches.
- (3) Remove minor abrasions with a fine abrasive cloth.

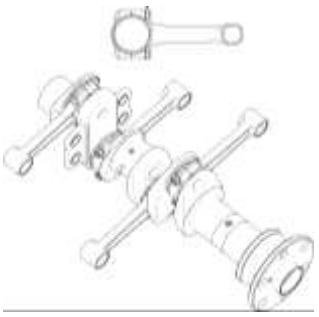
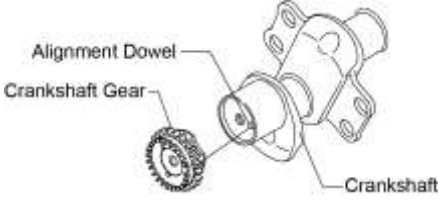
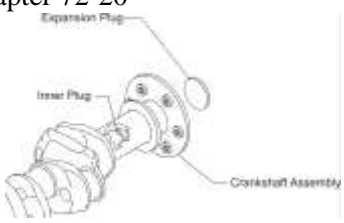

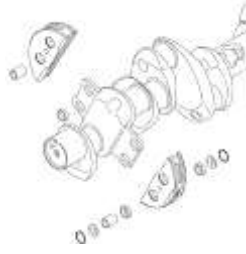
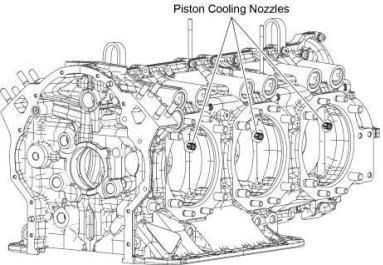
C. Screwed Fitting Inspection

- (1) Examine the condition of the threads on screwed fittings (threaded fastenings or plugs).
- (2) Remove small nicks and burrs with a small file, fine abrasive cloth, or stone.
 - If the part cannot be repaired by polishing it, discard it and replace it with a new one.
 - If the part has too much distortion, galling, or mutilation (caused by over-tightening or use of an incorrect tool) replace it.

Engine Assembly Procedure

- A. Complete the sequence of steps in Table 2.
- B. Copy and complete the *Engine Assembly Checklist* in this chapter as a record of maintenance for reference.

Table 2
Sequence of Engine Assembly Procedures

Step	Reference	Step	Reference
Step 1	Review the “General Assembly Practices” in this chapter	Step 5	“Connecting Rod Installation” procedure in Chapter 72-20
<p>Begin “Crankshaft Assembly” procedure. Complete the “Alignment Dowel Inspection” in Chapter 72-20.</p>		 <p style="text-align: center;">Figure 4 Connecting Rods</p>	
Step 2	<p>Ensure the crankshaft trigger gear assembly fits correctly in the counterbore end of the crankshaft (Figure 1).</p> <p>“Crankshaft Trigger Gear Assembly Fit Verification” procedure in Chapter 72-20</p>	 <p style="text-align: center;">Figure 1 Crankshaft Trigger Gear Assembly</p>	
Step 3	<p>Install a new expansion plug on the crankshaft (Figure 2).</p> <p>“Expansion Plug Installation” procedure in Chapter 72-20</p>	 <p style="text-align: center;">Figure 2 Expansion Plug</p>	
Step 4	<p>Start installation of the crankshaft solid-ring oil seal on the crankshaft (Figure 3). (or install the split oil seal later)</p> <p>“Solid-Ring Oil Seal Installation” procedure in Chapter 72-20</p>	 <p style="text-align: center;">Figure 3 Solid-Ring Oil Seal</p>	
Step 6	<p>Install the counterweights on the crankshaft (Figure 5).</p> <p>“Counterweight Installation” procedure in Chapter 72-20</p>	 <p style="text-align: center;">Figure 5 Counterweights</p>	
Step 7	<p>Install the piston cooling nozzles (if removed) (Figure 6).</p> <p>“Piston Cooling Nozzle Installation” (if removed)” procedure in Chapter 72-20</p>	 <p style="text-align: center;">Figure 6 Piston Cooling Nozzles</p>	

**Table 2 (Cont.)
Sequence of Engine Assembly Procedures**

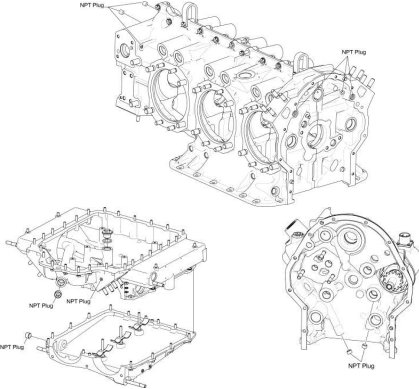
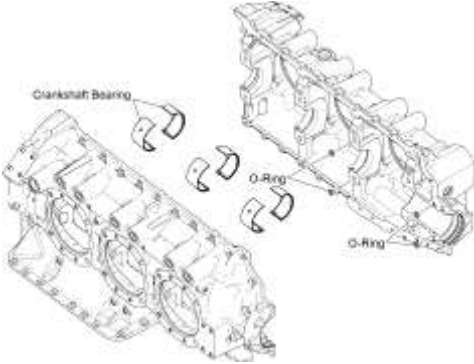
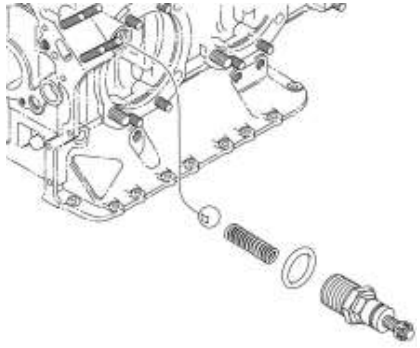
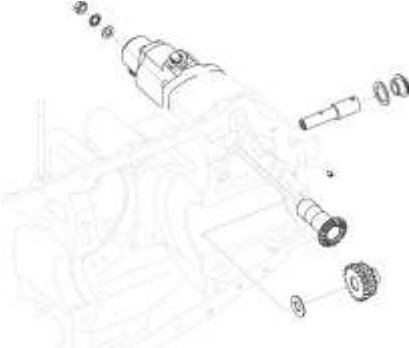
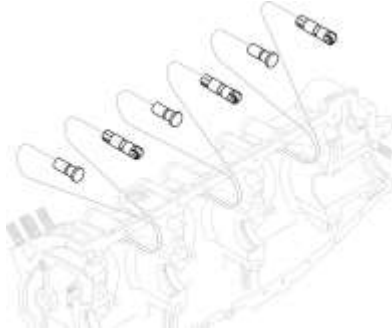
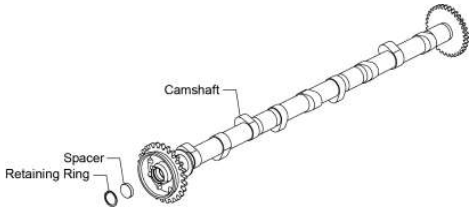
Step	Reference	Step	Reference
<p>Step 8 Install the oil plugs (if removed) (Figure 7).</p>	<p>“Oil Plug Installation” procedure in Chapter 72-20</p>  <p>Figure 7 Oil Plugs</p>	<p>Step 11 Install the main bearings and O-rings in the crankcase (Figure 10).</p>	<p>“Main Bearing and O-Ring Installation” procedure in Chapter 72-20</p>  <p>Figure 10 Main Bearings and O-Rings</p>
<p>Step 9 Install the oil pressure relief valve (Figure 8).</p>	<p>“Oil Pressure Relief Valve Installation” procedure in Chapter 72-50</p>  <p>Figure 8 Oil Pressure Relief Valve</p>	<p>Step 12 Install the propeller governor drive (Figure 11).</p>	<p>“Propeller Governor Drive Installation” in Chapter 72-20</p>  <p>Figure 11 Propeller Governor Drive</p>
<p>Step 10 Install the tappet assemblies (Figure 9).</p>	<p>“Tappet Assembly Installation” procedure in Chapter 72-20</p>  <p>Figure 9 Tappets</p>	<p>Step 13 Assemble and install the camshaft in the crankcase (Figure 12).</p>	<p>“Camshaft Assembly and Installation” procedure in Chapter 72-20</p>  <p>Figure 12 Camshaft</p>

Table 2 (Cont.)
Sequence of Engine Assembly Procedures

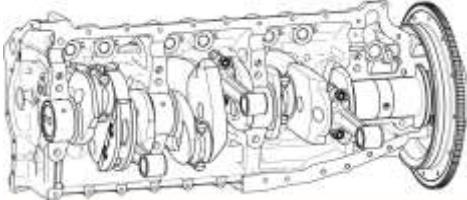
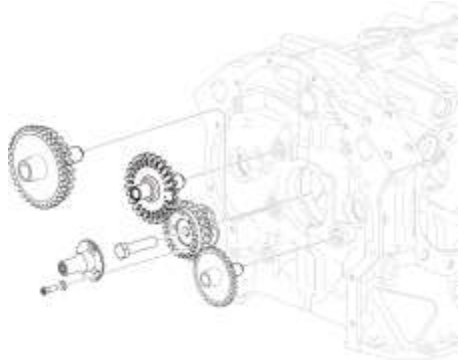
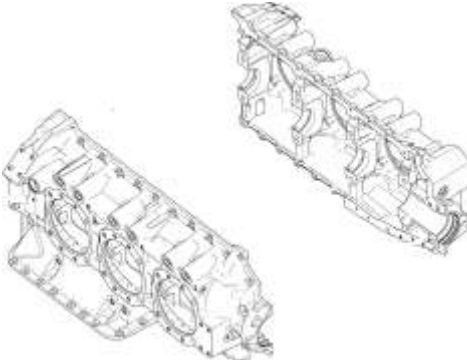
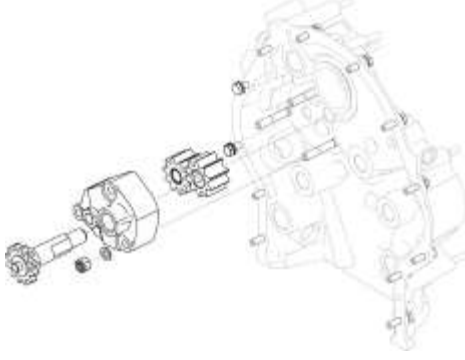

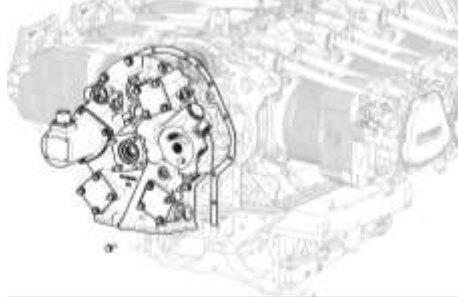
Step	Reference	Step	Reference
<p>Step 14 Install the crankshaft in the crankcase (Figure 13).</p>	<p>“Crankshaft Installation” procedure in Chapter 72-20</p>  <p align="center">Figure 13 Crankshaft</p>	<p>Step 17 Install the crankshaft trigger gear assembly, crankshaft idler gears, fuel pump drive shaft, and high-speed idler gear (Figure 16)</p>	<p>“Crankshaft Trigger Gear Assembly and Crankshaft Idler Gear Installation” procedure in Chapter 72-20</p>  <p align="center">Figure 16 Crankshaft Idler Gear Assemblies</p>
<p>Step 15 Assemble the crankcase halves (Figure 14).</p>	<p>“Crankcase Assembly” procedure in Chapter 72-20</p>  <p align="center">Figure 14 Crankcase Halves</p>	<p>Step 18 Install the oil pump on the accessory housing (Figure 17).</p>	<p>“Oil Pump Installation” procedure in Chapter 72-25</p>  <p align="center">Figure 17 Oil Pump</p>
<p>Step 16 Complete installation of the crankshaft oil seal in the crankcase (Figure 15)</p>	<p>“Crankshaft Oil Seal Installation” procedure in Chapter 72-20</p>  <p align="center">Figure 15 Split Oil Seal and Solid-Ring Oil Seal</p>	<p>Step 19 Install the accessory housing, oil filter, oil cooler bypass valve, and connect the oil hoses to the oil cooler (Figure 18).</p>	<p>Chapters 12-10, 72-25, and 72-50 in this manual and Airframe Manufacturer’s Maintenance Manual</p>  <p align="center">Figure 18 Accessory Housing</p>

Table 2 (Cont.)
Sequence of Engine Assembly Procedures

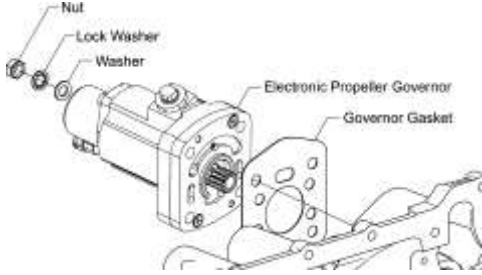
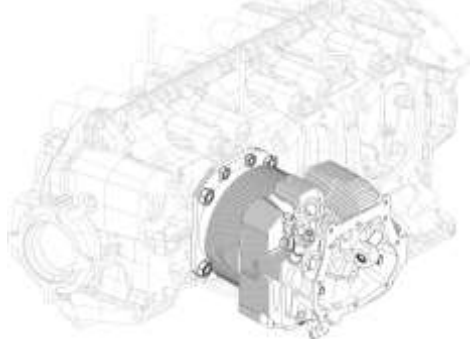
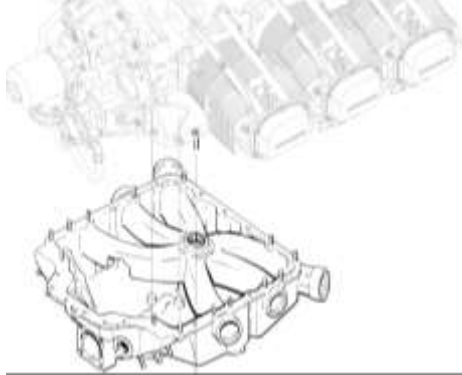
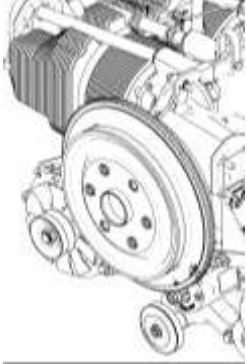
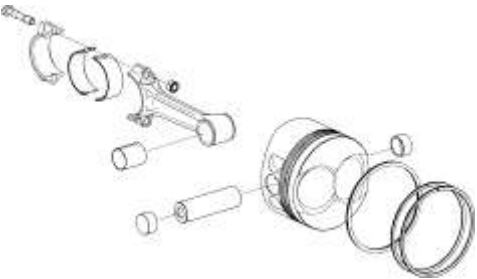
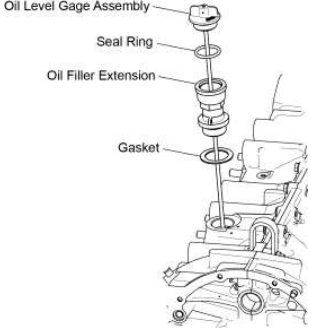
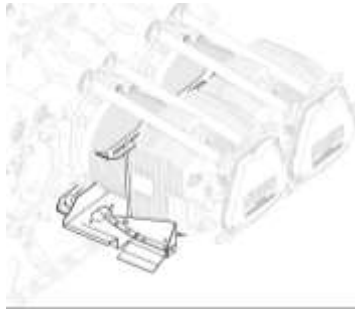
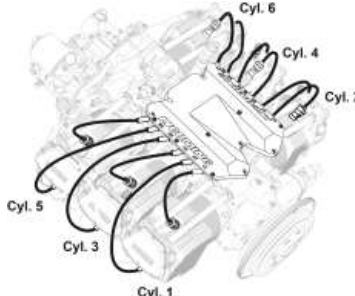
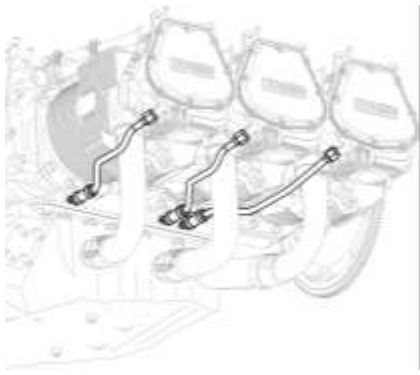
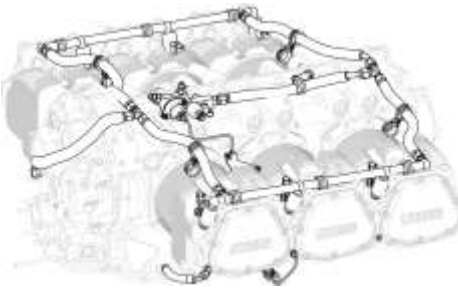
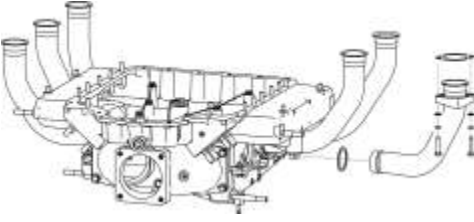
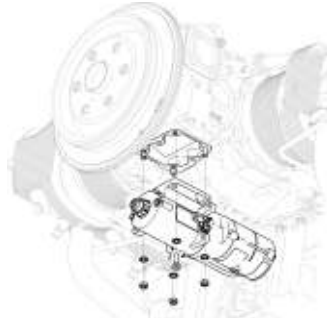
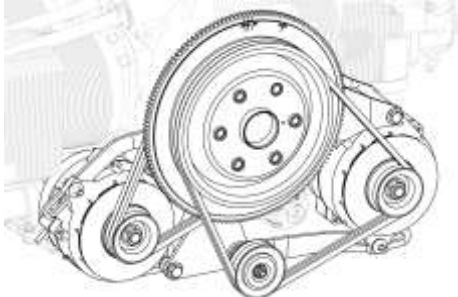
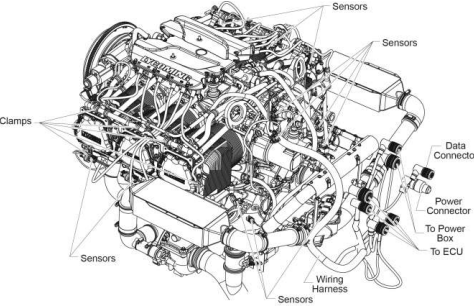
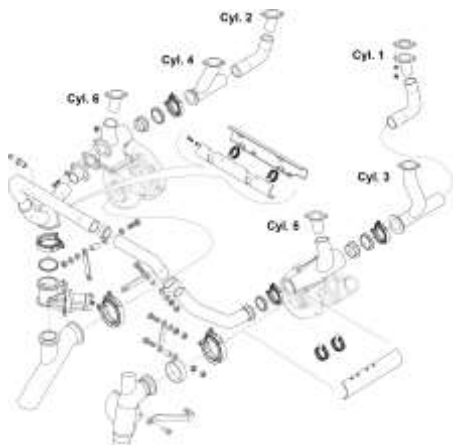
Step	Reference	Step	Reference
<p>Step 20 Install the electronic propeller governor (Figure 19)</p>	<p>“Electronic Propeller Governor Installation” section in Chapter 72-25</p>  <p align="center">Figure 19 Electronic Propeller Governor</p>	<p>Step 23 Install all six engine cylinders on the crankcase (Figure 22)</p>	<p>“Cylinder Installation” section in Chapter 72-30</p>  <p align="center">Figure 22 Engine Cylinders</p>
<p>Step 21 Install the oil sump on the crankcase (Figure 20)</p>	<p>“Oil Sump Installation” in Chapter 72-50</p>  <p align="center">Figure 20 Oil Sump</p>	<p>Step 24 Install the starter ring gear support on the engine (Figure 23)</p>	<p>“Starter Ring Gear Support Installation” procedures in Chapter 72-70</p>  <p align="center">Figure 23 Starter Ring Gear Support</p>
<p>Step 22 If removed install the piston in each engine cylinder (Figure 21)</p>	<p>“Piston Installation” procedure in Chapter 72-30</p>  <p align="center">Figure 21 Piston</p>	<p>Step 25 Install the oil level gage assembly (Figure 24).</p>	<p>“Oil Level Gage Assembly Installation” procedure in Chapter 72-50</p>  <p align="center">Figure 24 Oil Level Gage</p>

Table 2 (Cont.)
Sequence of Engine Assembly Procedures


Step	Reference	Step	Reference
<p>Step 26 Install inter-cylinder baffles (Figure 25).</p>	<p>“Intercylinder Baffle Installation” procedure in Chapter 72-30</p>  <p align="center">Figure 25 Intercylinder Baffle</p>	<p>Step 29 Install the spark plugs, coil box, and ignition leads (Figure 28).</p>	<p>Procedures in Chapters 74-20 and 74-30 in this manual</p>  <p align="center">Figure 28 Coil Box, Ignition Leads, and Spark Plugs</p>
<p>Step 27 Attach six new oil drain tubes, one on each engine cylinder head and the crankcase (Figure 26).</p>	<p>“Oil Drain Tube Installation” procedure in Chapter 72-30</p>  <p align="center">Figure 26 Oil Drain Tubes</p>	<p>Step 30 Install the, fuel pump, fuel pressure regulator, throttle body, fuel injector rail assemblies, and fuel hoses, (Figure 29).</p>	<p>Procedures in Chapters 73-10 and 73-20</p> <ul style="list-style-type: none"> • Fuel Pump Installation • Fuel Pressure Regulator • Throttle Body Installation • Fuel Injector Rail Assembly Installation • Fuel Hose Installation  <p align="center">Figure 29 Fuel System Components</p>
<p>Step 28 Install the intake pipes, each to the corresponding cylinder (Figure 27).</p>	<p>“Intake Pipe Installation” procedure in Chapter 72-80</p>  <p align="center">Figure 27 Intake Pipes</p>	<p>Step 31 Install the starter (Figure 30).</p>	<p>“Starter Installation” procedure in Chapter 72-70</p>  <p align="center">Figure 30 Starter</p>

**Table 2 (Cont.)
Sequence of Engine Assembly Procedures**

Step	Reference	Step	Reference
<p>Step 32 Install the alternators, and alternator belts (Figure 31).</p>	<p>“Alternator and Bracket Installation” and “Alternator Belt Installation” procedures in Chapter 72-70</p>  <p align="center">Figure 31 Alternator Bracket, Alternator, and Alternator Belt</p>	<p>Step 34 Install the sensors and engine-to-firewall wiring harness (Figure 33).</p>	<p>“Sensor Replacement Procedures” and “Engine-to-Firewall Wiring Harness Installation” procedure in Chapter 72-70</p>  <p align="center">Figure 33 Sensors and Wiring Harness</p>
<p>Step 33 Install the exhaust system and turbochargers (Figure 32).</p>	<p>Refer to Chapters 72-40 and 72-80</p>  <p align="center">Figure 32 Exhaust System</p>	<p>Step 35 Install the engine in the airframe</p>	<p>Install the engine in the airframe per instructions Chapter 72-00 in this manual, in the <i>TEO-540-A1A Engine Installation and Operation Manual</i>, and applicable Airframe Maintenance Manual.</p>
		<p>Step 36 Complete the field run-in, engine run-up, break-in, and flight test</p>	<p>Complete the field run-in, engine run-up, break-in, and flight test per the “Field Run-In” and “Engine Initiation” chapters of the <i>TEO-540-A1A Engine Installation and Operation Manual</i>.</p>

Engine Assembly Checklist

The Engine Assembly Checklist for TEO-540-A1A Engines is a guide and a record of completion for engine assembly.

Engine Assembly Checklist for TEO-540-A1A Engines		
Engine Serial Number: _____		Engine Time: _____
Date of Engine Assembly: _____		Engine Assembly done by: _____
Item	Comments	Done
Review the “General Assembly Practices” in this chapter and the latest revision of Service Bulletin No. SB-240 to identify all parts that must be replaced with new parts upon removal.		
Start with a clean crankshaft which passed the inspection, complete the “Crankshaft Inspection” in Chapter 72-20.		
Complete the “Alignment Dowel Inspection” and if necessary, replace the alignment dowel per the “Alignment Dowel Installation” procedure in the “Crankshaft Assembly” section in Chapter 72-20.		
 CAUTION FOR CORRECT ENGINE OPERATION, THE CRANKSHAFT TRIGGER GEAR ASSEMBLY MUST BE INSTALLED CORRECTLY WITH NO GAP IN THE MATING SURFACES BETWEEN THE COUNTERBORED END OF THE CRANKSHAFT AND THE CRANKSHAFT TRIGGER GEAR ASSEMBLY.		
Complete the “Crankshaft Trigger Gear Assembly Fit Verification” procedure in the “Crankshaft Assembly” section in Chapter 72-20.		
If using a fixed pitch propeller, install a new expansion plug in the crankshaft per the “Expansion Plug Installation” procedure in the “Crankshaft Assembly” section in Chapter 72-20 with a new crankshaft gear bolt.		
Either begin installation of a new solid-ring crankshaft oil seal on the crankshaft per the “Solid-Ring Crankshaft Oil Seal Installation” procedure in the “Crankshaft Assembly” section in Chapter 72-20 or later on install a split oil seal per the “Crankshaft Oil Seal Installation” procedure in Chapter 72-20. Consult the latest revision of SI1324.		
Complete the “Connecting Rod Inspection” in Chapter 72-20.		

Engine Assembly Checklist for TEO-540-A1A Engines (Cont.)		
Item	Comments	Done
<p>Per the “Connecting Rod Installation” procedure in the “Crankshaft Assembly” section in Chapter 72-20:</p> <ul style="list-style-type: none"> • Assemble and install the connecting rods (on the crankshaft) each with a new matched pair of bearing inserts, new connecting rod bolts, and new nuts. • Measure the side clearance between the connecting rod and crankshaft. The clearance is to be 0.004 to 0.016 in. (0.102 to 0.406 mm) 	Measurement:	
Install counterweights on the crankshaft per the “Counterweight Installation” procedure in the “Crankshaft Assembly” section in Chapter 72-20.		
Start with a clean crankcase which passed the “Exterior Crankcase Inspection” and “Interior Crankcase Inspection,” in Chapter 72-20.		
Complete the “Piston Cooling Nozzle Installation” procedure in Chapter 72-20.		
If the oil plugs were removed, complete the “Oil Plug Installation” procedure in Chapter 72-20.		
Complete the “Oil Pressure Relief Valve Installation” procedure in Chapter 72-50.		
<p>Complete the “Tappet Assembly Installation” procedure on Chapter 72-20.</p> <p>Identify the types of tappets installed in the engine logbook.</p>		
Complete the “Crankshaft Bearing and O-Ring Installation” procedure in Chapter 72-20.		
Complete the “Propeller Governor Drive Gear Installation” procedure in Chapter 72-20.		
<p>NOTICE Refer to the “Camshaft Replacement Guidelines” section in the latest revision of Service Instruction No. SI-1011 for guidelines on replacing the camshaft when new tappets are installed in the engine.</p>		
Complete the “Camshaft Disassembly and Inspection” in Chapter 72-20.		
Install the camshaft in the left crankcase half per the “Camshaft Installation” procedure in the “Camshaft Assembly and Installation” section of Chapter 72-20.		
<p>* Measurements must be within tolerances specified in the latest revision of the <i>Service Table of Limits - SSP-1776</i>.</p>		

Engine Assembly Checklist for TEO-540-A1A Engines (Cont.)		
Item	Comments	Done
Measure the camshaft end play in the left crankcase half per the “Camshaft Installation” procedure in the “Camshaft Assembly and Installation” section of Chapter 72-20.	*Measurement:	
Install the camshaft in the right crankcase half per the “Camshaft Installation” procedure in the “Camshaft Assembly and Installation” section of Chapter 72-20.		
Measure the camshaft end play in the right crankcase half per the “Camshaft Installation” procedure in the “Camshaft Assembly and Installation” section of Chapter 72-20.	*Measurement:	
Measure the crankshaft bearing journals. Refer to the “Crankshaft Bearing Surface Inspection” section in Chapter 72-20.	*Measurement:	
Complete the “Crankshaft Installation” procedure in Chapter 72-20.		
Measure the thrust face clearances between the crankshaft and crankcase per the “Crankshaft Installation” procedure in Chapter 72-20.	*Measurement:	
Measure the slinger clearance per the “Crankshaft Installation” procedure in Chapter 72-20.	*Measurement:	
Measure the crankshaft end play clearance per the “Crankshaft Installation” procedure in Chapter 72-20.	*Measurement:	
Assemble the crankcase halves per the “Crankcase Assembly” procedure and follow the torque sequence in Chapter 72-20.		
Complete the “Crankshaft End Play Clearance Check” in Chapter 72-20 (after the crankcase is assembled).		
Complete the “Propeller Oil Control Leak Test” in Chapter 72-20		
Complete the “Crankshaft Oil Seal Installation” procedure in Chapter 72-20.		
Complete the “Crankshaft Trigger Gear Assembly and Crankshaft Idler Gear Installation” procedure in Chapter 72-20.		
Complete the “Oil Pump Installation” procedure in Chapter 72-25.		
* Measurements must be within tolerances specified in the latest revision of the <i>Service Table of Limits - SSP-1776</i> .		

Engine Assembly Checklist for TEO-540-A1A Engines (Cont.)		
Item	Comments	Done
Complete the “Accessory Housing Installation” procedure in Chapter 72-25.		
Complete the “Electronic Propeller Governor Installation” procedure in Chapter 72-20.		
Complete the “Oil Cooler Bypass Valve Installation” procedure in Chapter 72-50.		
Complete the “Fuel Pump Installation” procedure in the “Fuel Pump Filter Replacement” section in Chapter 73-10.		
Complete the “Vacuum Pump Driven Gear Installation” procedure in the “Vacuum Pump Driven Gear Replacement (if installed)” section in Chapter 72-60.		
Complete the “Oil Sump Installation” procedure in Chapter 72-50. Be sure to install a new oil sump gasket.		
Complete the “Piston Installation” procedure in Chapter 72-30 for all six pistons. Make sure new piston rings and new piston pin plugs are installed on each piston.		
Complete the “Cylinder Installation” procedure in Chapter 72-30.		
(If necessary) complete the “Starter Ring Gear Replacement” procedure in Chapter 72-70.		
Install the starter ring gear support per the “Starter Ring Gear Support Installation” procedure in accordance with the “Starter Ring Gear Support Assembly Replacement” section in Chapter 72-70.		
Complete the “Oil Filler Extension and Oil Level Gage Assembly Installation” procedure in Chapter 72-50.		
Complete the “Intercylinder Baffle Installation” procedure in the “Cylinder Installation” section in Chapter 72-30.		
Install a new oil drain tube at each cylinder head and at the crankcase per the “Oil Drain Tube Installation” procedure in Chapter 72-30.		
Complete the “Intake Pipe Installation” procedure in accordance with the “Intake Pipe Replacement” section in Chapter 72-80.		
Examine, set the gap, rotate, and install the spark plugs per procedures in Chapter 74-20.		

Engine Assembly Checklist for TEO-540-A1A Engines (Cont.)		
Item	Comments	Done
Complete the “Coil Box Installation” procedure in Chapter 74-30.		
Complete the “Ignition Lead Installation” procedure in Chapter 74-20.		
Complete the “Throttle Body Installation” procedure in Chapter 73-20.		
Complete the “Fuel Regulator Adapter Manifold Assembly Installation” procedure in accordance with the “Fuel Regulator Adapter Manifold Assembly Replacement” section in Chapter 73-10.		
Install new fuel hoses per the “Fuel Hose Installation” procedure in the “Fuel Hose Replacement” section in Chapter 73-10.		
Complete the “Starter Installation” procedure in accordance with the “Starter Replacement” section in Chapter 72-70.		
Complete the “Alternator and Bracket Installation” procedure in Chapter 72-70.		
Complete the “Alternator Belt Installation” procedure in accordance with the “Alternator Belt Replacement” section in Chapter 72-70.		
Install the sensors per the “Sensor Replacement Procedures” in Chapter 72-70.		
Complete the “Engine-to-Firewall Wiring Harness Installation” procedure in Chapter 72-70.		
Complete the “Exhaust System Installation” in Chapter 78-00.		
Complete the “Turbocharger Installation” in Chapter 72-40.		
Install the engine in the airframe per instructions in the <i>TEO-540-A1A Engine Installation and Operation Manual</i> and applicable Airframe Maintenance Manual.		
Complete the “Add Oil to the Engine” procedure in Chapter 12-10.		
Complete an “Operational Ground Check” per Chapter 72-00.		
Complete the field run-in, engine run-up, break-in, and flight test per the “Field Run-In” and “Engine Initiation” chapters of the <i>TEO-540-A1A Engine Installation and Operation Manual</i> .		

72-15- PROPELLER FLANGE BUSHING REPLACEMENT

1. Propeller Flange Bushing Removal

NOTICE: Designated bushings are installed in specified locations on the propeller in a particular indexed configuration.

- A. During removal of the bushings from the propeller flange (also known as the crankshaft flange), attach a removable non-adhesive label/tag on the bushing that identifies the correct bushing part number and location for reference on reassembly.
- B. Use the Propeller Flange Bushing Remove/Install Tool ST-115 to remove each bushing from the propeller flange.

2. Propeller Flange Bushing Installation

⚠ CAUTION IF THE PROPELLER FLANGE BUSHING OF THE CORRECT PART NUMBER IS NOT INSTALLED IN THE SPECIFIED LOCATION, THE PROPELLER WILL NOT BE INDEXED CORRECTLY. EXCESSIVE PROPELLER BLADE STRESSES CAN OCCUR.

- A. Refer to Figure 1 or the latest revision of the *TEO-540-A1A Illustrated Parts Catalog* to identify the correct bushing part numbers for your engine and the location of each bushing.
- B. Use the Propeller Flange Bushing Remove/Install Tool ST-115 to install the bushings of the correct part number on the propeller flange in the location designated for your engine model specified in Figure 1.

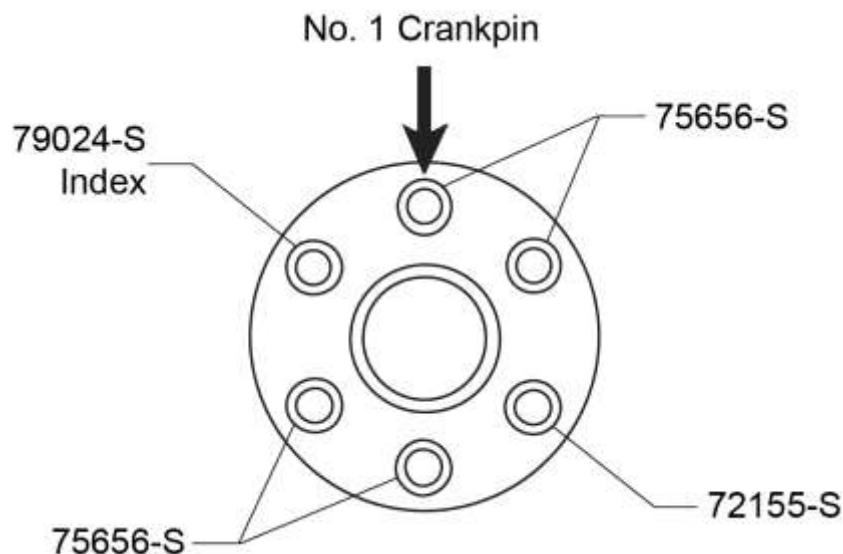


Figure 1
Propeller Flange Bushing Locations
 (Viewed from the front of the engine looking aft)


This page intentionally left blank.

72-20 - CRANKCASE MAINTENANCE

1. Exterior Crankcase Inspection

A. The exterior inspection of both crankcase halves is done to:

- Identify any oil leaks, cracks, and mechanical damage on the crankcase
- Make sure that hardware fasteners are torqued correctly


 WARNING IF A DAMAGED OR CRACKED CRANKCASE IS NOT REPLACED, OIL CAN LEAK OUT OF THE CRANKCASE AND CAUSE ENGINE DAMAGE. DO NOT TRY TO WELD OR REPAIR A CRACKED CRANKCASE. REPLACE BOTH CRANKCASE HALVES AS A MATCHED SET EVEN IF ONLY ONE CRANKCASE HALF IS DAMAGED OR CRACKED.

B. Examine the external surface of both crankcase halves. If any of the following are found, replace both crankcase halves:

- Any raised metal on surfaces
- Any scratch, ding, dent, or, pit that exceeds 0.050 in. (1.27 mm) depth
- Any crack

NOTICE: Even if only one crankcase half is worn, damaged, or cracked, replace both crankcase halves as a matched set.

C. Examine the crankcase breather fitting for cracks, dents, and damage. If cracks, dents or damage are found, replace the breather fitting.

 CAUTION LOOSE CYLINDER BASE NUTS ON THE THRU-STUDS ARE AN INDICATION THAT THERE IS NOT A UNIFORM LOAD ON THE MAIN BEARINGS IN THE CRANKCASE. ENGINE DAMAGE CAN OCCUR. DISASSEMBLE THE ENGINE PER INSTRUCTIONS IN THIS CHAPTER TO IDENTIFY DAMAGE.

D. Examine hold-down nuts on the cylinder head for looseness or damage. Replace loose or damaged nuts or studs.

NOTICE: In the next step, do not use a torque tool (to prevent over-torque) during the check for loose crankcase thru-bolts.

E. Examine the crankcase hardware fasteners for looseness or damage.

F. Replace any crankcase hardware fastener that is distorted, has corrosion or stripped threads and torque per instructions in this chapter.

G. Examine the crankshaft oil seal for leakage or damage. Replace a leaking or damaged oil seal.

NOTICE: To replace a leaking or damaged crankshaft oil seal with the engine assembled refer to instructions in the latest revision of Service Instruction No. SI-1324.

2. Connecting Rod Removal

CAUTION DO NOT RE-USE THE CONNECTING ROD BEARINGS, BOLTS, AND NUTS.

NOTICE: If the two bolts in the connecting rod cap cannot easily be removed, use a soft (plastic head) mallet and gently tap on the end of the two bolts to remove the bolts.

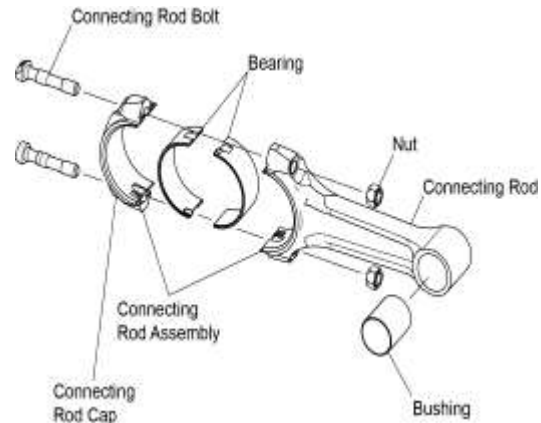


Figure 1
Connecting Rod Parts

- A. Remove and discard the two nuts (Figure 1) also discard the two bolts that attach the connecting rod cap to the connecting rod.
- B. Remove the connecting rod cap and connecting rod; keep them together, apply a label to identify the throw position of the connecting rod for reference on assembly.
- C. Remove and discard the two connecting rod bearings. Note excessive wear for repair.

3. Crankcase Disassembly

- A. Put the crankcase upright on a suitable work surface.
- B. Remove the high-speed idler gear (Figure 2) from the crankcase.
- C. Cut, remove, and discard the safety wire (Figure 3) from the three screws in the fuel pump drive shaft.
- D. Remove the three screws and washers from the fuel pump drive shaft.
- E. Remove the fuel pump drive shaft and the crankshaft gear bolt. Discard the crankshaft gear bolt.
- F. Remove the crankshaft trigger gear assembly, left crankshaft idler gear, and right crankshaft idler gear from the crankcase.

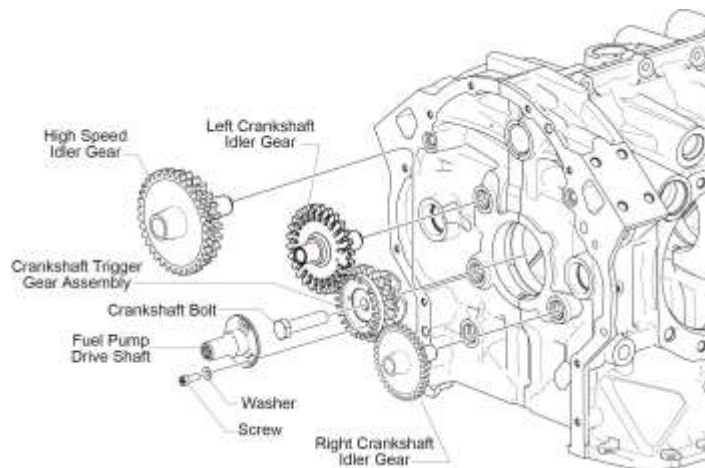


Figure 2
Crankshaft Trigger Gear Assembly and Crankshaft Idler Gears



Figure 3
Safety Wire on the Fuel Pump Drive Shaft Screws

⚠ CAUTION TO PREVENT DAMAGE TO THE CRANKCASE, REMOVE ALL THRU-STUDS, NUTS, AND BOLTS FROM THE CRANKCASE HALVES BEFORE YOU SEPARATE THE CRANKCASE HALVES.

- G. Use a slide hammer, a crankcase thru-stud puller ST-271 or crankcase thru-stud driver ST-317 or a plastic hammer to remove the eight thru-studs from the crankcase (Figure 4).

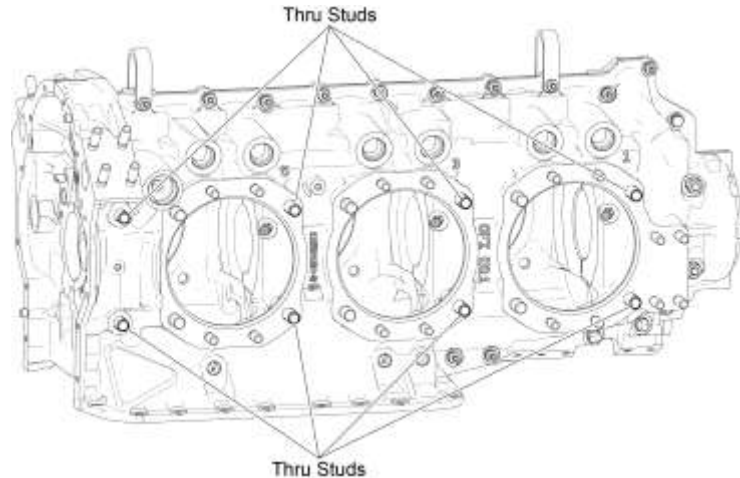


Figure 4
Crankcase Assembly

- H. Cut, remove, and discard the safety wire on the six nuts on the bottom of the crankcase that were inside the oil sump.
- I. Remove the remaining bolts and nuts that attach the crankcase halves.
- J. Insert one used pushrod into each of the eight holes where the thru-studs were removed to support the camshaft and crankshaft when the crankcase halves are separated.
- K. Separate the crankcase with a Crankcase Separating Tool ST-389 or with a slide-hammer attached to one of the base studs as shown in Figures 5, 6, and 7.



Figure 5
Attach the Slide-Hammer
to a Base Stud



Figure 6
Strike the Slide Part of the Tool
Against the Back of the Tool



Figure 7
Separate the
Crankcase Halves

- L. Remove the camshaft when the crankcase halves are separated enough to allow for removal (Figure 8).
- M. Continue separating the crankcase halves until the crankshaft can be removed from the crankcase (Figure 9).



Figure 8
Remove the Camshaft



Figure 9
Remove the Crankshaft

- N. Put the crankshaft in a suitable V-block-type fixture as shown in Figure 10.

NOTICE: Undersize crankshafts are identified by a code symbol stamped on the front of the flange as a suffix to the part number. In addition to the code symbols, the letters "RN" are stamped as a suffix to the serial number, indicating that the crankshaft has been renitrided.

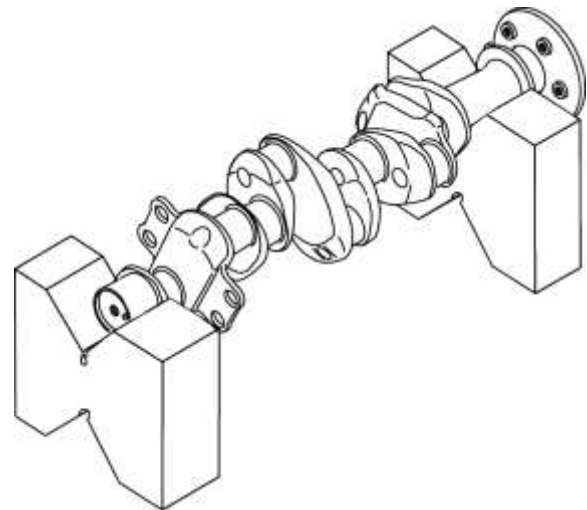


Figure 10
Crankshaft in V-Block-Type Fixture

- O. Tappet, Main Bearing, and O-Ring Removal

(1) Remove the hydraulic tappet plungers using the Tappet Assembly Tool P/N 64941.

⚠ CAUTION: IF A TAPPET ASSEMBLY TOOL IS NOT AVAILABLE, REMOVE THE PUSH ROD SOCKETS BY HAND OR BY MAKING A LOOP FROM A SHORT LENGTH OF SAFETY WIRE. DO NOT USE A MAGNET TO REMOVE THE SOCKET OR THE PLUNGER ASSEMBLY FROM THE ENGINE, AS THIS COULD CAUSE THE BALL TO REMAIN OFF ITS SEAT AND MAKE THE UNIT INOPERATIVE.

(2) Remove the push rod socket (Figure 11) by placing heavy grease on the ball end of the Tappet Assembly Tool. Push the greased ball end of the Tappet Assembly Tool into the socket and withdraw it. The socket will adhere to the grease.

- (3) Push the hollow end of the Tappet Assembly Tool over the hydraulic tappet plunger and withdraw the plunger.
- (4) Bend a right angle in one end of a piece of wire and insert this end into the space between the plunger assembly and the tappet body. Turn the wire 90° to engage a coil of the spring and draw out the hydraulic tappet plunger assembly. Refer to Figure 12.



Figure 11
Removing Push Rod Socket

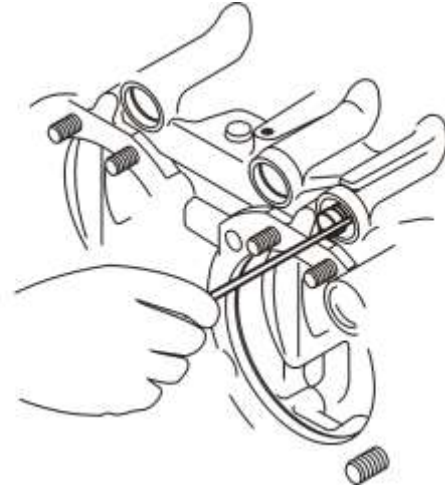


Figure 12
Removing Hydraulic Tappet Plunger Assembly

- (5) Remove and discard the crankshaft bearings, crankshaft front bearings, and O-rings (Figure 13).

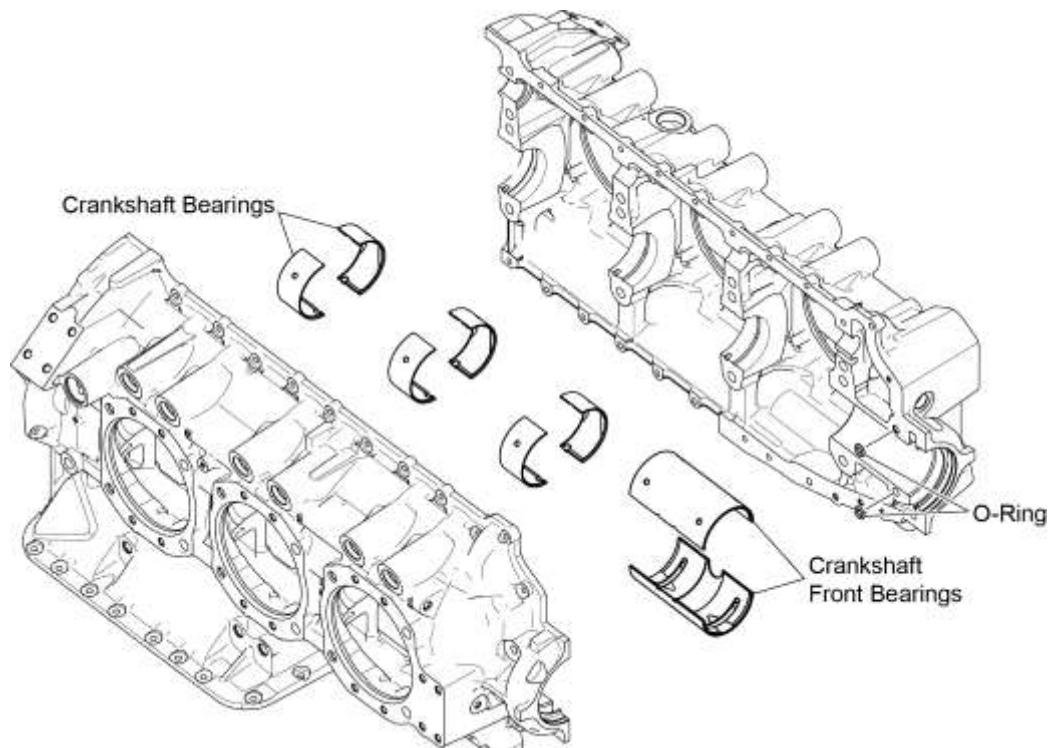


Figure 13
Main Bearings and O-Rings

P. Propeller Governor Drive Removal/Disassembly

- (1) If not already done, remove the four nuts, lock washers and washers (Figure 14) from the propeller governor or the propeller governor drive cover. Discard the lock washers.

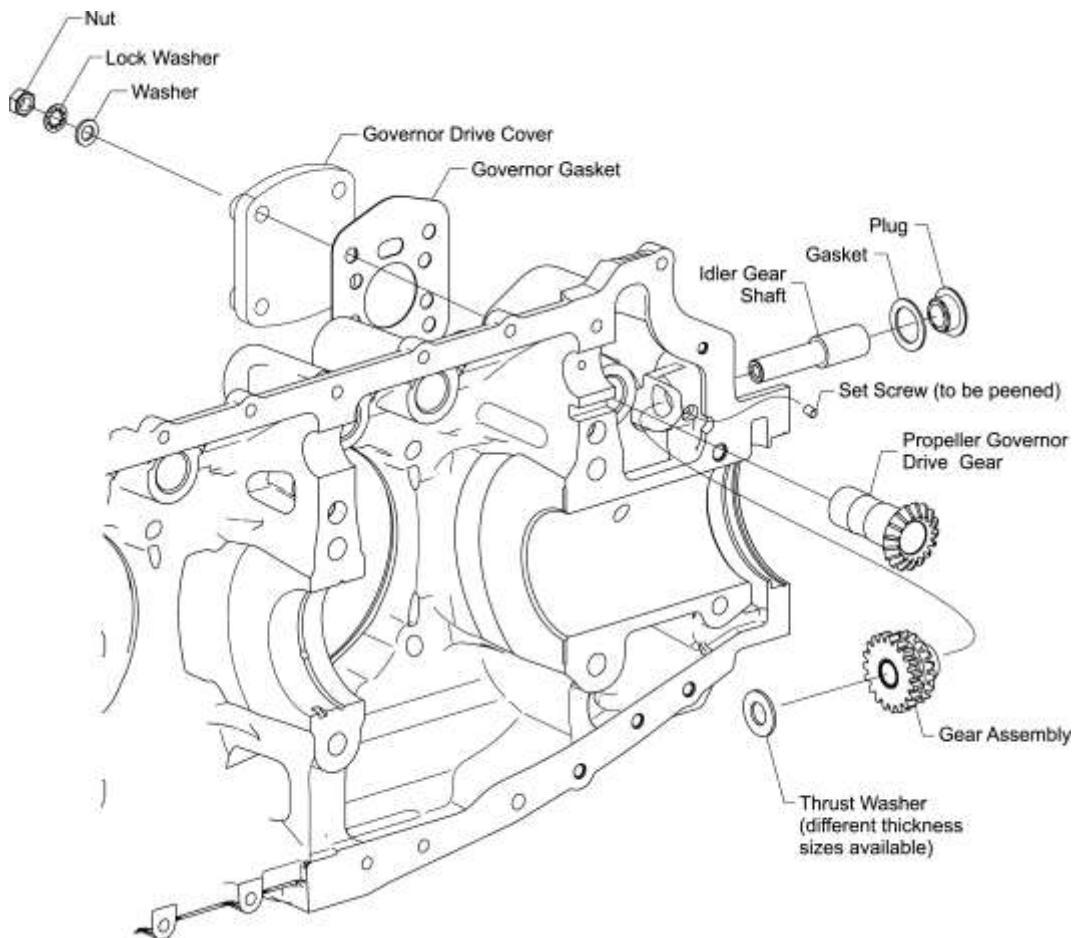


Figure 14
Propeller Governor Drive

- (2) Remove the propeller governor or the propeller governor drive cover and governor gasket. Discard the governor gasket.
- (3) Cut and remove the safety wire/cable from the idler gear shaft plug (Figure 14).
- (4) Remove the idler gear shaft plug and gasket from the crankcase. Discard the gasket.
- (5) Remove and discard the set screw from the propeller governor idler gear shaft. If the set screw was peened or staked in the hole, remove any debris.
- (6) Support the propeller governor idler gear shaft and, simultaneously remove the idler gear shaft, gear assembly, and thrust washer. Discard the thrust washer.

NOTICE: Do not remove the dowels or bushings from the gear assembly. If any part of the gear assembly is damaged, replace the entire gear assembly.

- (7) Pull the propeller governor drive gear away from the crankcase.

- Q. Remove the threaded oil (NPT) plugs from the accessory housing, oil sump/induction system, and crankcase to facilitate cleaning (Figures 15, 16, and 17).

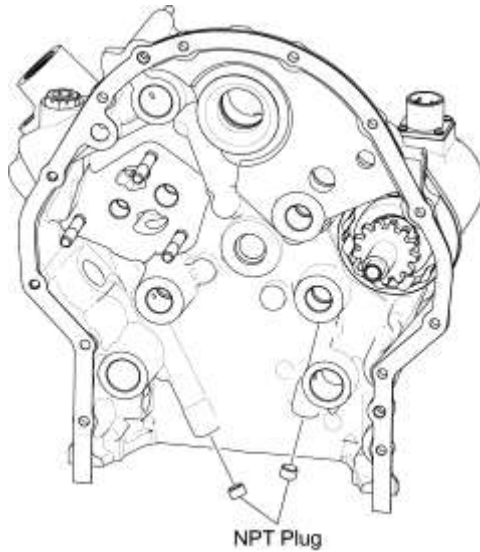


Figure 15
Oil Plugs in the Accessory Housing

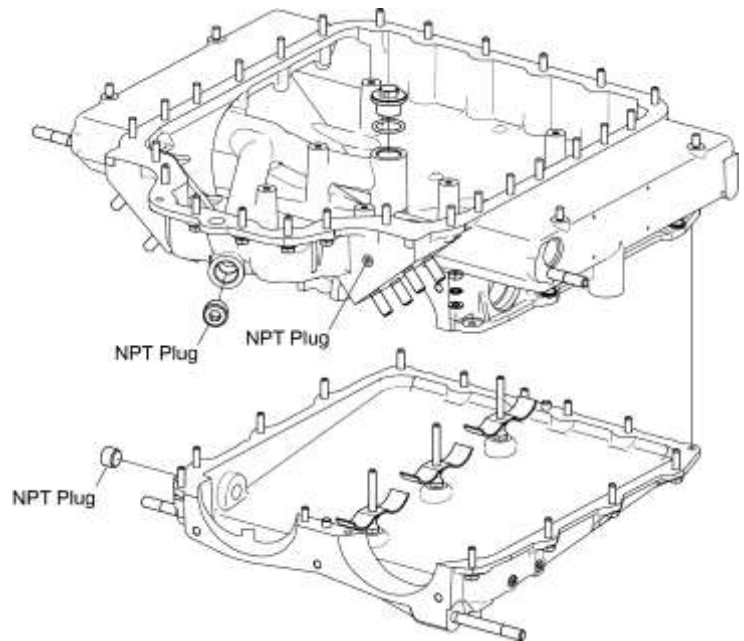


Figure 16
Oil Plugs in the Oil Sump/Induction System

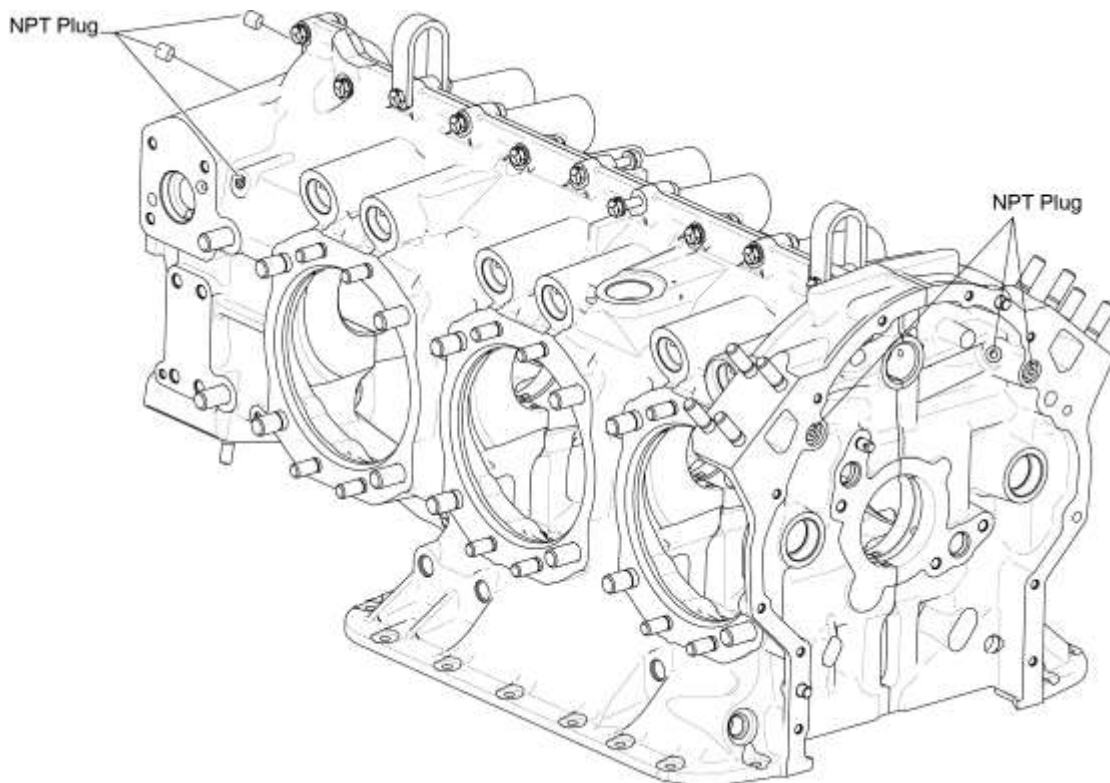


Figure 17
Oil Plugs in the Crankcase

R. Remove the six piston cooling oil nozzles from the crankcase (Figure 18).

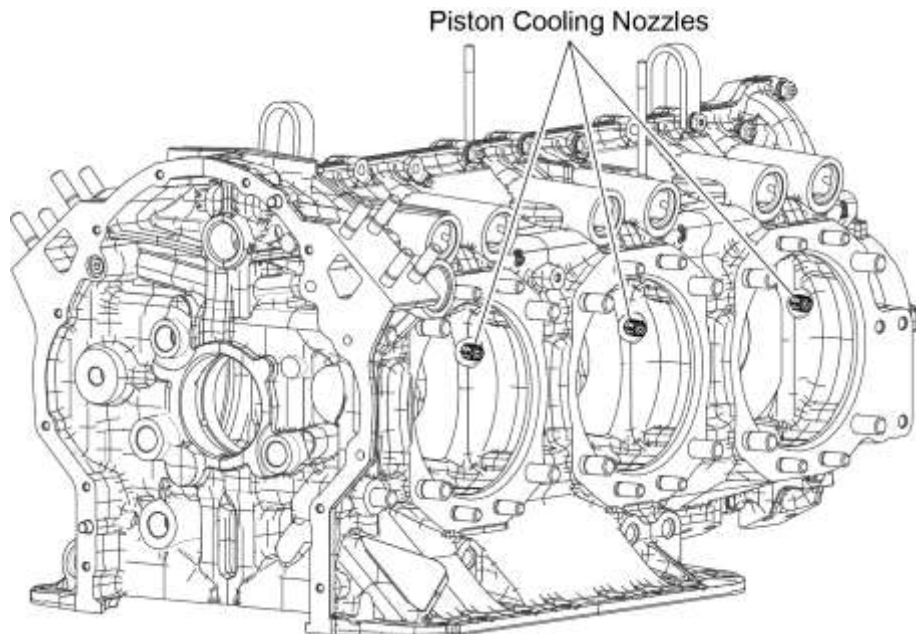


Figure 18
Piston Cooling Nozzles

4. Crankshaft Disassembly

▲ WARNING USE CARE WHEN HANDLING THE CRANKSHAFT AND ITS PARTS – DO NOT ETCH OR MAKE MARKS ON THE CRANKSHAFT. AN ETCH OR A MARK CAN CAUSE WEAKNESS AND FATIGUE IN THE CRANKSHAFT, WHICH COULD CAUSE CRANKSHAFT FAILURE.

NOTICE: Any time the crankshaft gear bolt (Figure 2) is removed from the crankshaft trigger gear assembly, the bolt is to be discarded and replaced with a new bolt for the applicable crankshaft trigger gear assembly. The discarded bolt is not to be re-installed on any engine.

Do not remove the alignment dowel (Figure 19) from the end of the crankshaft unless it is damaged. Replace a damaged alignment dowel per the “Alignment Dowel Replacement” procedure in this chapter.

Do not remove the propeller flange bushings unless they are loose or damaged (Chapter 72-15).

NOTICE: Skip the next step if a constant speed propeller is used because an expansion plug is not installed in the crankshaft.

▲ CAUTION: DO NOT DRILL THE EXPANSION PLUG OR USE A MAGNET TO REMOVE THE PLUG OR ANY LITTLE PIECES OF PLUG REMNANTS. ALWAYS POSITION THE PUNCH OR SHARP TOOL IN THE CENTER OF THE EXPANSION PLUG TO PREVENT DAMAGE TO THE INNER SURFACE OF THE CRANKSHAFT WHICH WILL REQUIRE REPLACEMENT OF THE CRANKSHFT.

A. Expansion Plug Removal (if installed):

- (1) Use a suitable 1/2 in. to 3/4 in. diameter punch to press the center of the expansion plug (Figure 19) to a concave shape in the crankshaft.
- (2) Use a sharp tool to make a 1/8 in. to 3/16 in. hole in the center of the plug.
- (3) Use a hook or bent rod to pull out the plug.
- (4) Remove any little pieces of plug remnants. Discard the expansion plug.

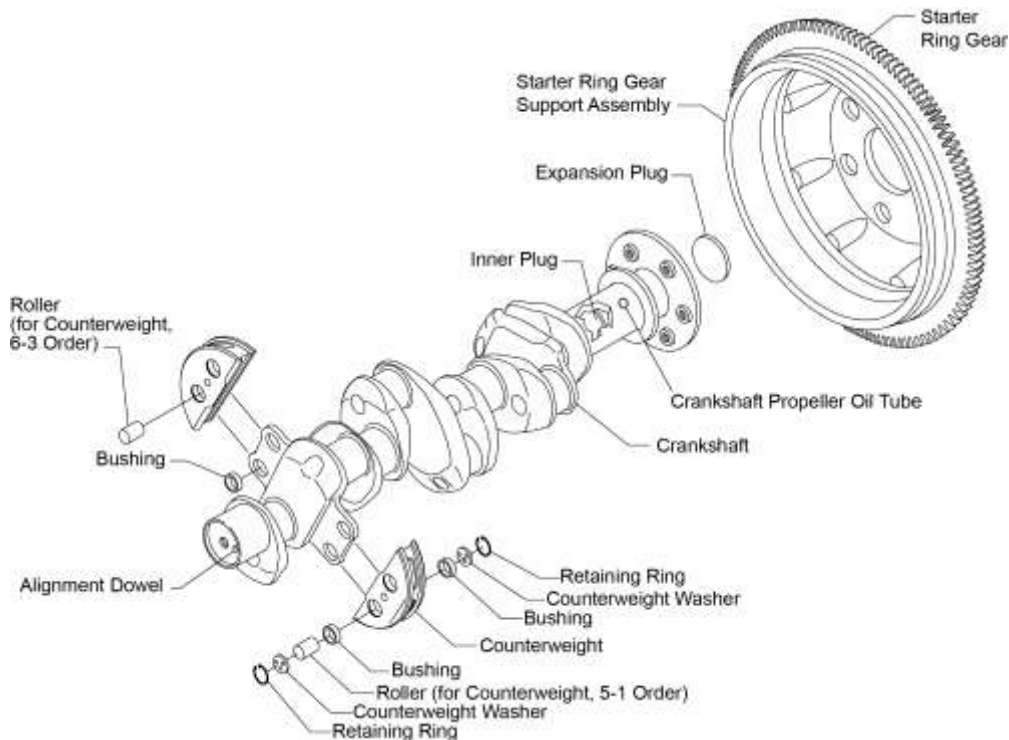


Figure 19
Crankshaft and Counterweight Assembly

CAUTION USE CARE NOT TO DAMAGE THE CRANKSHAFT WHEN REMOVING THE CRANKSHAFT OIL SEAL.

B. Remove the crankshaft oil seal from the crankshaft. If necessary cut the spring with wire cutters and cut the seal with side-cutter pliers to remove a solid-ring crankshaft oil seal.

C. Counterweight Removal

CAUTION: WHEN HANDLING COUNTERWEIGHTS AND ROLLERS, DO NOT MAKE SCORES, SCRATCHES, OR ETCH MARKINGS OF ANY KIND ON THE CRANKSHAFT AND ROLLERS. A MARK IN ANY OF THESE AREAS CAN CAUSE THE PART TO WEAKEN AND POSSIBLY FAIL.

NOTICE: Counterweights (Figure 20) of a specific order are installed in specified locations identified in the latest revision of Service Instruction No. SI-1012.

During counterweight removal, identify the counterweight and its location on a non-adhesive label and temporarily apply this label to the counterweight for reference on reassembly.

- (1) Remove each counterweight from the crankshaft. Apply the non-adhesive label to identify the location and position of the crankshaft for reference on reassembly

NOTICE: Since every counterweight has a matched pair of rollers that must stay with each counterweight, make another non-adhesive label to identify the roller pair that goes with each counterweight. Apply the label to the roller pair during removal to prevent mixing the roller pairs on different counterweights during reassembly.

- (2) Remove the two retaining rings (or circlips), two washers, and matched roller pair (Figure 20) from each counterweight. Discard the retaining rings and washers regardless of condition.

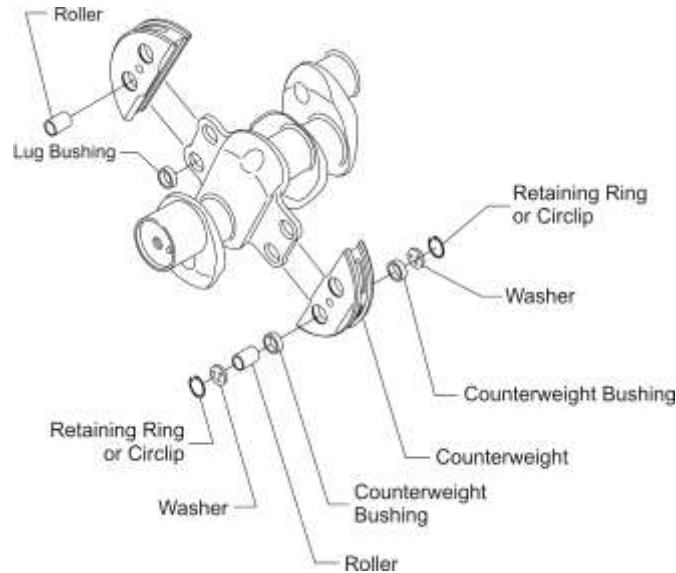


Figure 20

Counterweight, Rollers, Counterweight Bushings, and Lug Bushings (Crankshaft Dynamic Counterweight Bushings)

CAUTION COUNTERWEIGHT BUSHINGS MUST ALWAYS BE REPLACED AS A SET WITH NEW COUNTERWEIGHT BUSHINGS WHENEVER THESE BUSHINGS ARE REMOVED. DAMAGE OR WEAR ON THE CRANKSHAFT OR COUNTERWEIGHT BUSHINGS COULD CAUSE FAILURE OF THE COUNTERWEIGHT AND/OR THE CRANKSHAFT. REPLACE THE COUNTERWEIGHT ROLLERS WITH NEW COUNTERWEIGHT ROLLERS WHEN THE COUNTERWEIGHT BUSHINGS ARE REPLACED.

NOTICE: All counterweight bushings on all of the counterweights must be replaced at the same time.

If a lug bushing (Figure 20) is damaged, replace it per instructions in the latest revision of Service Instruction No. SI-1142.

- (3) Remove the counterweight bushings in the steps below.

Tools to be used include:

- Arbor Press Spindle
- Counterweight Bushing Driver ST-92
- Counterweight Fixture Assembly ST-93
- Depth Control Spacer ST-93-3
- Depth Control Spacer ST-93-5

- (a) Put the counterweight flat on the table, square and level against the Arbor Press Spindle.
- (b) Install the applicable Depth Control Spacer ST-93-3 or ST-93-5 (Figure 21) in the counterweight bushing bore.
- (c) Use the Arbor Press Spindle and Counterweight Bushing Driver ST-92 to press each bushing out from one side of the counterweight. Refer to Figure 21. Discard the bushings.
- (d) Turn the counterweight over.
- (e) Use the Arbor Press Spindle and Counterweight Bushing Driver ST-92 to press out and remove each bushing on the other side of the counterweight. Discard the bushings.

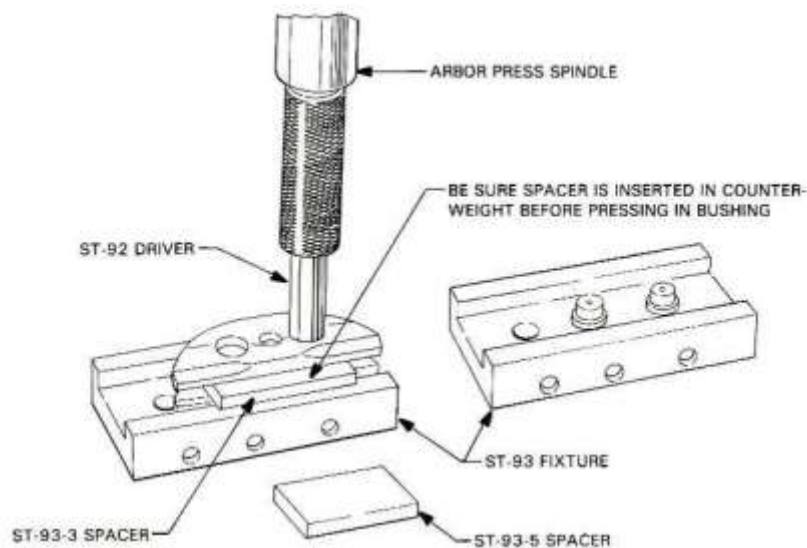


Figure 21
Counterweight Bushing Removal/Installation
Using the Counterweight Fixture Assembly ST-93
and the Counterweight Bushing Driver ST-92

5. Interior Crankcase Inspection

The interior crankcase inspection is done to identify cracks and mechanical damage within the crankcase:

⚠ WARNING REPLACE A DAMAGED OR CRACKED CRANKCASE. DO NOT TRY TO WELD OR REPAIR A CRACKED CRANKCASE. IF A DAMAGED OR CRACKED CRANKCASE IS NOT REPLACED, OIL CAN LEAK OUT OF THE CRANKCASE AND CAUSE ENGINE DAMAGE.

- A. Visually examine the interior surface of the crankcase for cracks and damage.
- B. Complete a fluorescent particle inspection on both crankcase halves. Copy and complete the “Results of Fluorescent Penetrant Inspection of Crankcase” checklist.
- C. If one or both crankcase halves has a crack or is damaged, replace both crankcase halves as a matched set.

Results of Fluorescent Penetrant Inspection of Crankcase		
Crankcase P/N		Inspector
Crankcase S/N		Date of Inspection
Black Light Inspection of Crankcase		
Inspection Item	Guidelines and Corrective Action	Findings and Action Taken
Look for fatigue crack(s) or start of crack(s) in the crankcase Look for cracks caused by heat or brittleness	Start of cracks or crack(s) found - replace both crankcase halves	Acceptable Replace
Look for inappropriate repair, such as grinding to remove corrosion in the crankcase.	Evidence of grinding - replace both crankcase halves	Acceptable Replace
Comments/Notes:		

D. Crankcase Dimensional Inspection

The crankcase dimensional inspection is done to make sure that the crankshaft bearings and camshaft bearing saddles (Figure 13) formed by the crankcase halves are within allowable limits.

Complete the crankcase dimensional inspection as follows:

- (1) Install new crankshaft bearings at all main bearing locations in the crankcase halves (Figure 13).
- (2) Assemble the crankcase halves and install thru-studs (Figure 4).
- (3) Use washers and nuts on the thru-studs to install the Torque Hold-Down Plates (ST-222, Figure 83) at the cylinder pads over the thru-studs. Tighten the nuts only finger tight at this time.
 - (a) Make sure that the Torque Hold-Down Plates remain parallel with the cylinder decks of the crankcase.
 - (b) Temporarily torque the nuts to 300 in.-lb. (34 Nm).
- (4) Attempt to insert a 0.004 in. tapered feeler gage between the crankcase mating faces. If the gage will not enter between the crankcase parting faces, the crankcase is considered satisfactory.
- (5) Make a copy and complete the Crankcase Dimensional Inspection Checklist for TEO-540-A1A Engines.
- (6) Remove the nuts, washers, and Torque Hold-Down Plates (ST-222), and separate the crankcase halves.



Crankcase Dimensional Inspection Checklist for TEO-540-A1A Engines			
Engine Serial Number: _____ Engine Time: _____			
Date Inspection Done: _____ Inspection done by: _____			
Item	Comments	Findings/ Corrective Action	Done
Measure the ID of the crankshaft main bearings installed in the crankcase (Figure 13).		Front Main bearing measurement: _____ inches #2 Main bearing measurement: _____ inches #3 Main bearing measurement: _____ inches #4 Main bearing measurement: _____ inches	
Measure the OD of the crankshaft at the bearing locations.		Crankshaft at front main bearing measurement: _____ inches Crankshaft at #2 main bearing measurement: _____ inches Crankshaft at #3 main bearing measurement: _____ inches Crankshaft at #4 main bearing measurement: _____ inches	
Measure the ID of the camshaft bearing saddles formed by the crankcase when assembled.		Camshaft bearing saddle #1 measurement: _____ inches Camshaft bearing saddle #2 measurement: _____ inches Camshaft bearing saddle #3 measurement: _____ inches Camshaft bearing saddle #4 measurement: _____ inches	
Measure the OD of the camshaft at the camshaft bearing saddle locations.		Camshaft bearing saddle #1 measurement: _____ inches Camshaft bearing saddle #2 measurement: _____ inches Camshaft bearing saddle #3 measurement: _____ inches Camshaft bearing saddle #4 measurement: _____ inches	
Compare the difference between each crankshaft bearing ID and crankshaft OD measurement and the difference between each camshaft bearing saddle ID and camshaft OD measurement to the allowable clearance in the latest revision of the <i>Service Table of Limits - SSP-1776</i> .			

6. Crankshaft Inspection

- A. Before cleaning the crankshaft, initially examine the crankshaft trigger gear assembly and crankshaft inner diameter and external surface for evidence of pitting and wear. These conditions are of particular importance when they occur on the involutes of the crankshaft trigger gear assembly teeth. Replace the crankshaft trigger gear assembly if there is any pitting or wear.
- B. Clean the crankshaft per “Crankshaft Cleaning,” “Crankshaft Counterbore Cleaning,” and “Crankshaft Trigger Gear Assembly Cleaning” procedures in Chapter 05-30. Prior to inspection, the crankshaft counterbore must be clean, dry, and free of debris. Make a copy of the Crankshaft Inspection Checklist for TEO-540-A1A Engines to record the condition of the crankshaft and any corrective action.
- C. Clean the hollow inner diameter bore of the crankshaft (Figure 22) with mineral spirits, MIL-PRF-680 or equivalent or Stoddard Solvent. Prior to inspection, the crankshaft inner diameter must be clean, dry, and free of debris.
- D. Continue with the crankshaft inspection. Do not make scores, scratches, or etch markings of any kind on the crankshaft. A mark in any of these areas can cause the crankshaft to weaken and to possibly fail.

Crankshaft Inspection Checklist for TEO-540-A1A Engines			
Engine Serial Number: _____		Engine Time: _____	
Date Inspection Done: _____		Inspection done by: _____	
Item	Comments	Findings/ Corrective Action	Done
Carefully examine all surfaces of the crankshaft for cracks, gouges, nicks, dents, or damage.	If a crack is found, replace the crankshaft. <u>Do NOT try to repair a cracked or damaged crankshaft.</u>	Acceptable Replace	
Complete a magnetic particle inspection on the crankshaft.	Refer to the “Non-Destructive Testing” section in Chapter 05-50.	Acceptable Replace	
Examine the crankshaft bearing surfaces.	Refer to the “Crankshaft Bearing Surface Inspection” section in this chapter.		
Examine the counterbored mounting surface of the crankshaft for cracks, gouges, nicks, dents, or damage.	If a crack, gouge, nick, dent, or damage is found, replace the crankshaft. <u>Do NOT try to repair a cracked, gouged, nicked, dented, or damaged crankshaft counterbore.</u>		

Crankshaft Inspection Checklist for TEO-540-A1A Engines (Cont.)			
Item	Comments	Findings/ Corrective Action	Done
Use a flashlight, magnifying glass, and angled inspection mirror to visually examine the hollow inner diameter bore of the crankshaft bore (Figure 22), starting at the crankshaft flange end.	Replace a damaged or cracked crankshaft. Replace the crankshaft if there is any raised metal on surfaces. Replace the crankshaft if there is any scratch, ding, dent, or pit that exceeds 0.050 in. (1.27 mm) depth.	Acceptable Replace	
<div style="text-align: center;"> <p>EXPANSION PLUG STD-1211</p> <p>3.50 in. ±0.100 (8.89 cm ±0.25)</p> <p>1.25</p> <p>0.060 in. (1.524 mm) min. radius</p> <div style="border: 1px solid black; padding: 5px; display: inline-block;"> VISUAL INSPECTION NO PIT MARKS ON THESE SURFACES </div> </div> <p style="text-align: center;">Figure 22 Area to be Examined</p>			

Crankshaft Inspection Checklist for TEO-540-A1A Engines (Cont.)

⚠ CAUTION LYCOMING ENGINES NO LONGER APPROVES STRAIGHTENING OR GRINDING OF BENT CRANKSHAFT FLANGES TO RESTORE MAXIMUM RUN-OUT. IF THE CRANKSHAFT FLANGE IS BENT, REPLACE THE CRANKSHAFT. DO NOT TRY TO STRAIGHTEN OR GRIND THE CRANKSHAFT FLANGE. (REFER TO THE LATEST REVISION OF SERVICE BULLETIN NO. SB-201.)

Item	Comments	Findings/ Corrective Action	Done
Measure the crankshaft flange thickness and compare it with the dimensions in Figures 23 and 24 to calculate the minimum permissible thickness.	If the crankshaft flange is bent, replace the crankshaft. Do NOT straighten or grind a bent crankshaft. Refer to the latest revision of Service Bulletin No. SB-201 for any additional details.		
Crankshaft Flange Thickness			
Inches	Millimeters	Inches	Millimeters
0.440 ± 0.010	11.176 ± 0.254	0.420	10.668
Measure the run-out of the crankshaft flange with a dial indicator at the location shown in Figures 23 and 24. The maximum Total Indicator Reading (TIR) must not be more than 0.005 in. (0.127 mm). As shown in Figure 23, make sure that the pilot diameter runs true with the front and rear main bearings within 0.003 in. (0.076 mm).	If run-out exceeds 0.005 in. (0.127 mm) Total Indicator Reading, replace the crankshaft. Do not try to repair or grind a warped or bent crankshaft flange.		

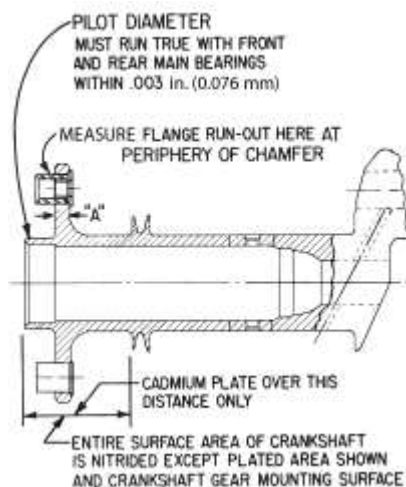


Figure 23
Crankshaft Flange

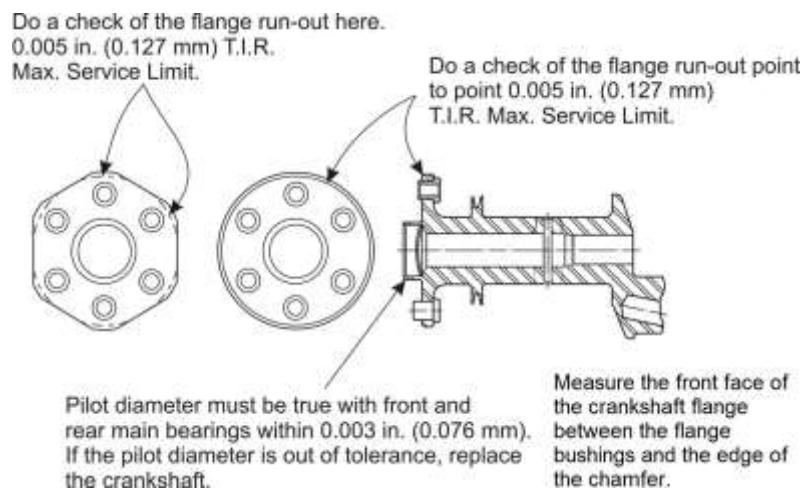


Figure 24
Crankshaft Flange Run-Out and Pilot Diameter

Crankshaft Inspection Checklist for TEO-540-A1A Engines (Cont.)

Crankshaft Trigger Gear Assembly Inspection

NOTICE: Any time the crankshaft gear bolt (Figure 25) is removed from the crankshaft trigger gear assembly, the bolt is to be discarded and replaced with a new bolt for the applicable crankshaft trigger gear assembly. The discarded bolt is not to be re-installed on any engine.

Do not remove the alignment dowel (Figure 25) from the end of the crankshaft unless it is damaged. Replace a damaged alignment dowel per the “Alignment Dowel Replacement” procedure in this chapter.

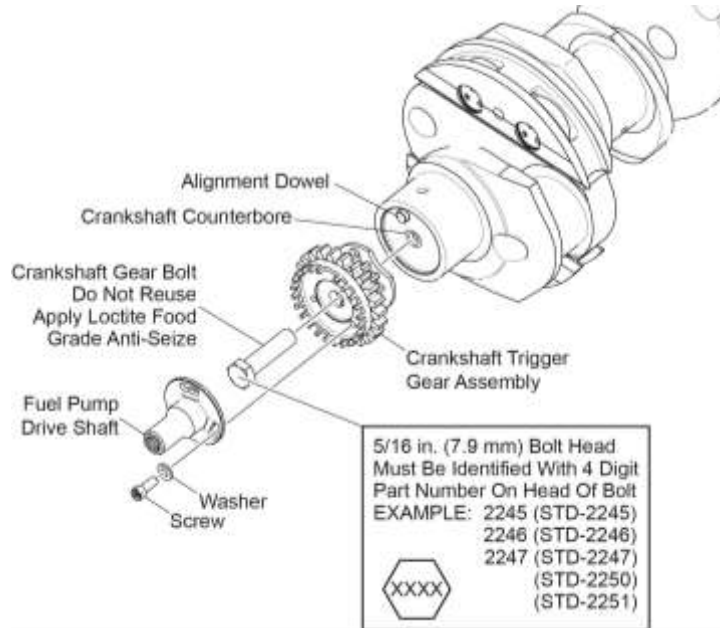


Figure 25
Crankshaft Trigger Gear Assembly and Crankshaft Gear Bolt

Item	Comments	Findings/ Corrective Action	Done
The crankshaft trigger gear assembly has three scallops (the larger scallops enable the shim check) as shown in Figure 26.			

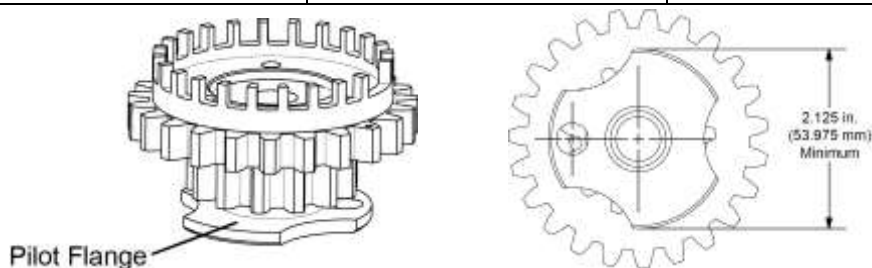




Figure 26
Crankshaft Trigger Gear Assembly

Crankshaft Inspection Checklist for TEO-540-A1A Engines (Cont.)			
Item	Comments	Findings/ Corrective Action	Done
Crankshaft Trigger Gear Assembly Inspection (Cont.)			
Measure the diameter of the crankshaft trigger gear assembly pilot flange (Figure 27).	If the diameter of the pilot flange is less than 2.125 in. (53.975 mm) do not install this gear on the crankshaft. Replace the crankshaft trigger gear assembly with a serviceable crankshaft trigger gear assembly.		
Measure dimensions on the crankshaft trigger gear assembly per those shown in Figure 27.		Acceptable Replace	
<p>Figure 27 Details for Crankshaft Trigger Gear Assembly</p>			
Examine the crankshaft trigger gear assembly for pitting and wear.	Replace a pitted or worn crankshaft trigger gear assembly.	Acceptable Replace	
Examine the pilot flange diameter of the crankshaft trigger gear assembly for damage from galling or fretting.	If the pilot flange of the crankshaft trigger gear assembly is damaged, replace the crankshaft trigger gear assembly.	Acceptable Replace	
If there is a hole, slot, or tang on the crankshaft trigger gear assembly, examine the hole, slot, or tang for nicks or dents.	If nicks or dents are found on the hole, slot, or tang, replace the crankshaft trigger gear assembly.	Acceptable Replace	
Examine the teeth of the crankshaft trigger gear assembly for nicks or deformities.	If there are nicks or deformities on the teeth of the crankshaft trigger gear assembly, replace the crankshaft trigger gear assembly with a new crankshaft trigger gear assembly (Figure 26).	Acceptable Replace	
Look for clearance between the mating surfaces of the crankshaft trigger gear assembly and crankshaft counterbore.	If there is any clearance when the crankshaft trigger gear assembly is installed, replace the crankshaft trigger gear assembly.	Acceptable Replace	
Complete a magnetic particle inspection of the crankshaft trigger gear assembly.	Refer to the "Non-Destructive Testing" section in Chapter 05-50.	Acceptable Replace	

Crankshaft Inspection Checklist for TEO-540-A1A Engines (Cont.)			
Item	Comments	Findings/ Corrective Action	Done
Criteria for Crankshaft Trigger Gear Assembly Replacement			
<p>Lycoming Engines no longer approves rework or repair of an unacceptable crankshaft trigger gear assembly. Replace the crankshaft trigger gear assembly with a serviceable crankshaft trigger gear assembly if any of the following are found during the crankshaft trigger gear assembly identification and inspection.</p> <ul style="list-style-type: none"> • If the pilot flange diameter is less than 2.125 in. (53.975 mm) or is not in compliance with dimensions shown in Figure 27 • If the crankshaft trigger gear assembly does not have the larger scallops as shown in Figure 26 • Damaged counterbore face of the crankshaft trigger gear assembly • If the crankshaft trigger gear assembly has a hole, slot, or tang and there are any nicks or dents on the hole, slot, or tang; nicks or deformities on the slot and teeth of the crankshaft trigger gear assembly • Pitting, galling, fretting, or wear • Crankshaft gear that fails magnetic particle inspection • Clearance between the mating surfaces of the installed crankshaft trigger gear assembly and crankshaft counterbore (There must not be any clearance when the crankshaft trigger gear assembly is installed.) 			
Crankshaft Counterbore Inspection			
<p> CAUTION LYCOMING ENGINES NO LONGER ALLOWS REWORK OF THE COUNTERBORE. DO NOT TRY TO REPAIR THE CRANKSHAFT COUNTERBORE THREADS IN THE FIELD. IF THIS TYPE OF REPAIR IS NECESSARY, IT IS RECOMMENDED THE CRANKSHAFT BE SENT TO THE FACTORY (THROUGH AN AUTHORIZED LYCOMING DISTRIBUTOR) WITH PAPERWORK THAT IDENTIFIES THE NECESSARY REPAIR.</p> <p>NOTICE: Prior to inspection, the crankshaft counterbore must be clean, dry, and free of debris. Refer to the “Crankshaft Counterbore Cleaning” procedure in Chapter 05-30.</p>			
Make sure the threads in the counterbored end of the crankshaft are intact and not galled, stripped, or damaged.	If the threads are galled, stripped or damaged, it is recommended the crankshaft be sent to Lycoming Engines (through an authorized Lycoming distributor) with paperwork that identifies the type of damage. Do not try to repair the threads in the field.		
Measure the Inside Diameter (ID) of the crankshaft counterbore at the rear of the crankshaft to make sure there is a correct fit between the ID of the crankshaft and the Outside Diameter (OD) of the crankshaft trigger gear assembly pilot flange. The crankshaft counterbore diameter at the rear of the crankshaft must not be more than 2.126 in. (54.000 mm) when measured at any location.	If the diameter is oversized, replace the crankshaft. Lycoming Engines no longer approves rework or repair of an unacceptable crankshaft counterbore diameter.		

Crankshaft Inspection Checklist for TEO-540-A1A Engines (Cont.)			
Item	Comments	Findings/ Corrective Action	Done
Examine the gear mounting face of the crankshaft counterbore.	If the mounting face of the crankshaft counterbore is damaged, replace the crankshaft.		
Examine and measure the alignment dowel per instructions in the "Alignment Dowel Inspection" in this chapter.			
Counterweight Inspection			
<p>Figure 28 Crankshaft Counterweight, Rollers, and Bushings</p>			
<p>NOTICE: A crankshaft counterweight (Figure 28) cannot be repaired. It only can be replaced.* A counterweight roller cannot be repaired. It only can be replaced as an identical paired set specific for each counterweight.*</p>			
Examine the surface of the counterweight for scoring, scratches, punch marks, or any other surface damage. Make sure the counterweight surface is smooth.	Replace the counterweight if there is scoring, scratches, punch marks, or any other surface damage or if the counterweight surface is not smooth. If one or more cracks are found on the counterweight, replace the counterweight*.	Outcome of Counterweight Position 1 inspection:	
		Accept Replace	
		Outcome of Counterweight Position 2 inspection:	
		Accept Replace	
Findings / Comments:			
*Refer to the latest revision of Service Instruction Nos. SI-1012 and SI-1535 for part numbers and instructions to replace counterweights and rollers.			

Crankshaft Inspection Checklist for TEO-540-A1A Engines (Cont.)			
Item	Comments	Findings/ Corrective Action	Done
Counterweight Inspection (Cont.)			
Examine the lug bushings (Figure 28) for roundness and for any scratches, etching, galling or any other surface damage.	Replace any lug bushing that is out-of-round, scratched, etched, galled, or has surface damage. Refer to the latest revision of Service Instruction No. SI-1142		
Complete Non-Destructive Testing (magnetic particle inspection) on the counterweights.	Refer to Chapter 05-50.	Findings / Comments:	
Examine the bushing bore on the counterweight for roundness and for any scratches, etching, galling or any other surface damage. Measure the bushing bore diameter on the counterweight.	Replace the counterweight if the bushing bore on the counterweight is not round, not smooth, is out of tolerance, or has surface damage.*	Outcome of Bushing Bore Inspection for Counterweight Position 1 Accept Replace	
		Outcome of Bushing Bore Inspection for Counterweight Position 2 Accept Replace	
The bushing bore on the counterweight must be between 0.9369 and 0.9377 in. (23.7973 and 23.8176 mm).		Bushing Bore Diameter Counterweight Position 1:	
		Bushing Bore Diameter Counterweight Position 2:	
NOTICE: If the bushing bore on the counterweight is not within the specified tolerances, replace the counterweight. Some counterweights must be replaced as a matched set.*			
 CAUTION DO NOT INCREASE THE DIAMETER OF THE BUSHING BORE ON A COUNTERWEIGHT. THIS ENLARGEMENT CAN CAUSE ENGINE DAMAGE BECAUSE IT WILL DECREASE THE SNAP RING GROOVE DEPTH IN THE BUSHING BORE ON THE COUNTERWEIGHT.			
Examine the surface of the rollers for scoring, scratches, punch marks, or any other surface damage. Make sure the roller surface is smooth.	If the roller surface is not smooth or has scoring, scratches, punch marks, or any other surface damage is on one or both rollers in a pair, replace the rollers as a matched pair.	Outcome of Roller Pair Inspection for Counterweight Position 1 Accept Replace	
		Outcome of Roller Pair Inspection for Counterweight Position 2 Accept Replace	
*Refer to the latest revision of Service Instruction Nos. SI-1012 and SI-1535 for part numbers and instructions to replace counterweights and rollers.			

Crankshaft Inspection Checklist for TEO-540-A1A Engines (Cont.)			
Item	Comments	Findings/ Corrective Action	Done
Counterweight Inspection (Cont.)			
Complete Non-Destructive Testing on rollers. Refer to Chapter 05-50.	If one or more cracks are found on a roller, replace the rollers as a matched pair.*	Findings / Comments:	
Measure the roller dimensions per the latest revision of Service Instruction No. SI-1535.	If the roller is out of tolerance, replace the rollers as a matched pair.*	Findings / Comments:	
Rejection Criteria for a Crankshaft			
A crankshaft must be replaced under any of the following conditions:			
<ul style="list-style-type: none"> • If a crack or damage is found • If corrosion is found or there is evidence of grinding to remove corrosion • Crack(s) or pitting with crack(s) in the crankshaft inner bore • Warped or bent crankshaft flange (Do not try to repair or grind a warped or bent crankshaft flange) • If the mounting surface of the crankshaft counterbore is galled, fretted or damaged • Oversized inside diameter of the crankshaft, greater than 2.126 in. (54.000 mm) • If a bearing surface is scored, galled, or worn and polishing to 0.003 in. or 0.006 in. undersize does not remove the condition • If the undersize is greater than 0.006 in. • Raised metal on surfaces, including inner diameter bore of crankshaft. • Scratch, ding, dent, or pit that exceeds 0.050 in. (1.27 mm) depth on crankshaft inner diameter bore • If run-out exceeds 0.005 in. (0.127 mm) Total Indicator Reading (TIR) 			
Findings/Comments:			
*Refer to the latest revision of Service Instruction Nos. SI-1012 and SI-1535 for part numbers and instructions to replace counterweights and rollers.			

E. Alignment Dowel Inspection

- (1) Examine the alignment dowel installed in the end of the crankshaft.
- (2) Make sure the alignment dowel is perfectly smooth and round, without nicks, cracks, or deformation.
- (3) Make sure that the end of the dowel is 0.160 in. +/- 0.010 in. (4.06 mm +/- 0.254 mm) above the counterbore surface of the crankshaft as shown in Figure 29.
- (4) Make sure the alignment dowel fits tightly in the crankshaft. It must not spin or be loose.

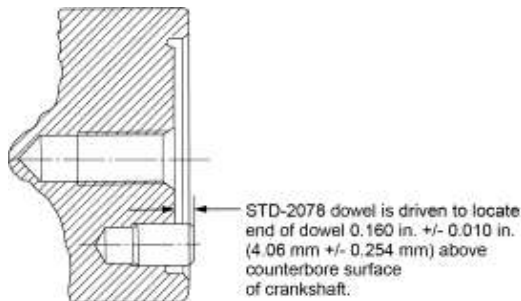


Figure 29

Section Through Counterbore End of Crankshaft Showing Driven Height of Dowel

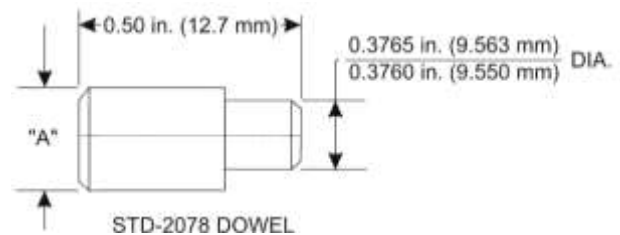


Figure 30

Details of Crankshaft Dowel

- (5) Measure the diameter of the alignment dowel (Dimension A) shown in Figure 30 and determine if the measurement conforms to the values for the different alignment dowel part numbers in the latest revision of Service Bulletin No. SB-475.
- (6) If the alignment dowel is out of tolerance or out of round, replace the dowel with a new one per the "Alignment Dowel Replacement" procedure in this chapter.


7. Crankshaft Bearing Surface Inspection

- A. Examine all bearing surfaces for scoring, galling, gouges, and wear. If a bearing surface is scored, galled, or worn and polishing to either 0.003 in. or 0.006 in. undersize does not remove the condition, replace the crankshaft.
- B. Refer to the latest revision of the *Service Table of Limits - SSP-1776* to identify the nominal manufactured specifications of the bearing journals. Undersize crankshaft bearing journals in Table 1 are identified by a code symbol stamped on the front of the flange as a suffix to the part number.

Table 1
Crankshaft Undersize Codes

Journals	0.003 in.	0.006 in.
Main Bearing Journals	M03M	M06M

- C. Using a micrometer, measure and record the dimensions.
- D. If the actual undersize is between the service limit (0.0015 in. and 0.003 in.), complete the following:
 - (1) Polish to 0.003 in. undersize.
 - (2) Fit with 0.003 in. bearing insert.
 - (3) Repeat for all bearings.

 **CAUTION** DURING POLISHING, DO NOT ALLOW THE LATHE SPEED TO EXCEED 150 RPM.

NOTICE: Polishing undersize is preferable to grinding undersize because crankshafts that are polished do not require re-nitriding.

If one bearing journal is polished to 0.003 in. or 0.006 in. undersize, all corresponding journals must be polished to the same size.

If a bearing surface is scored, galled, or worn and polishing to either 0.003 in. or 0.006 in. undersize does not remove the condition, replace the crankshaft.

E. If, after the bearing journal is polished to 0.003 in., the bearing journal requires more polishing complete the following:

- (1) Polish to 0.006 in. undersize.
- (2) Fit with 0.006 in. bearing insert.
- (3) Repeat for all like bearings.

F. If the actual undersize is greater than 0.006 in., replace the crankshaft.

8. Bearing Shell Surface Inspection

NOTICE: Inspections in this section refer to reusable items that do not require replacement in accordance with the latest revision of Service Bulletin No. SB-240. Be sure to record any part replacement or corrective action in the engine logbook.

- A. Examine all bearing saddle surfaces for scoring, galling, gouges, and wear. If any of these conditions are found, identify and correct the cause.
- B. Make sure that the clearance of each bearing agrees with the specification in the latest revision of the *Service Table of Limits - SSP-1776*.
- C. If a bearing does not conform to the specified limits in the latest revision of the *Service Table of Limit - SSP-1776*, discard it and replace it with a new one.
- D. Examine all journal surfaces for galling, scores, misalignment, and out-of-round condition. Replace a scored, galled, misaligned, or out-of-round component.
- E. Examine the shafts and pins for straightness.

9. Gear Inspection

- A. Examine the involutes of the gear teeth for pitting and excessive wear.
- B. If pit marks or wear are found, discard the gear and replace it with a new one.
- C. Examine the bearing surfaces of all gears for deep scratches.
- D. Remove minor abrasions with a fine abrasive cloth.

10. Screwed Fitting Inspection

- A. Examine the condition of the threads on screwed fittings (threaded fastenings or plugs).
- B. Remove small nicks and burrs with a small file, fine abrasive cloth, or stone.
- C. If the part cannot be repaired by polishing it, discard it and replace it with a new one.
- D. If the part has too much distortion, galling, or mutilation (caused by over-tightening or use of an incorrect tool), replace it with a new part. Do not re-use a non-conforming part.

11. Camshaft Disassembly and Inspection

Remove and discard the spacer and retaining ring from the camshaft (Figure 31).

There are two parts to the camshaft inspection: a visual inspection and a dimensional inspection.

Copy and complete the Camshaft Inspection Checklist to do the camshaft inspection.

NOTICE If a new or reconditioned camshaft is to be installed, install new tappet bodies. Refer to the “Camshaft Replacement Guidelines” section in the latest revision of Service Instruction No. SI-1011 for guidelines on replacing the camshaft when new tappets are installed in the engine.

If a hydraulic tappet body has been rejected for spalling, carefully examine the corresponding camshaft lobe for evidence of distress, surface irregularity, or feathering on the edges.

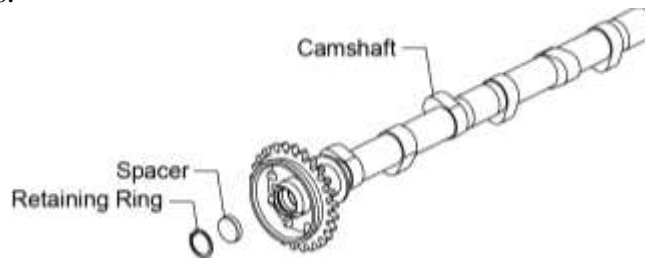
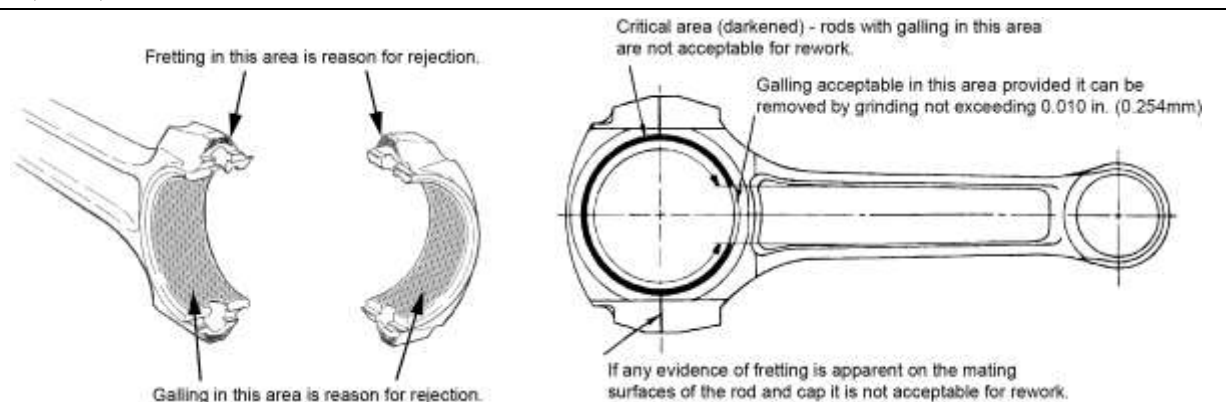


Figure 31
Camshaft with Integral Gears

Camshaft Inspection Checklist for TEO-540-A1A Engines			
Item	Comments	Findings/ Corrective Action	Done
Camshaft Visual Inspection			
Visually examine all surfaces of the camshaft (Figure 31) – give particular attention to bearing surfaces and camshaft lobes. If any of the following conditions are found during this visual inspection, replace the camshaft: cracks, scoring, galling, corrosion, pitting, feathering (at edge of camshaft lobes or bearing), surface irregularity, distress/fatigue, or other damage			
Camshaft	Acceptable (No crack, scoring, galling, corrosion, pitting, feathering (at edge of camshaft lobes or bearing), surface irregularity, distress/fatigue, or other damage)		
	Replace Comment- condition(s) found:		
Camshaft Dimensional Inspection			
Support the camshaft in V-blocks and measure the run-out. Refer to the latest revision of the <i>Service Table of Limits - SSP-1776</i> . If the run-out is out of tolerance, replace the camshaft.	Run-out measurement:	Acceptable Replace	
Measure the OD of the camshaft at the bearing locations and compare the results to the bearings formed by the crankcase (per the “Crankcase Dimensional Inspection” in this chapter.) If the OD is not within limits, replace the camshaft.		Acceptable Replace	

12. Connecting Rod Inspection

Copy the Connecting Rod Inspection Checklist for TEO-540-A1A Engines to record the condition of all of the connecting rods and any corrective action.

Connecting Rod Inspection Checklist for TEO-540-A1A Engines						
Engine Serial Number: _____		Engine Time: _____				
Date Inspection Done: _____		Inspection done by: _____				
Clean the connecting (Figure 33) rod and its cap thoroughly with mineral spirits. Visually examine the connecting rod for damage. Replace a damaged connecting rod.						
Task or Inspection	Findings and/or Corrective Action					
	Cyl. 1	Cyl. 2	Cyl. 3	Cyl. 4	Cyl. 5	Cyl. 6
Examine the connecting rod bore for wear. If the rod bore (Figure 32) is worn, replace the connecting rod assembly.	Acceptable Replace	Acceptable Replace	Acceptable Replace	Acceptable Replace	Acceptable Replace	Acceptable Replace
Examine the mating face of the connecting rod and its cap face for fretting (Figure 32). If fretting is found, replace the connecting rod assembly.	Acceptable Replace	Acceptable Replace	Acceptable Replace	Acceptable Replace	Acceptable Replace	Acceptable Replace
Use a 6-power magnifying glass (minimum) or bench microscope to examine the critical areas on the connecting rod identified in Figure 32 for galling.* If galling is found in areas in Figure 32, replace the connecting rod assembly.	Acceptable Replace	Acceptable Replace	Acceptable Replace	Acceptable Replace	Acceptable Replace	Acceptable Replace
* Do not mistake stains or discoloration for galling. Surface blemishes are easily removed with a fine abrasive cloth, chemical cleaner or steel wool. Whereas, galling cannot be removed. If galling is found in the bearing bore, replace the connecting rod. If surface blemishes cannot be removed with a fine abrasive cloth, chemical cleaner or steel wool, there is evidence of galling. Gall marks vary in size and shape. Some gall marks can be as small as pin heads. Other gall marks can be circular, oval, thin, or look like rods.						
						
Figure 32 Areas on Connecting Rod to Examine for Fretting and Galling						

Connecting Rod Inspection Checklist for TEO-540-A1A Engines (Cont.)				
Item	Comments	Findings/ Corrective Action		Done
Examine the connecting rod bushing for damage.	Replace a damaged connecting rod bushing.	Connecting Rod 1		
		Connecting Rod 2		
		Connecting Rod 3		
		Connecting Rod 4		
		Connecting Rod 5		
		Connecting Rod 6		
Examine the Connecting Rod Bushing for Wear:				
<p>(1) Measure and record the Inside Diameter (ID) of the connecting rod bushing.</p> <p>(2) Measure and record the Outside Diameter (OD) of the piston pin.</p> <p>(3) Calculate and record the clearance by subtracting the OD of the piston pin from the ID of the connecting rod bushing.</p> <ul style="list-style-type: none"> If the clearance is less than or equal to the “Service Max.” clearance in the latest revision of the <i>Service Table of Limits - SSP-1776</i>, the connecting rod bushing and piston pin are acceptable with regards to connecting rod bushing wear. If the clearance is greater than the “Service Max.” clearance in the latest revision of the <i>Service Table of Limits - SSP-1776</i>, remove, discard and replace the component(s) that exceed(s) the manufacturing dimensions according to the latest revision of the <i>Service Table of Limits - SSP-1776</i>. <p>(4) If the connecting rod bushing is damaged or out of tolerance, complete the “Connecting Rod Bushing Replacement” procedure in this chapter.</p>	Connecting Rod 1	Acceptable	Replace	
	Connecting Rod 2	Acceptable	Replace	
	Connecting Rod 3	Acceptable	Replace	
	Connecting Rod 4	Acceptable	Replace	
	Connecting Rod 5	Acceptable	Replace	
	Connecting Rod 6	Acceptable	Replace	

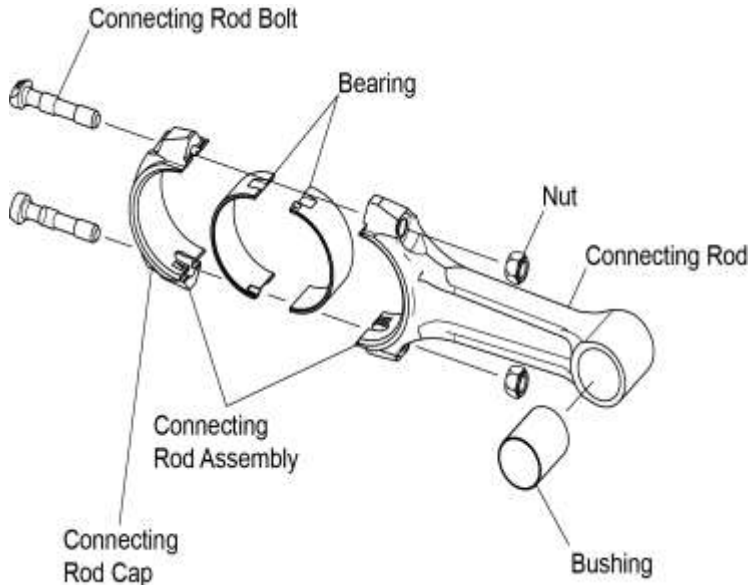
Connecting Rod Inspection Checklist for TEO-540-A1A Engines (Cont.)


Figure 33
Connecting Rod

For connecting rods that pass the Visual Inspection herein, complete a Magnetic Particle Inspection on all connecting rods as per the “Non-Destructive Testing” section in Chapter 05-50.

Findings/ Corrective Action of Magnetic Particle Inspection

Connecting Rod 1	Acceptable Replace
Connecting Rod 2	Acceptable Replace
Connecting Rod 3	Acceptable Replace
Connecting Rod 4	Acceptable Replace
Connecting Rod 5	Acceptable Replace
Connecting Rod 6	Acceptable Replace

Complete the “Connecting Rods- Parallelism/ Squareness Check” in this chapter.

For the parallelism check, measure the distance between arbors (Figure 37). For exact parallelism or alignment, the distances measured on both sides are to be the same. For the squareness check, use a feeler gage to measure the clearance at the four check points where the arbors rest on the parallel blocks (Figure 38). Compare the clearance between each arbor and the parallel blocks against the values in the latest revision of the *Service Table of Limits - SSP-1776*. If out of tolerance, replace the connecting rods and examine the crankshaft to make sure the crankshaft is not damaged.

Connecting Rod	Parallelism Measurement	Squareness Measurement	Outcome
Connecting Rod 1			Acceptable Replace
Connecting Rod 2			Acceptable Replace
Connecting Rod 3			Acceptable Replace
Connecting Rod 4			Acceptable Replace
Connecting Rod 5			Acceptable Replace
Connecting Rod 6			Acceptable Replace

Connecting Rod Inspection Checklist for TEO-540-A1A Engines (Cont.)

Connecting Rod Bearing and Crankshaft Clearance

To complete this inspection:

NOTICE: For this inspection, the connecting rods, bearings, connecting rod bolts, and nuts (Figure 33) are assembled, but not installed on the crankshaft.

All of the connecting rods installed on the crankshaft must be of the same weight class, except “S” weight rods (service rods) can be used with either “A” or “E” weight rods depending on parts availability. Record the weight code of each connecting rod in this checklist.

- (1) Assemble and torque each connecting rod with new bearings per instructions in the “Connecting Rod Installation” section in this chapter.
- (2) Measure the inside diameter of the bearing in each connecting rod and record the measurement in this checklist.
- (3) Measure the crankshaft diameter at the crank pin journal for each connecting rod and record the measurement in this checklist.
- (4) Subtract the crankshaft diameter at the crank pin journal from the inside diameter of the bearings for each connecting rod to calculate the connecting rod bearing and crankshaft clearance. Record the measurement in this checklist.
- (5) Compare the connecting rod bearing and crankshaft clearance to the acceptable clearance measurement in the latest revision of the *Service Table of Limits - SSP-1776*.
- (6) Remove and discard the connecting rod bolts and nuts from the connecting rod assembly.
- (7) If the connecting rod bearing and crankshaft clearance is within limits, the connecting rod bearings are acceptable.
- (8) If the connecting rod bearing and crankshaft clearance is not within limits, replace the connecting rod bearings with oversize bearings to bring the clearance within acceptable limits.

Connecting Rod Inspection Checklist for TEO-540-A1A Engines (Cont.)

Connecting Rod	Connecting Rod Weight Code	Inside Diameter of the Bearings	Crankshaft Diameter at the Crank Pin Journal	Connecting Rod Bearing and Crankshaft Clearance	Outcome
Connecting Rod 1					Acceptable Replace
Connecting Rod 2					Acceptable Replace
Connecting Rod 3					Acceptable Replace
Connecting Rod 4					Acceptable Replace
Connecting Rod 5					Acceptable Replace
Connecting Rod 6					Acceptable Replace

13. Connecting Rod Bushing Replacement

NOTICE: Replace the connecting rod bushing if it is damaged or if the inner diameter of the bushing is worn beyond service limit per the Connecting Rod Inspection Checklist for TEO-540-A1A Engines.

- A. Clamp the connecting rod on the Connecting Rod Bushing Replacement Block (P/N 64597) in such a manner that the small bushing in the rod is in alignment with the hole stamped "Remove Bushing".
- B. Use the Connecting Rod Bushing Removal Drift (P/N 64535) to drive the bushing out of the rod.
- C. Move the connecting rod to the "Install and Burnish" position and clamp it securely in place.
- D. Use the Replacement Drift (P/N 64536) to install the new connecting rod bushing where shown in the connecting rod (Figure 33).

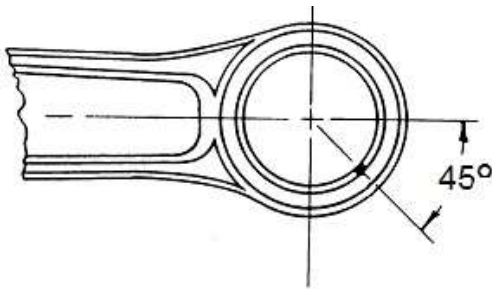


Figure 34

Bushing Installed in the Connecting Rod

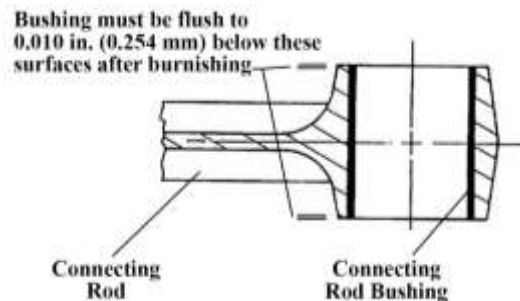


Figure 35

Bushing Burnished Flush to 0.010 in. (0.254 mm) Below Connecting Rod Surface

- E. Make sure the split in the bushing is located so that it is toward the piston end of the connecting rod and 45° off the centerline (Figure 34) and press the bushing into the connecting rod until the edge of the bushing is flush with the surface of the connecting rod.
- F. Use a suitable arbor press and the Connecting Rod Bushing Burnisher (P/N 64580) to burnish the bushing in place.
- G. Pass the burnisher completely through the bushing.
- H. Examine the bushing after burnishing to make sure the bushing is flush to 0.010 in. (0.254 mm) below the connecting rod surface (Figure 35) on both sides of the connecting rod.
- I. Remove the connecting rod from the holding block and complete a final bore of the bushing to the diameter shown in the latest revision of the *Service Table of Limits - SSP-1776*.
- J. As a check, measure the bushing inner diameter with the Finish ID Gage (P/N 64767).
- K. Complete the "Connecting Rod Parallelism/Squareness Check" in this chapter.
- L. If the assembly does not pass this check, replace the connecting rod assembly.
- M. Record replacement of the connecting rod bushing in the engine logbook.

14. Connecting Rod - Parallelism / Squareness Check

NOTICE: The Connecting Rod Parallelism and Squareness Gage P/N 64530 (Figure 36) is necessary for this check.

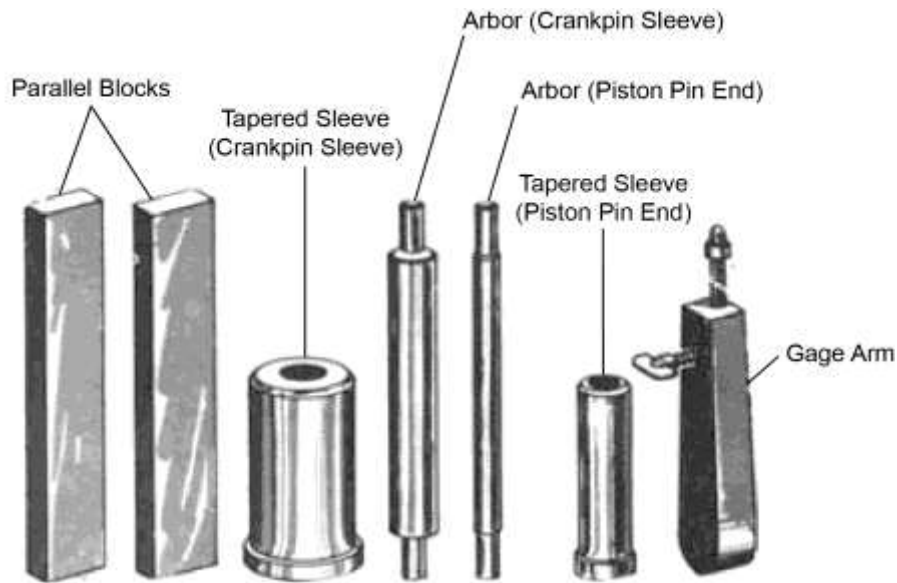


Figure 36
Connecting Rod Parallelism and Squareness Gage P/N 64530

- A. Make sure that the bearing cap is assembled correctly and is tightened securely.
- B. Insert the tapered sleeves (Figure 37) of the Connecting Rod Parallelism and Squareness Gage P/N 64530 in the bearing holes in the connecting rod.
- C. Pull the arbors through the sleeves.
- D. Install the gage arm on the arbor as shown in Figure 37.
- E. Turn the adjusting screw on the gage arm until it just touches the arbor.
- F. Use the wing nut to lock the adjusting screw.
- G. Make sure the adjusting screw just touches the arbor.
- H. Remove the gage arm and install it on the other end of the arbor.
- I. Measure the distance between arbors. For exact parallelism or alignment, the distances measured on both sides must be the same. Record the parallelism measurement in the Connecting Rod Inspection Checklist for TEO-540-A1A Engines earlier in this chapter.
- J. Remove the gage arm.
- K. Keep the sleeves and arbors in place.
- L. Put the parallel blocks (Figure 38) of the Connecting Rod Parallelism and Squareness Gage on the surface plate.
- M. Put the ends of the arbors on the parallel blocks.

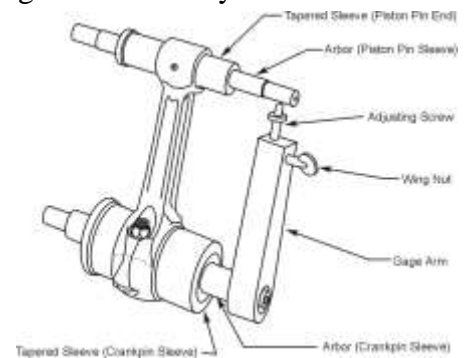


Figure 37
Parallelism Check of Connecting Rods

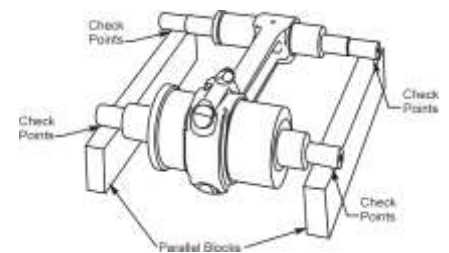


Figure 38
Squareness Check of Connecting Rods

- N. For the squareness check, use a feeler gage to measure the clearance at the four check points where the arbors rest on the parallel blocks (Figure 38). Record the measurement in the Connecting Rod Inspection Checklist for TEO-540-A1A Engines earlier in this chapter
- O. Compare the clearance between each arbor and the parallel blocks against the values in the latest revision of the *Service Table of Limits - SSP-1776*. If out of tolerance, replace the connecting rod and examine the crankshaft to make sure the crankshaft is not damaged.

15. Tappet Inspection

Remove and examine roller tappets (Figure 39) for integrity and free rotation of the roller which are acceptable to return in-use roller tappets to service.

NOTICE: Roller tappets are not field repairable and are not to be disassembled for parts re-use. Roller tappets are to be replaced if damaged or not operating correctly with a serviceable tappet. Replace all of the roller tappets as a complete set under any of the following circumstances:

- During overhaul
- If the engine operation time is close to TBO
- During engine disassembly after a propeller strike, sudden engine stoppage or metal contamination.

Refer to the latest revisions of Service Instruction Nos. SI-1011 and SI-1514.

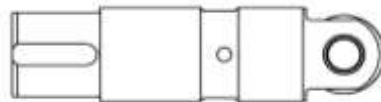


Figure 39
Hydraulic Roller Tappet

16. Crankshaft Assembly

A. Alignment Dowel Replacement

- (1) Use a center punch to mark the center of the exposed surface of the installed alignment dowel (Figure 40).
- (2) Mark a 1/8 in. drill bit to limit the depth of the drilled hole to 0.6 in. (15.14 mm).

⚠ CAUTION USE CARE NOT TO DRILL DEEPER THAN THE MARKED DEPTH LIMIT OF THE DRILL. DO NOT LET THE DRILL MAKE CONTACT WITH THE REAR OF THE CRANKSHAFT.

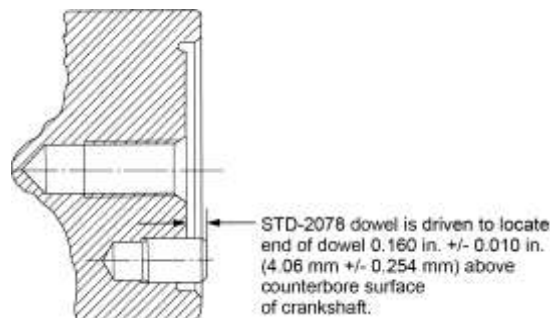


Figure 40

Section Through Counterbore End of Crankshaft Showing Driven Height of the Dowel

- (3) Drill a 1/8 in. diameter hole through the center of the installed alignment dowel.
- (4) Fill the new drilled hole with oil.
- (5) Put a piece of 1/8 in. diameter drill rod in the drilled hole.
- (6) Use a hammer or mallet to hit the end of the drill rod.
- (7) Hydraulic pressure from the oil will push out the alignment dowel from the crankshaft.
- (8) Remove and discard the alignment dowel.
- (9) Examine the bottom of the alignment dowel hole to make sure that the drill bit did not make contact with the bottom of the hole. If the drill bit made contact with the bottom of the hole, send the crankshaft to the factory for evaluation.
- (10) Press the replacement alignment dowel into the alignment dowel hole to the required driven height. Refer to Figure 40 for the alignment dowel part number and the correct driven height.

B. Crankshaft Trigger Gear Assembly Fit Verification

- (1) Start with a clean crankshaft that passed the “Crankshaft Inspection” in this chapter.
- (2) Make sure the mating surfaces of the crankshaft trigger gear assembly and crankshaft counter-bored end are clean and dry and that there is no debris. Refer to the procedures “Crankshaft Cleaning,” “Crankshaft Counterbore Cleaning,” and “Crankshaft Trigger Gear Assembly Cleaning” in Chapter 05-30 in this manual.
- (3) Install the crankshaft trigger gear assembly on the alignment dowel of the crankshaft counter-bored end as shown in Figure 41. Use a soft mallet as needed to seat the gear in place.
- (4) Make sure the crankshaft trigger gear assembly seats firmly and is perpendicular (not at a slanted angle) to the crankshaft as shown in Figure 42. If the crankshaft trigger gear assembly does not seat correctly, remove it, check for the cause, or replace the crankshaft trigger gear assembly if necessary.
- (5) Remove the crankshaft trigger gear assembly and put it in a safe place until it is installed, after the crankcase is assembled.

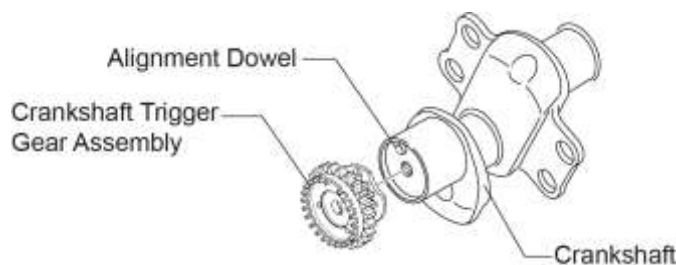


Figure 41
Crankshaft Trigger Gear Assembly

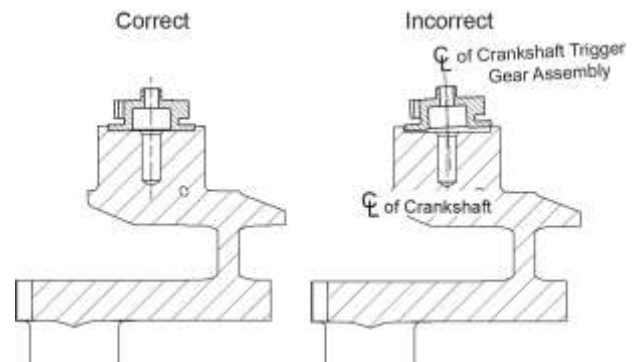


Figure 42
Crankshaft Trigger Gear Assembly Position

C. Expansion Plug Installation

NOTICE: If a constant speed propeller is used, there is no need to install an expansion plug. Otherwise, a new expansion plug is necessary for this procedure. Refer to the *TEO-540-A1A Illustrated Parts Catalog* for the part number.

- (1) Remove any remaining gasket maker from the crankshaft flange with an acetone-soaked wipe.

NOTICE: Make sure the surface is clean and that there is no debris or remaining gasket maker to ensure a good seal when the new bead of gasket maker is applied in the next step.

- (2) Apply a bead of Loctite® #2 Non-Hardening Gasket Maker or equivalent to the perimeter of a new expansion plug.
- (3) Seat the new expansion plug firmly on the shoulder in the bottom of the crankshaft bore with the convex side out (Figure 43).

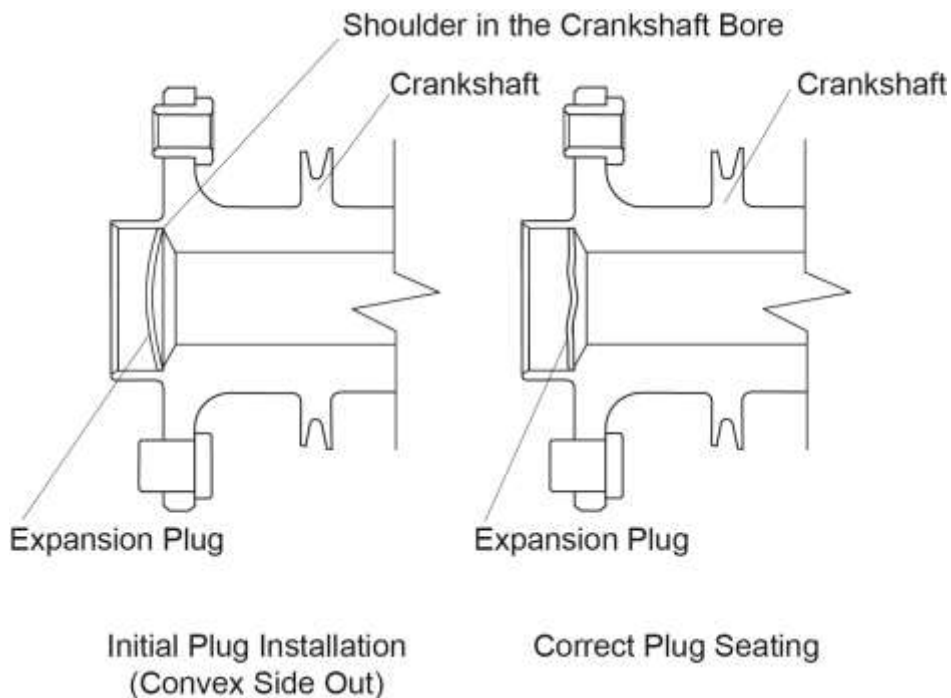


Figure 43
Installed Expansion Plug

NOTICE: A driver and a press table can be used to press the expansion plug in the crankshaft bore.

- (4) Install a Crankshaft Welch Plug Driver P/N 64681 against the expansion plug and strike the end of the driver with a hammer until the expansion plug is correctly seated (Figure 43) in the crankshaft bore.
- (5) Remove excess gasket material with a clean cloth soaked with acetone.

D. Solid-Ring Crankshaft Oil Seal Installation

NOTICE: If necessary, a crankshaft oil seal can be replaced with the engine assembled and installed in the airframe. Refer to the latest revision of Service Instruction No. SI-1324 for instructions for crankshaft oil seal removal, seal bore cleaning, and crankshaft oil seal installation on an installed engine.

NOTICE: Install a *new* crankshaft oil seal during crankshaft assembly. There are two types of crankshaft oil seals: a split oil seal (Figure 44) and the solid-ring crankshaft oil seal (with an internal spring) (Figure 45). The split oil seal is open for easy assembly around the crankshaft. The solid-ring crankshaft oil seal has more elasticity and can be stretched over the crankshaft propeller flange. The solid-ring crankshaft oil seal can be installed on the crankshaft *before* or *after* the crankshaft is installed in the crankcase. The split oil seal is installed *after* the crankshaft is installed in the crankcase per the “Crankshaft Oil Seal Installation” procedure later in this chapter.



Figure 44
Split Oil Seal



Figure 45
Solid-Ring Crankshaft Oil Seal

NOTICE: An oversize crankshaft oil seal could be necessary if the crankcase bore size was increased. Part numbers for oversized parts include a “P” suffix, such as –P50 and are identified on the face of the seal. Except for the revised outside diameter of the seals, the oversize seals are identical in other aspects to the standard size seals. For correct sealing, remove all traces of the oil sealant and oil from the crankcase before installation of a new crankshaft oil seal.

- (1) If not already done, complete the “Starter Ring Gear Support Removal” procedure in Chapter 72-70.
- (2) Examine the propeller flange, crankshaft sealing surface, and the crankcase seal bore recess for any scratches or nicks that damage or cause the seal to leak; if scratches or nicks are found, remove them with fine emery cloth (150 to 220-grit for very light metal sanding) or equivalent small fine abrasive stone. Remove any residue.

⚠ CAUTION IF MEK IS USED IN THE NEXT STEP, ONLY APPLY MEK TO THE CRANKCASE, INCLUDING THE CRANKCASE BORE AND GROOVE FOR THE CRANKSHAFT OIL SEAL. DO NOT APPLY MEK TO THE CRANKSHAFT OIL SEAL SINCE MEK CAN CAUSE THE SEAL TO DETERIORATE. BE SURE THAT ALL TRACES OF MEK OR ANY CLEANING SOLVENT, OIL, AND SEALANT ARE REMOVED PRIOR TO INSTALLATION OF A NEW CRANKSHAFT OIL SEAL.

- (3) Clean the recess/crankcase bore (which has the groove for the crankshaft oil seal), use a clean disposable lint-free cloth and any of the following cleaning solvents to remove oil, sealant, and debris from the crankcase, especially the crankcase bore:
- Methyl-Ethyl-Ketone (MEK)
 - Napasco SC-200
 - M-114.
 - Acetone
 - M-17
- (4) Locate and remove the internal spring from the solid-ring crankshaft oil seal to prevent damage to the spring, seal, and potential injury (Figures 46 and 47).



Figure 46
Locating the Internal Spring



Figure 47
Internal Spring Removed

- (5) Open the spring:
- (a) Find the spring joining ends.
 - (b) Hold the spring tightly in your left hand so it cannot turn (Figure 48).
 - (c) Twist the spring and roll your fingers counter-clockwise with your right hand about five turns to unthread and separate the spring ends.



Figure 48
Separating the Spring Threaded Ends

NOTICE: There are two types of internal springs used in the solid-ring crankshaft oil seal. One type has a hook on each end; the hooks are joined together. The other type has threaded ends; one end will be screwed into the other end.

- (6) Apply a thin film of Lubriko® M-6 Grease, engine oil, or equivalent on the sealing surface of the seal, around the crankshaft at the sealing surface and on the outer edge of the crankshaft flange (Figure 49).



Figure 49

Apply Lubriko® M-6 Grease, Engine Oil or Equivalent Around the Crankshaft and Crankshaft Flange

- NOTICE:** If available, a Pinion Cage Oil Retaining Housing P/N 67394 or 68293 can be installed on the crankshaft propeller flange (Figure 50) for easier installation of the solid-ring crankshaft oil seal.

In cold environments, pre-warm the seal to ease installation.

- (7) Put a brass pin approximately 9/32 in. diameter by 3 in. (7 cm) long through the crankshaft propeller flange bushing to hold both sides of the seal in place as shown in Figure 51.



Figure 50

Pinion Cage Oil Retaining Housing Installed on the Crankshaft Propeller Flange as a Guard

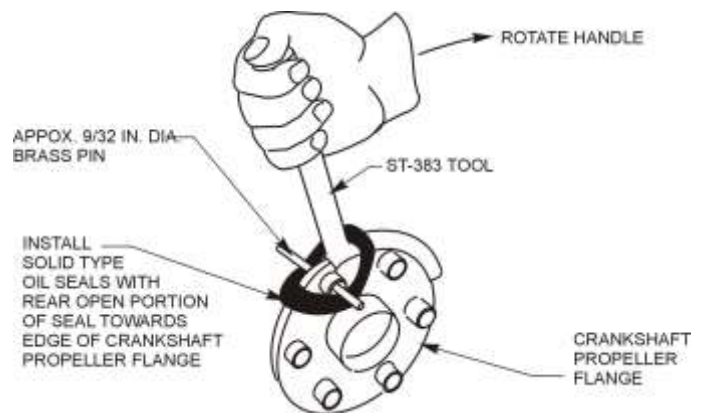


Figure 51

Crankshaft Propeller Flange Showing the Installation of the Solid-Ring Oil Seal

- (8) Install the oil seal over the edge of the crankshaft propeller flange with the groove (open portion) of the seal towards the crankshaft propeller flange. Refer to Figure 50.
- (9) Install the Crankshaft Oil Seal Installation Tool ST-383 under the seal and over the edge of the crankshaft propeller flange as shown in Figure 51. Use even pressure with your hand, carefully turn the tool to force the oil seal over the crankshaft propeller flange and use care not to damage the seal.

- (10) Install the internal spring as follows:
- (a) Position the spring between the seal and the oil slinger.
 - (b) Firmly hold the spring ends, one in each hand, and gently stretch the spring around the crankshaft behind the installed solid ring crankshaft oil seal (Figure 20).
 - (c) Twist the right side of the spring counter-clockwise three turns and hold.
 - (d) Twist the left side of the spring clockwise three turns and hold.
 - (e) Join the two spring ends together. Gently release the tension allowing the spring ends to thread into each other locking the spring together. Let the spring relax and rest behind the seal. The spring must be a continuous circle around the crankshaft with no kinks or twists.
 - (f) Work the spring into position in the groove (open portion) in the rear side of the solid-ring crankshaft oil seal.
 - (g) Ensure the spring is not damaged and is seated completely in the internal groove of the solid-ring crankshaft oil seal.
- (11) Use ethyl alcohol and disposable wipes to clean the outer surface of the seal and the crankcase seal bore recess.

NOTICE: The oil seal installation procedure is completed after the crankcase halves are joined together. Refer to the latest revision of Service Instruction No. 1324 for any new details.

E. Connecting Rod Installation

NOTICE: Each connecting rod is identified by a letter (A, E, S, etc.), stamped on the edge of the connecting rod beam, as a designation for weight class. All of the connecting rods installed on the crankshaft must be of the same weight class, except “S” weight rods (service rods) can be used with either “A” or “E” weight rods depending on parts availability.

- (1) Ensure that all of the connecting rods have the same weight class letter.
- (2) Apply specified lubricant to the connecting rod and bearing inserts per the latest revision of Service Instruction No. SI-1059 where shown in Figure 52. Different lubricants are used on the various areas on the connecting rod and bearing surfaces.

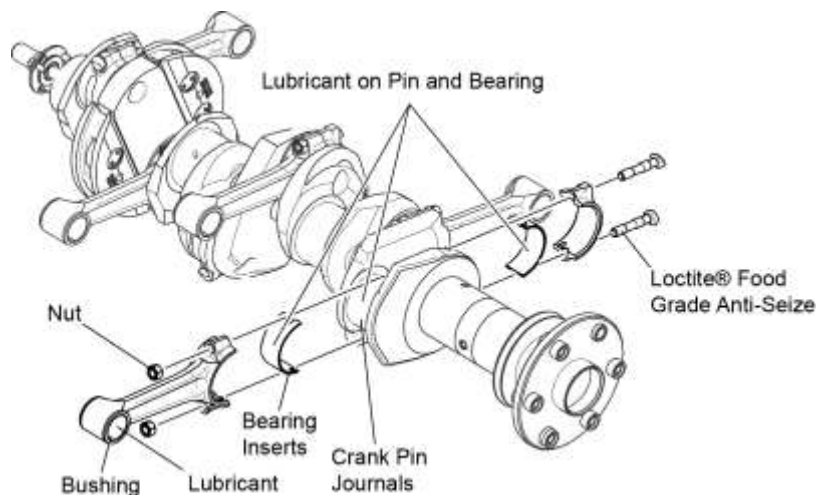



Figure 52
Connecting Rod Assembly Lubrication

NOTICE: Anytime either the connecting rod bolt and/or nut pairs are removed from a Lycoming engine, replace **both** the bolt and nut pairs with new “Service Use Only” hardware regardless of apparent condition.

- (3) Refer to the latest revision of Service Instruction No. SI-1458 or the *TEO-540-A1A Illustrated Parts Catalog* to identify the correct P/Ns for the new connecting rods bolts and nuts.
- (4) Make sure the new connecting rod bolt and new nut pairs are clean, free of dirt and debris and that the threads are not damaged.
- (5) Install the new lubricated matched set bearing pair on each connecting rod, one bearing on the connecting rod and the other bearing on the connecting rod cap. Ensure that the tang of each bearing fits and seats within the slot of the connecting rod as well as the connecting rod cap.

NOTICE: Do not install standard size connecting rod bolts in connecting rods with oversize bolt holes.

- (6) Apply Loctite® Food-Grade Anti-Seize Lubricant or equivalent to the bottom two or three threads of the new connecting rod bolts (Figure 52). Wipe away excess lubricant with a clean, lint-free cloth.
- (7) Apply engine oil mixture to the crank pin journals.
- (8) Install each connecting rod end cap (with the bearings installed) on their respective crank pins on the crankshaft (where the numbers on the connecting rods and bearing locks point down - toward the oil sump.)

 **CAUTION** CORRECT INSTALLATION OF THE NEW NUT ON EACH NEW CONNECTING ROD BOLT IS NECESSARY FOR CORRECT CONNECTING ROD ASSEMBLY. EACH CONNECTING ROD NUT HAS TWO DIFFERENT SURFACES, ONE SURFACE IS FLAT AND THE OTHER HAS A RAISED LIP. BE SURE TO INSTALL EACH NUT ON THE CONNECTING ROD BOLT WITH THE FLAT FACE TOUCHING THE ROD. THE RAISED LIP SURFACE IS AWAY FROM THE ROD. THE CONNECTING ROD BOLT CANNOT BE TIGHTENED CORRECTLY IF THE NUT ON THE CONNECTING ROD IS INSTALLED INCORRECTLY.

- (9) Install a new nut on each new connecting rod bolt where the flat face of the nut touches the connecting rod as shown in Figure 53.
- (10) Torque the connecting rod bolts per the torque values in the latest revision of Service Instruction No. SI-1458. (Stretch bolts require an initial torque and are then torqued to the correct stretched length.)
- (11) Measure the side clearance between the connecting rod and crankshaft with a feeler gage where shown in Figure 54. The clearance is to be 0.004 to 0.016 in (0.102 to 0.406 mm).

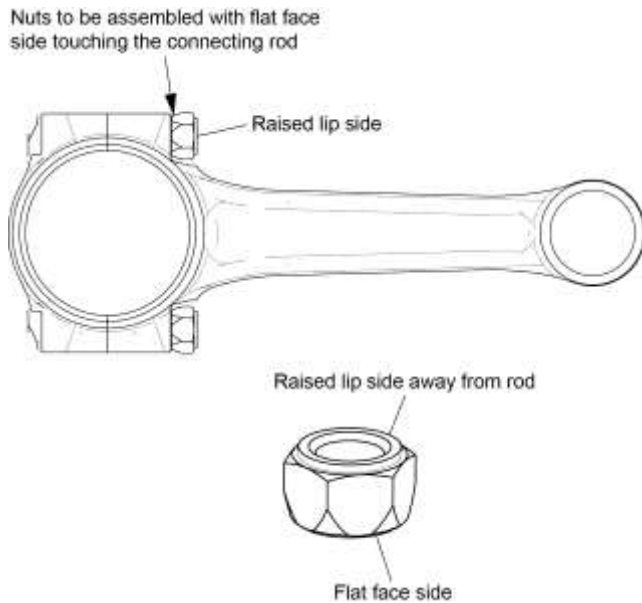


Figure 53
Connecting Rod Nut Installation

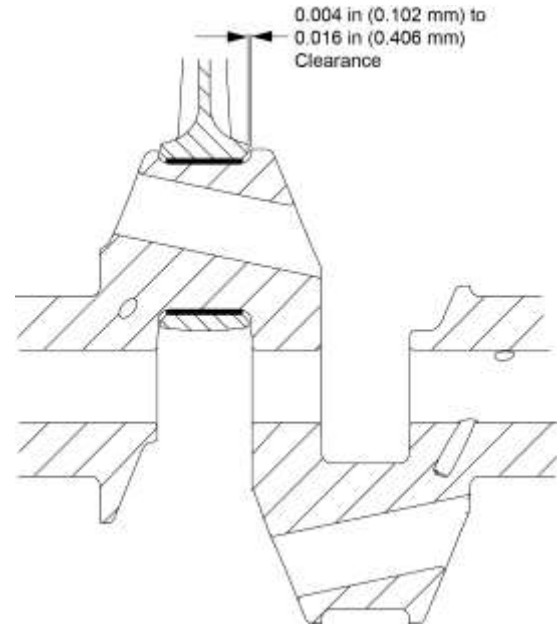


Figure 54
Connecting Rod Clearance

F. Counterweight Installation

⚠ CAUTION DURING INSTALLATION, DO NOT MAKE SCORES, SCRATCHES, OR ETCH MARKINGS OF ANY KIND ON THE CRANKSHAFT, COUNTERWEIGHTS AND ROLLERS. A MARK IN ANY OF THESE AREAS CAN CAUSE THE PART TO WEAKEN AND TO FAIL.

NOTICE: Refer to the *TEO-540-A1A Illustrated Parts Catalog* for counterweight bushing part numbers.

- (1) Install new counterweight bushings per instructions in the latest revision of Service Instruction No. 1143.
- (2) Make sure the counterweights of the correct order and part number are to be installed on the crankshaft. Refer to the latest revision of Service Instruction No. SI-1012.

⚠ CAUTION DO NOT INSTALL TWO DIFFERENT ROLLERS ON THE SAME COUNTERWEIGHT. ALL MUST BE MATCHED PAIRS OF IDENTICAL PARTS.

- (3) Measure the outside diameter of each roller to be installed to make sure it is in compliance with the dimensions in the latest revision of Service Instruction No. SI-1535.
- (4) Install the applicable counterweight on the correct crankshaft lobe and configuration as identified in the applicable parts catalog.
- (5) Install the roller pair in the counterweight.

NOTICE: A new circlip pair and a new pair of washers must be installed on each counterweight during assembly. Refer to the latest revision of Service Instruction No. SI-1535 to identify the correct P/N for the new circlips.

- (6) Install a new counterweight washer in each of the two holes on the counterweight as shown in Figure 55.
- (7) Install a new circlip on one side of each counterweight with the sharp edge outward as shown in Figure 55.

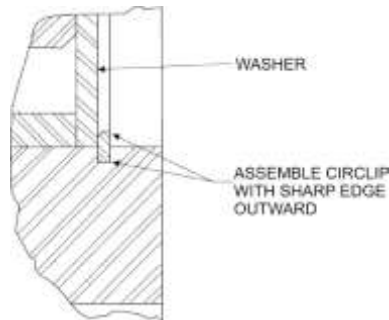


Figure 55
Assembly of Circlips in Counterweight

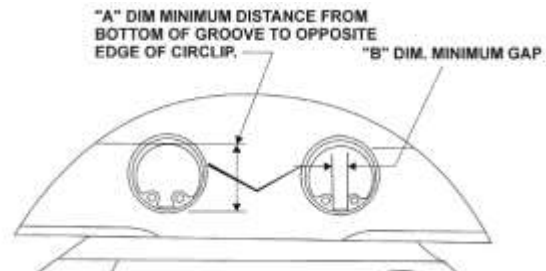


Figure 56
A and B Dimensions

- (8) Use the specified Lycoming gage set identified in the latest revision of Service Instruction No. SI-1535. Make sure the circlips are installed correctly on the counterweight (Figure 55). Figure 56 shows the location of the A and B dimensions. Dimension A is the diameter of the gage. Dimension B is the width of the gage.
- (9) Make sure the circlip seating is correct (Figure 58) as follows:
 - (a) Install one end of the counterweight Circlip Check Gage, P/N 64892-2 (Figure 57) between the ends of the circlip (Figure 59).

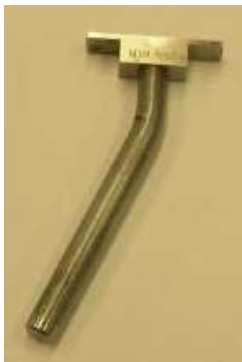


Figure 57
Circlip Check Gage P/N 64892-2



Figure 58
Circlip Installed



Figure 59
Insertion of Circlip Check Gage

- (b) Make sure the gage is on the bottom of the groove.
- (c) Pass the gage through the ends of the circlip.
- (d) Move the gage back and forth.
 - The gage must pass the ends of the circlip.
 - When moved back and forth, the gage must be clear of the inside edge of the top of the circlip.
- (10) If the gage does not move freely between the ends and under the top of the circlip, the circlip seating is not correct. Install the circlip again and complete a check of the circlip seating again per the previous steps. The circlip must be seated correctly.

17. Piston Cooling Nozzle Installation (if removed)

- A. Apply a coating of engine oil to all of the cleaned and inspected/acceptable piston cooling nozzles.
- B. Install three piston cooling nozzles in each crankcase half (Figure 60).
- C. Torque each piston cooling nozzle to 100 in.-lb. (11 Nm).

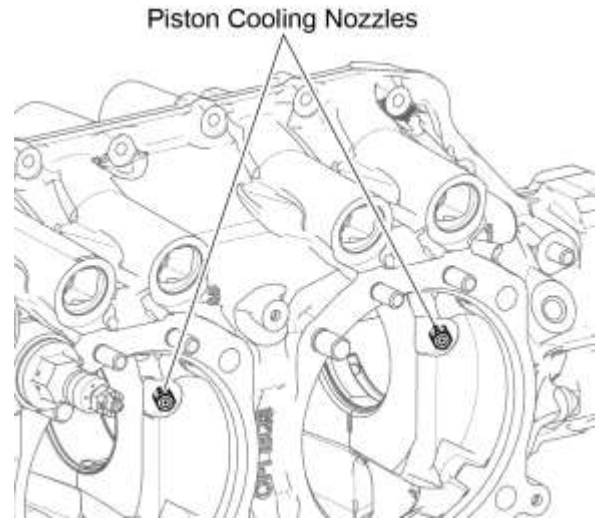


Figure 60
Piston Cooling Nozzles

18. Oil Plug Installation (if removed)

- A. Make sure the NPT oil plugs are acceptable, not damaged or cracked. Replace any worn, damaged or cracked oil plug.
- B. Apply a coating of Loctite[®] 564 or equivalent to all of the oil plugs.
- C. Install the NPT oil plugs in each crankcase half (Figures 15, 16, 17, and 61 A, B, and C).
- D. Torque each NPT oil plug in accordance with the latest revision of the *Service Table of Limits - SSP-1776*.



Figure A



Figure B



Figure C

Figures 61 A, B and C
Oil Plug Installation

19. Tappet Assembly Installation

NOTICE: Roller tappets (Figures 62 and 63) are installed in the crankcase halves on Lycoming TEO-540-A1A Engines.

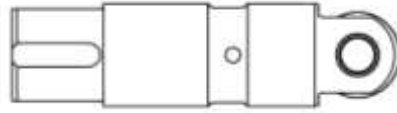


Figure 62
Roller Tappet



Figure 63
Installed Roller Tappets

A. Plunger Assembly Installation

CAUTION DO NOT MIX HYDRAULIC TAPPET PLUNGER OR LIFTER ASSEMBLIES WITH DIFFERENT PART NUMBERS IN THE SAME ENGINE. THE DIFFERENT LEAK DOWN RATES WILL CAUSE INCORRECT ENGINE OPERATION.

ALL PARTS OF EACH HYDRAULIC PLUNGER ASSEMBLY ARE SELECTIVELY FITTED AND ARE NOT INTERCHANGEABLE. MATING PARTS MUST BE KEPT TOGETHER. IF THERE IS ANY DOUBT AS TO WHETHER THE PARTS HAVE BECOME MIXED, INSTALL NEW PLUNGER ASSEMBLIES.

NOTICE Hydraulic tappet plungers are to be replaced if damaged, or not operating correctly, and at overhaul.

- (1) Clean and lightly coat the lifter parts with engine oil before assembly.
- (2) To assemble the unit, unseat the ball (Figure 64) by inserting a thin clean bronze wire through the oil inlet hole.
- (3) With the ball off its seat, insert the hydraulic tappet plunger and turn it clockwise until the spring engages.

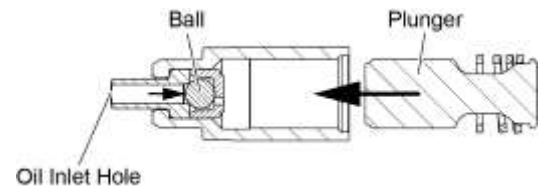


Figure 64
Hydraulic Lifter

B. Tappet Installation

NOTICE Roller tappets are not field repairable and are not to be disassembled for parts reuse.

Replace a roller tappet if it is damaged or not operating correctly with a serviceable tappet. Replace **all** of the roller tappets as a complete set with a new set of roller tappets under any of the following circumstances:

- During overhaul
- If the engine operation time is close to TBO
- During engine disassembly after a propeller strike or sudden engine stoppage

Refer to the latest revisions of Service Instruction Nos. SI-1011 and SI-1514.

- (1) Before installation, apply lubrication to the roller tappets per the latest revision of Service Instruction Nos. SI-1011 and SI-1059.

CAUTION TO PREVENT CAMSHAFT DAMAGE, BE SURE THE ROLLER SHAFT IN THE ROLLER TAPPET IS PARALLEL TO THE CAMSHAFT.

- (2) Install six serviceable roller tappets in each crankcase half during assembly.
- (3) Lubricate the camshaft lobes and the faces of the roller tappets (Figure 67) per the latest revision of Service Instruction No. SI-1059.

20. Crankshaft Bearing and O-Ring Installation

NOTICE: If O-ring holes have a countersink, apply Lubriko® M-6 Grease to the countersink before installing the O-rings.

The crankshaft front main bearings are installed on the crankshaft, not in the crankcase halves

- A. Install crankshaft bearings Nos. 2, 3, and 4 in the crankcase halves. Make sure the tangs are seated in the lock slots (Figures 65 and 66).

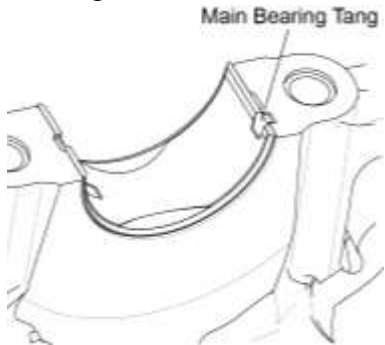


Figure 65
Main Bearing Tang

- B. Apply engine oil to two new O-rings.
- C. Install the two new O-rings (Figure 66).

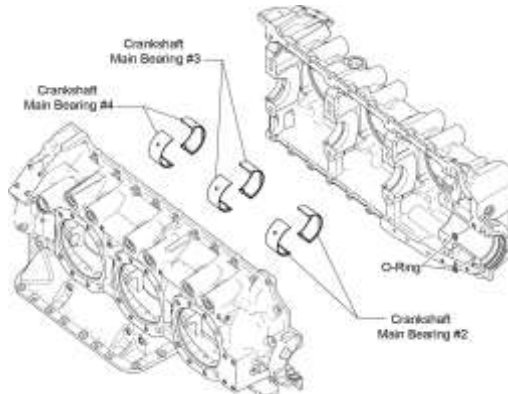


Figure 66
Crankshaft Bearings and O-Rings

21. Propeller Governor Drive Installation

NOTICE: Examine each component to be installed on the propeller governor drive. Replace any damaged or worn part with a new part. The gear assembly is installed in the left crankcase half before crankcase assembly.

The following **new** parts must be available to install the propeller governor drive:

- Four lock washers
 - Governor gasket
 - Governor drive cover gasket
 - Gear Assembly
 - Set screw
 - Thrust washer
- (different thickness sizes available - Table 2 - requires measurement of clearance in subsequent steps to identify the correct thrust washer)

Table 2
Thrust Washer Thickness

Thrust Washer Part Number	Thrust Washer Thickness	
	in.	mm
73249	0.0585 to 0.0595	1.4859 to 1.5113
73250	0.062 to 0.063	1.575 to 1.600
73251	0.0655 to 0.0665	1.6637 to 1.6891
73252	0.069 to 0.070	1.753 to 1.778
01L21418	0.055 to 0.056	1.397 to 1.422

A. Governor Drive Gear Installation

- (1) Lubricate the shaft of the propeller governor drive gear with engine oil and install the propeller governor drive gear in the left half of the crankcase.
- (2) Apply Lubriko[®] M-6 Grease or equivalent to the rear face of the propeller governor idler gear shaft.

NOTICE: In the next step, install the thickest thrust washer (Table 2) to keep the backlash at a low limit

- (3) Install the gear assembly and the thrust washer, as required to keep the backlash at a low limit, into the crankcase (Figure 67).
- (4) Install the propeller governor idler gear shaft into the crankcase through the gear assembly and thrust washer (Figure 68).

B. Backlash Check:

NOTICE: Refer to Section IV in the latest revision of the *Service Table of Limits - SSP-1776* for low limit and high limit propeller governor idler gear backlash.

- (1) To complete a check of the low limit backlash, insert a 0.008 inch shim between the spacer and crankcase (Figure 69).
- (2) Turn the propeller governor idler gear 90°. Record backlash. Remove and insert the shim at 90° intervals. Record the reading of each backlash check.
- (3) During assembly, to complete a check of the high limit backlash, try to insert a 0.021 shim between the spacer and crankcase. For correct backlash, the shim must not be insertable.

C. Propeller Governor Set Screw

NOTICE: To ensure that there is adequate material in the set screw hole topeen on top of the screw, use a new set screw that is shorter than the one previously removed. A smaller diameter center punch could be necessary. Refer to Figure 71.

- (1) Wear impermeable gloves and apply a light coat of Loctite[®] 290[™] or equivalent to the new set screw. Wipe away any excess Loctite[®] 290[™] with a clean lint-free cloth.
- (2) Install the set screw into the crankcase (Figure 70). Align the idler gear shaft with the set screw to enable the set screw to lock into the indentation in the idler gear shaft to hold the idler gear shaft in place.
- (3) Torque the set screw 32 to 38 in.-lb. (3.6 to 4.3 Nm).



Figure 67
Propeller Governor Idler Gear Assembly and Thrust Washer



Figure 68
Propeller Governor Idler Gear Shaft



Figure 69
Shim Between Spacer and Crankcase – Backlash Check



Figure 70
Set Screw Location

- (4) Use a smaller center punch (peening tool) with a 3/32-inch (2.38 mm) diameter at an approximate 50°/60° angle topeen the threads of the hole at the top of the taper above the set screw to prevent the set screw (as shown in Figure 71) from backing out.

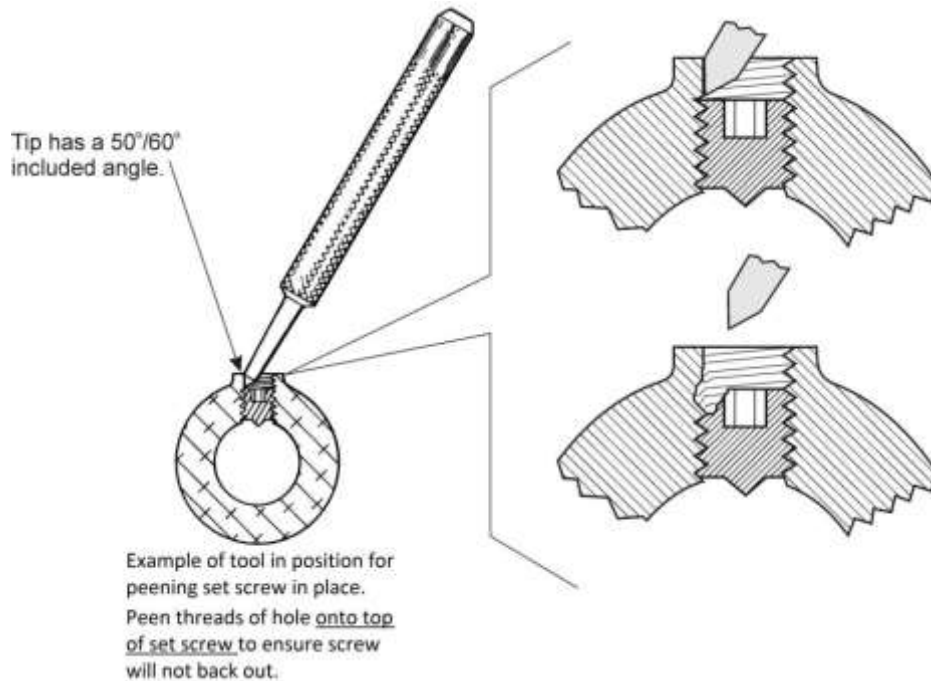


Figure 71
Center Punch (Peening Tool) for Set Screw

D. Idler Gear Shaft Plug Installation

- (1) Examine the idler gear shaft plug (Figure 72) to make sure it is not damaged or cracked. Replace a damaged or cracked idler gear shaft plug.
- (2) Lubricate the threads of the idler gear shaft plug with Anti-Seize.
- (3) Install the idler gear shaft plug into the crankcase with a new gasket.
- (4) Torque the idler gear shaft plug between 150 to 180 in.-lb. (17 to 20 Nm).
- (5) Safety wire/cable the idler gear shaft plug.



Figure 72
Idler Gear Shaft Plug

- E. Apply heavy lubricant such as Modoc or equivalent to the teeth on the idler gear and the propeller governor drive gear.

NOTICE: The governor drive cover or mask is to prevent FOD during engine assembly and will be removed when the propeller governor is installed.

- F. Install a governor drive cover or mask on the propeller governor mounting pad.
- G. Install four nuts on the studs in the crankcase to attach the governor drive cover or mask.

22. Camshaft Assembly and Installation

A. Camshaft Assembly

- (1) Install a new spacer and retaining ring (Figure 73) on the camshaft assembly.

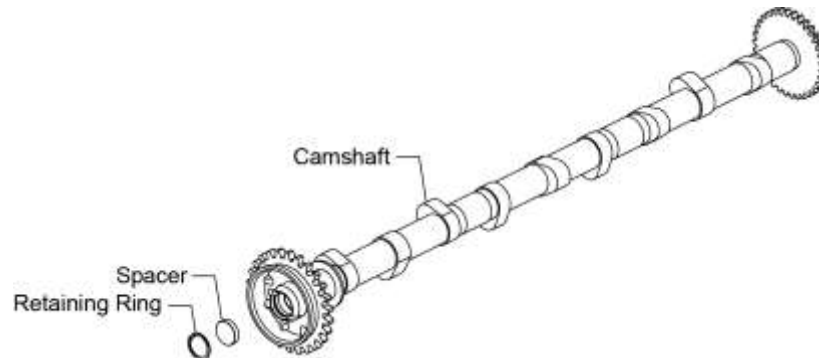


Figure 73
Camshaft Assembly

B. Camshaft Installation

NOTICE: Complete a camshaft end play clearance check in each crankcase half, remove the camshaft and install it in the other crankcase half to complete an end play clearance check. Refer to the “Camshaft Replacement Guidelines” section in the latest revision of Service Instruction No. SI-1011 for guidelines on replacing the camshaft when new tappets are installed in the engine.

- (1) Put the camshaft in the left crankcase half.

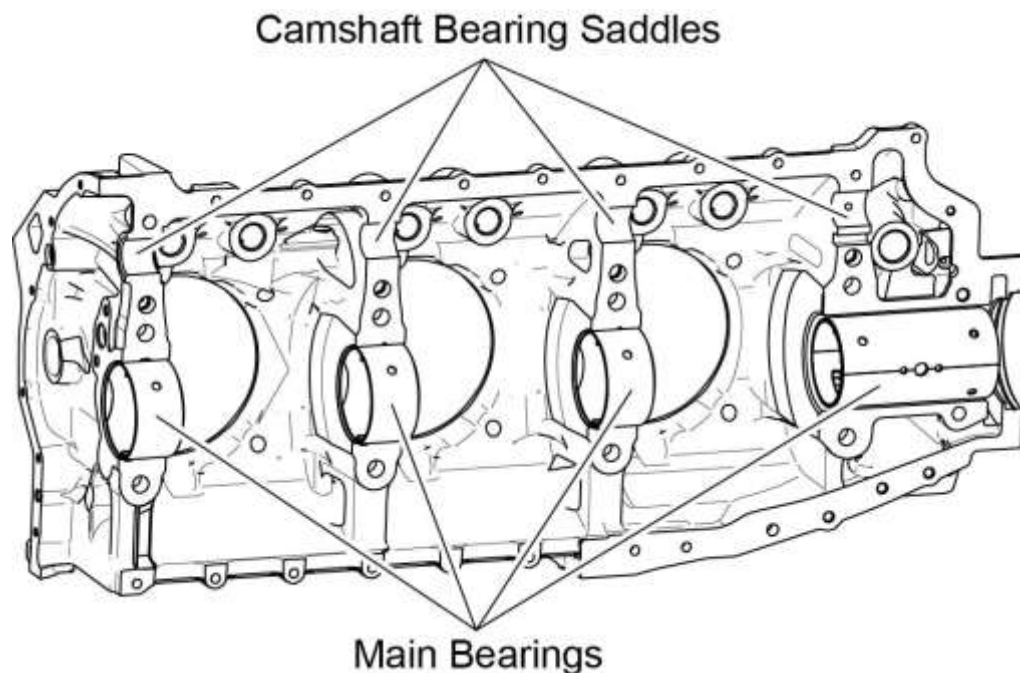


Figure 74
Main Bearing and Camshaft Bearing Saddles in Crankcase Half

- (2) Complete a check of the end play clearance of the camshaft using a feeler gage (Figure 75).
- (3) Remove the camshaft from the left crankcase half and install it in the right crankcase half and complete a check of the camshaft end play clearance.

Acceptable end play clearance.	0.002 to 0.015 in. (0.051 to 0.381 mm)
--------------------------------	---

NOTICE: If the end play clearance values are not within the allowable limits, examine the crankcase and/or camshaft for wear or damage. Replace a damaged or worn camshaft. If one crankcase half is worn or damaged, replace both crankcase halves as a matched set.



Figure 75
Camshaft End Play Clearance Check

- (4) Apply engine oil mixture (15% pre-lubricant (STP or equivalent) and 85% SAE No. 50 mineral base aviation grade lubricating oil) to the camshaft bearing saddles and main bearings on each crankcase half (Figure 76) and the camshaft lobes (Figure 77).
- (5) Refer to the latest revision of Service Instruction SI-1059 and apply the specified lubricant to the crankshaft thrust bearing surfaces of each crankcase half (Figure 76).



Figure 76
Thrust Bearing Surfaces of Each Crankcase Half



Camshaft



Roller Tappets

Figure 77
Lubrication to Roller Tappets and Camshaft Lobes

- (6) Install the camshaft in the left crankcase half.
- (7) Tie a loop of soft wire around the camshaft and left crankcase half (as shown in Figure 79) to hold the camshaft securely in place.



Figure 78
Lubricant Application to
Camshaft Bearing Saddle in Crankcase Half

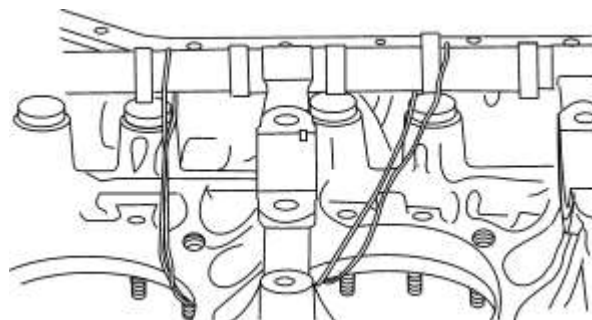


Figure 79
Example of Camshaft Wired to Crankcase Half

23. Crankshaft Installation

⚠ CAUTION BEFORE INSTALLATION, MAKE SURE THE CRANKSHAFT HAS SATISFACTORILY PASSED THE MAGNETIC PARTICLE INSPECTION AND DOES NOT HAVE ANY CRACKS. DO NOT INSTALL A CRANKSHAFT WITH A CRACK. ENGINE MALFUNCTION CAN OCCUR IF A CRANKSHAFT WITH A CRACK IS INSTALLED.

NOTICE: The connecting rods are to have been already installed on the crankshaft per the “Connecting Rod Installation” procedure in this chapter.

- A. Refer to the latest revision of Service Instruction No. SI-1059 and apply the specified lubricant to the main bearing journals of the crankshaft and the rear and center main bearing inserts in the right crankcase half.
- B. Install the Front Bearing Halves on the Crankshaft
 - (1) Apply a coating of engine oil mixture to the front bearing halves (Figure 13).
 - (2) Install the front bearing halves, where they touch (butt together) around the crankshaft.
 - (3) Lift the crankshaft assembly by the connecting rods. Lower the crankshaft assembly into the crankcase half (Figure 80). Let the connecting rods extend through the cylinder base openings in the crankcase half.

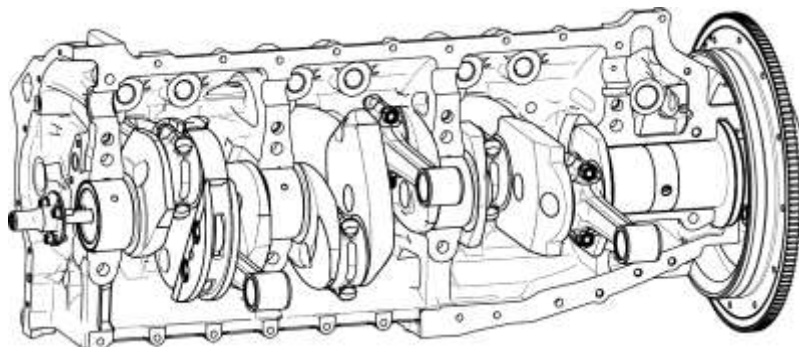


Figure 80
Crankshaft Installed in Crankcase Half

- (4) With the crankshaft assembly in the crankcase, align the dowel holes in the front bearing halves with the dowels in the crankcase.
 - (5) Make sure the two new front main bearings (Figure 13) are seated squarely over the locating dowels on the crankcase.
- C. Measure the Thrust Face Clearances Between the Crankshaft and Crankcase
- (1) With the crankshaft installed in the crankcase, move the crankshaft as far forward as possible.
 - (2) Use a feeler gage to measure the slinger clearance at Point A (Figure 81). Refer to the limits in Table 3. If the slinger clearance is not within the limits in Table 3, the front face of the slinger can be reground to restore the slinger clearance to within allowable limits.
 - (3) Move the crankshaft to the rear as far as possible.
 - (4) Use a feeler gage to measure the end play clearance with the crankcase thrust at Point B in Figure 81. Refer to the limits in Table 4. If the end play clearance is not within the limits in Table 4, examine the crankcase and/or crankshaft for wear or damage. Replace a worn or damaged component.

Table 3
Slinger Clearance at Point A
(Figure 81)

Inches	Millimeters
0.002 to 0.007	0.051 to 0.178

Table 4
End Play Clearance at Point B
(Figure 81)

Inches	Millimeters
0.009 to 0.026	0.229 to 0.660

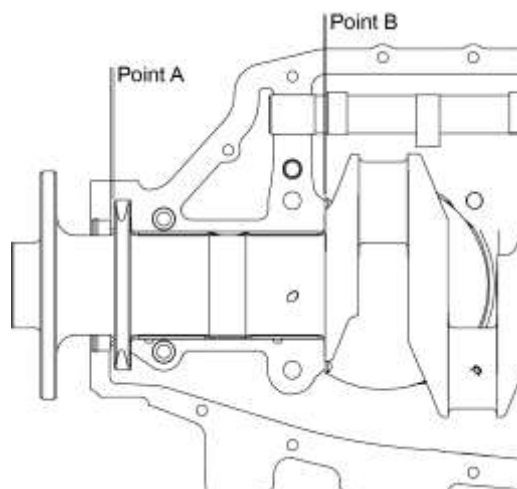


Figure 81
Clearance Between Crankshaft and Crankcase

24. Crankcase Assembly

NOTICE: Before assembly, make sure the crankcase has been cleaned per the “Crankcase Cleaning” procedure in Chapter 05-30 in this manual. If a crankcase stud is bent, broken, damaged, loose, rusted, corroded, or cannot be cleaned, refer to the “Stud Replacement” procedure in Appendix A.

A. Assemble the Crankcase Halves

CAUTION THE CRANKCASE HALVES ARE A MATCHED SET, IF ONE HALF IS CRACKED OR DAMAGED BOTH HALVES MUST BE REPLACED. ONLY LYCOMING-APPROVED SEALANTS ARE TO BE USED DURING CRANKCASE ASSEMBLY. DO NOT USE ANY OTHER NON-APPROVED SEALANT SINCE IT COULD CAUSE A LOSS OF CLAMPING FORCE AND/OR TORQUE.

⚠ CAUTION IN THE NEXT STEP, DO NOT GET THE GASKET COMPOUND IN THE BORE OF THE NOSE SEAL OR IN ANY CRANKCASE BORE. IF NON-HARDENING GASKET COMPOUND GETS INTO THE NOSE SEAL BORE OR ANY CRANKCASE BORE, CAREFULLY REMOVE THE GASKET COMPOUND WITH A SOFT CLOTH AND SOLVENT (ACETONE, MEK, OR EQUIVALENT). DO NOT GET MEK ON THE CRANKSHAFT OIL SEAL.

- (1) Apply a thin layer of non-hardening gasket material such as POB #4 Perfect Seal gasket compound or equivalent to the outside mating surfaces of each crankcase half (darker area shown in Figure 82.)
- (2) Measure and cut a total of four continuous lengths of "00" silk threads (four for only one crankcase half). Two of the lengths will extend along the entire length of the top of the crankcase flange as shown in Figure 82, and two silk thread lengths will be shorter to cover the distance shown on the bottom flange of the same crankcase half. Do not apply silk thread pairs to both crankcase halves.

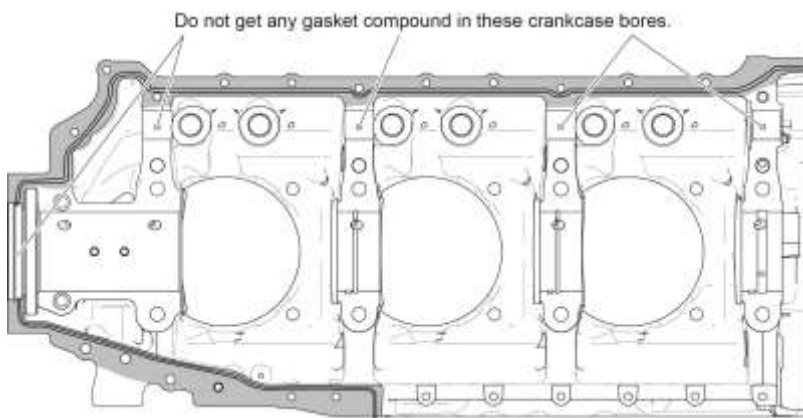


Figure 82
Area on the Crankcase Flange to Apply the POB Sealant and Silk Thread



Figure 83
Placement of Silk Threads Along Inside Edge of Crankcase Flange

⚠ CAUTION TO ENSURE CORRECT SEALING, MAKE SURE THE SILK THREADS RUN THE LENGTH, EACH THREAD AS A CONTINUOUS PIECE, OF THE INSIDE OF THE CRANKCASE FLANGE (FIGURE 82) AND THERE ARE NO BREAKS IN ANY OF THE THREADS. BREAKS IN THE SILK THREAD CAN CAUSE THE CRANKCASE TO LEAK.

- (3) Press two lengths of "00" silk threads in the gasket compound on the top and bottom flange sides (of the crankcase half) (Figure 82) firmly in the gasket compound where both silk threads are oriented in the area between the bolt holes and the inside flange edge of the crankcase half (approximately between 0.020 to 0.040 in. (0.508 to 1.106 mm)) apart as shown in Figure 83. Make sure that the silk thread lengths do not touch or cross over one another or cover a bolt hole.

- (4) All continuous silk thread lengths must extend not more than ¼-in. (6.35 mm) beyond the front and rear end of the crankcase half. Figure 84 shows the correct thread overhang extension into the seal groove on the front end of the crankcase half. Figure 85 shows the silk thread overhang extending from the rear of the crankcase half.


Figure 84
Silk Thread Extending into Seal Groove on the Front End of the Crankcase

Figure 85
Silk Thread Extending into the Rear End of the Crankcase

- (5) Wipe all excess sealant from the inner edges of the crankcase.

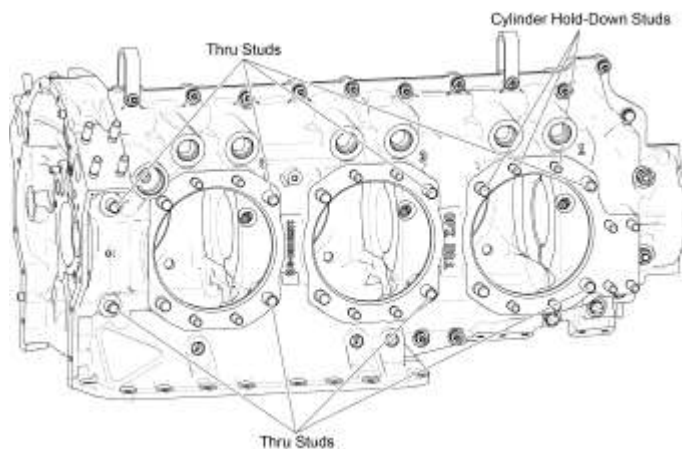
NOTICE: If a solid-ring crankshaft oil seal was installed on the crankshaft, make sure it is positioned toward the crankshaft flange and does not touch either crankcase half when the crankcase is assembled.

- (6) Lift the right half of the crankcase while keeping the halves parallel, lower the right half of the crankcase over and onto the left crankcase half for the studs to align.
- (7) When the crankcase halves are aligned correctly, tap the right half of the crankcase with a rubber mallet to make sure the crankcase halves are aligned and mated firmly all around and that there are no gaps between the mating flange surfaces. Do not continue if the crankcase halves are not aligned. Repeat the previous steps until the crankcase halves align.
- (8) Apply a coat of #2 Permatex[®] to the thru-studs at the dowel section.

⚠ CAUTION BE SURE TO LUBRICATE THE CRANKCASE THRU-STUDS TO ENSURE CORRECT FASTENING OF THE CRANKCASE HALVES.

- (9) Install thru-studs on the crankcase in the specified locations in Figure 86 where the studs extend equally on both sides of the crankcase. (An optional Crankcase Thru-Stud Driver ST-317 can be used to install thru-studs.)

- (10) Lubricate the threads of each crankcase thru-stud with the specified lubricant identified in the latest revision of Service Instruction No. SI-1029.


Figure 86
Right Side of Crankcase Showing Thru-Studs Installed

- (11) Install the Torque Hold-Down Plate (ST-222, Figure 87) on the cylinder pads over the thru-studs.

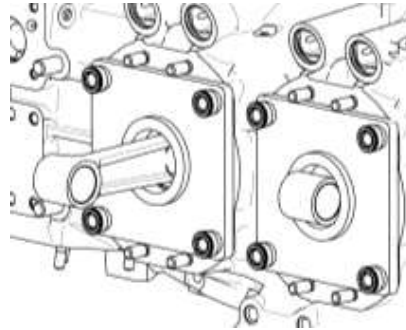


Figure 87
Torque Hold-Down Plates (ST-222)

- (12) Attach the plates with washers and nuts on the thru-studs. Tighten the nuts only finger tight at this time.
- (13) Make sure that the plates remain parallel with the cylinder decks of the crankcase.

NOTICE: Before tightening the thru-studs, make sure that they extend equally on both sides of the crankcase.

CAUTION TO ENSURE CORRECT ASSEMBLY OF THE CRANKCASE HALVES, TO MINIMIZE THE POSSIBILITY OF THE SUBSEQUENT LOOSENING OF CYLINDER BASE NUTS, AND TO ENSURE A UNIFORM LOAD ON THE MAIN BEARINGS IN THE CRANKCASE, FOLLOW THE STEPS IN THE TORQUE SEQUENCE IN THE ORDER GIVEN IN FIGURE 88.

- (14) Install a nut (and spacer as required) on each thru-stud at the mating flanges on the crankcase halves in the sequence shown in Figure 88 to attach the crankcase halves securely.

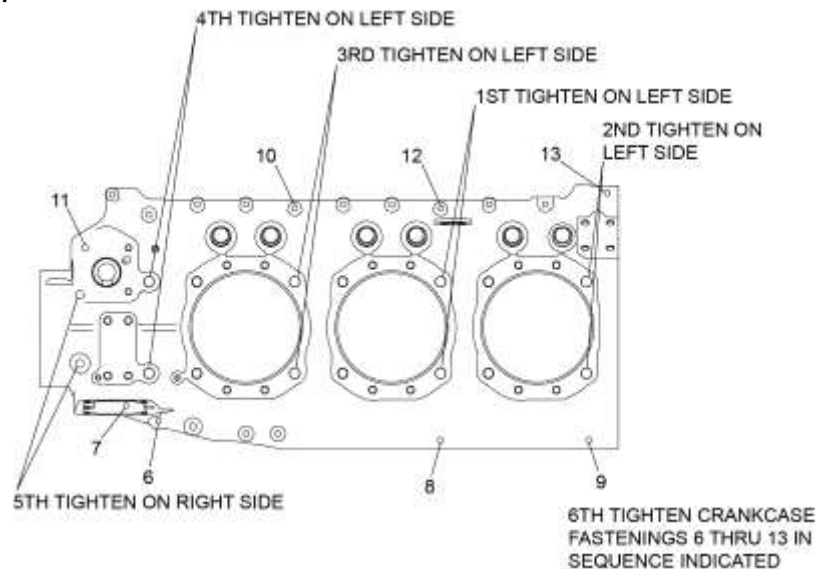


Figure 88
Crankcase Tightening Sequence

NOTICE: To ensure uniform loading on the main bearings, immediately torque the nuts on the thru-studs in sequence (Figure 88), beginning at the center of the crankcase and then progressing alternately to the rear and front of the engine.

- (15) Tighten the nuts on thru-studs at the:
 - (a) Rear of Cylinder 4 (tighten both sides at the same time).
 - (b) Rear of Cylinder 6 (tighten both sides at the same time).
 - (c) Rear of Cylinder 2 (tighten both sides at the same time).
 - (d) Front of Cylinder 1 (tighten both sides at the same time).
- (16) Torque the nuts in sequence at positions 1st, 2nd, 3rd, and 4th to 25 ft.-lb. (34 Nm).
- (17) Re-torque the nuts in sequence at positions 1st, 2nd, 3rd, and 4th per the torque values in Table 5.
- (18) Torque the front bolts at position 5 on the right side to 25 ft.-lb. (34 Nm).
- (19) Torque the nuts at positions 6 thru 13 (in the order shown in Figure 88) as indicated in Table 5.
- (20) Torque the remaining crankcase fasteners per Table 5.
- (21) Make sure all fasteners on the crankcase are torqued correctly and none are loose.
- (22) Install the 3/8 in. slotted nut and washer on the stud at the rear camshaft bearing (Figure 88). Torque the nut to 215 in.-lb. (24 Nm). Safety wire the nut as shown in Figure 89.
- (23) Apply Loctite[®] 564 or equivalent to the threads of the bolt (Figure 90) to be installed behind the governor pad.
- (24) Install the bolt behind the governor pad. Torque the bolt per the torque values in Table 5.



Figure 89

Nut on Stud at Rear Camshaft Bearing



Figure 90

Bolt Behind Governor Pad

CAUTION: MAKE SURE ALL FASTENERS ON THE CRANKCASE ARE TORQUED CORRECTLY AND NONE ARE LOOSE.

Table 5
Crankcase Fastener Torque Values

Fastener	Torque	Fastener	Torque
1/2-in. Nuts, thru-studs	50 ft.-lb. (68 Nm)	5/16 in. Bolts	17 ft.-lb. (23 Nm)
7/16-in. Nuts	35 ft.-lb. (48 Nm)	1/4 in. Nuts	96 in.-lb. (11 Nm)
3/8-in. Nuts	25 ft.-lb. (34 Nm)	1/4 in. Shear Nuts	55 in.-lb. (6 Nm)

NOTICE: Any additional crankcase fasteners not specifically called out in this procedure can be tightened in any sequence using the torque values shown in Table 5.

- (25) Before the oil sump is installed, safety wire the nuts that will be inside the oil sump in accordance with standard practices (Figure 91).



Figure 91
Safety Wire on the Nuts in the Crankcase Oil Sump

25. Crankshaft End Play Clearance Check

Complete the crankshaft end play clearance check after the crankshaft is installed and the crankcase halves have been assembled. Verify the crankshaft end play clearance is within acceptable limits.

- A. Attach a dial indicator gage to the crankcase starter pad.
- B. Move the crankshaft to the rear of the engine as far as possible.
- C. Position the dial indicator gage on the face of the crankshaft flange (Figure 92) and set the gage to read "0."
- D. Slide the crankshaft forward as far as possible.
- E. Read the end play measurement indicated by the gage.
- F. Set the gage to read "0" with the crankshaft as far forward as possible.
- G. Move the crankshaft to the rear of the engine as far as possible.
- H. Read the end play measurement indicated by the gage.
- I. Both measurements must be the same and the reading must be 0.009 to 0.026 in. (0.229 to 0.660 mm).
- J. If the measurements are not the same or if the end play clearance is not within the limits, disassemble the crankcase and examine the crankcase and/or crankshaft for wear or damage. Replace a worn or damaged component.



Figure 92
Crankshaft End Play Check

26. Propeller Oil Control Leak Test

- A. The purpose of this leak test is to identify any leaks, blockages (tight clearance) or openings (excessive clearance) of the propeller governor oil passages.
- B. Complete this leak test (with the propeller installed on the engine) if any of the following conditions occur:
 - During engine assembly
 - Suspect damaged propeller governor
 - Sluggish propeller operation
 - Engine does not hold rpm during cruise, climb, or descent
 - Engine front main bearing has too much clearance
 - Engine goes into feather during landing rollout with a decreased throttle setting

(1) Remove the propeller governor from the engine per the “Electronic Propeller Governor Removal” procedure in this chapter.

NOTICE: In the following steps, to prevent an air leak, use a propeller governor gasket P/N 72053 with test plate P/N ST-483 (Figure 93). Refer to the latest revision of Service Instruction No. 1462 for any updates.

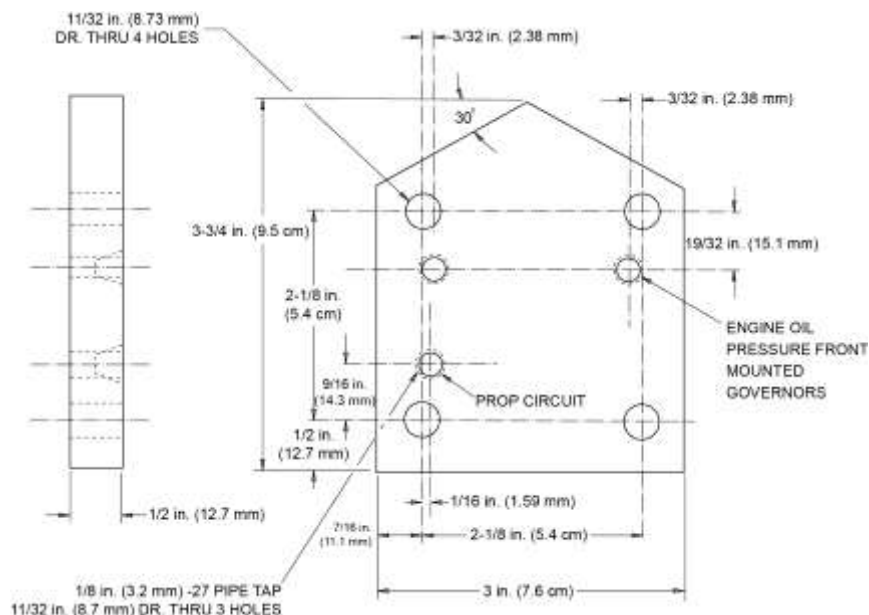


Figure 93
ST-483 Test Plate

- (2) Install the gasket and the test plate P/N ST-483, or equivalent on the governor pad with the air fitting in alignment with the governor oil passage that goes to the front bearing (forward hole) or left side of the mounting facing the pad. Refer to Figure 93.
- (3) Connect a calibrated oil pressure gauge (0 to 100 psi) (0 to 689 kPa) to the appropriate engine oil pressure port on the test plate for your governor location. Install a plug in the propeller circuit and unused engine oil pressure circuit port.

- (4) Start and warm-up the engine until the oil temperature is within the correct operating range (Appendix A of the *TEO-540-A1A Engine Installation and Operation Manual*.)

NOTICE: The oil pressure must not be more than 5 psi (34 kPa) below the lowest operating pressure of the operating range when the engine rpm is in the usual operating range.

- (5) With the engine OFF, remove the plug from the propeller circuit port and install a compression tester (Chapter 72-30) at the propeller circuit fitting on the test plate.

NOTICE: Allow 5 minutes after adjusting the first gauge to 40 psi (276 kPa), for air pressure to stabilize, before reading the pressure on the second gauge.

- (6) Apply shop air to the differential pressure regulator and adjust it to 40 psi (276 kPa) on the Gauge No. 1 (Figure 94. With the engine at operating temperature, the pressure reading on the Gauge No. 2 must read 6 to 35 psi (41 to 241 kPa), if the system is operating correctly.

NO. 1 GAUGE 40 psi (276 kPa)

NO. 2 GAUGE 6 psi to 35 psi (41 to 241 kPa) ACCEPTABLE

Above 35 psi (241 kPa)

Insufficient front main bearing clearance or a blockage in the propeller governor circuit

Below 6 psi (41 kPa)

Excessive front main bearing clearance

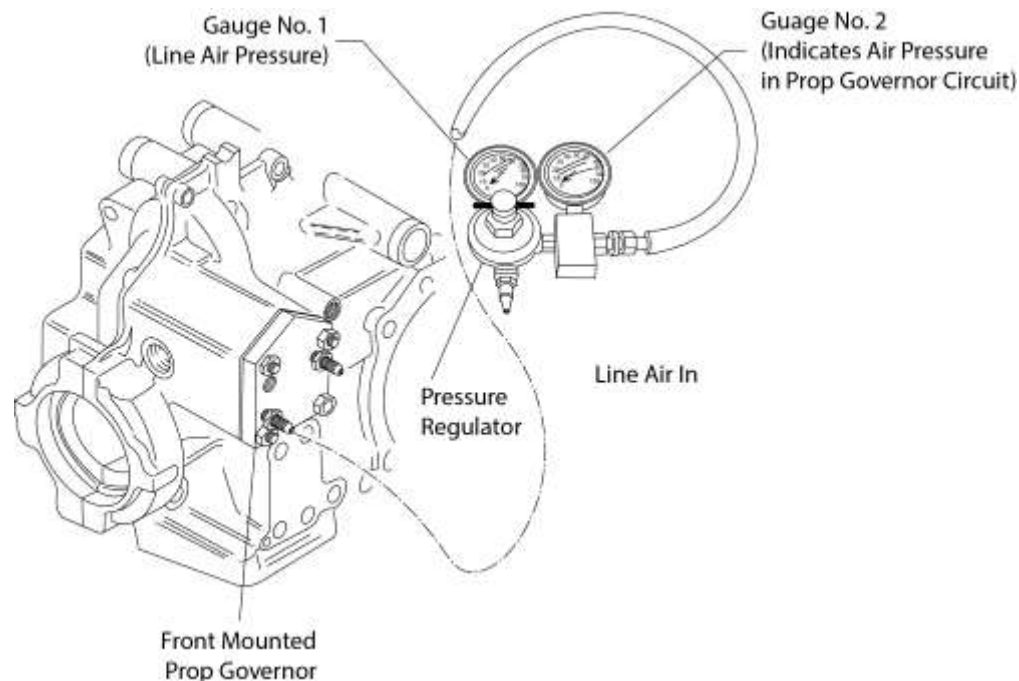


Figure 94
Propeller Governor Circuit Testing

- (7) Remove the test plate P/N ST-483 and gasket. Discard the gasket.
- (8) Install the propeller governor on the engine per the “Electronic Propeller Governor Installation” procedure in this chapter.

27. Crankshaft Oil Seal Installation

NOTICE: If a solid-ring crankshaft oil seal (Figure 45) is not already installed on the crankshaft a solid-ring crankshaft oil seal or split oil seal (Figure 44) can be installed after the crankcase is assembled.

A. Install the solid-ring crankshaft oil seal in the crankcase as follows:

- (1) Install a solid-ring crankshaft oil seal on the crankshaft per “Solid-Ring Crankshaft Oil Seal Installation“.
- (2) Use solvent and wipe excess grease from the crankshaft flange.

⚠ CAUTION DO NOT APPLY MEK SOLVENT TO THE CRANKSHAFT OIL SEAL SINCE MEK CAN CAUSE THE SEAL TO DETERIORATE. BE SURE THAT ALL TRACES OF CLEANING SOLVENT, OIL AND SEALANT ARE REMOVED PRIOR TO INSTALLATION OF A NEW CRANKSHAFT OIL SEAL.

- (3) Use ethyl alcohol and disposable wipes to clean the outer surface of the seal and the crankcase seal bore recess. Make sure nothing comes in contact with the cleaned surfaces.

⚠ CAUTION USE A BRUSH AND BUTYL RUBBER GLOVES WHEN APPLYING SEALANT AND INSTALLING THE OIL SEAL (FIGURES 95 TO 98).

NOTICE: In the next step, do not allow any sealant to contact the crankshaft or the seal lip (Figure 96). If any sealant gets on the crankshaft, use acetone to remove all traces of sealant.

If Pliobond® #20 or Pliobond® #25 is substituted for Dow Corning® 737 Neutral Cure Sealant, refer to the manufacturer’s instructions for application details and cure time.

- (4) Use a brush and wear butyl rubber gloves to apply a liberal coating of Dow Corning® 737 Neutral Cure Sealant to the outside diameter of the oil seal (Figure 95) to allow the excess sealant to squeeze out between the crankcase and the oil seal when the oil seal is installed.



Figure 95
Apply the Sealant to the Oil Seal



Figure 96
Apply the Sealant Only on
the Outer Surface of the Oil Seal

- (5) Work the sealant into the grooves of the solid-ring crankshaft oil seal (Figure 97).



Figure 97
Work the Sealant Into the Seal Grooves



Figure 98
Spread the Excess Sealant

- (6) Press the solid-ring crankshaft oil seal firmly and evenly against the seat in the crankcase bore. Apply pressure all around the seal until it is firmly seated in the bore.
- (7) Spread the excess sealant smoothly over the oil seal and crankcase (Figure 98)
- (8) Do not allow any sealant to contact the crankshaft or the seal lip. Wash the seal lip and crankshaft area with acetone and a cotton swab if contamination occurs. (Figure 96)
- (9) Let the Dow Corning® 737 Neutral Cure Sealant to cure for 24 hours.

NOTICE: Refer to the latest revision of Service Instruction No. SI-1324 for any additional details.

- B. Install a split oil seal (Figure 44) in the crankcase as follows:

- (1) Apply a thin film of Lubriko® M-6 Grease, or engine oil, or equivalent on the sealing surface of the seal and around the crankshaft at the sealing surface (Figure 99).



Figure 99
Apply Lubriko® M-6 Grease, Engine Oil or Equivalent to the Crankshaft

- (2) Clean the both ends of the split ring oil seal with ethyl alcohol.

NOTICE: The split oil seal has a finger spring bonded to the seal in the inner groove of the seal lip (Figure 100). Use care not to kink or distort the finger spring when installing the split oil seal on the crankshaft.

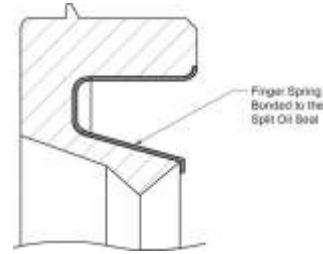


Figure 100
Finger Spring Bonded to the Split Oil Seal

- (3) Face the propeller end of the crankshaft and assemble the split oil seal around the crankshaft with the split at the 1:00 o'clock position (11:00 o'clock position for left-hand rotation engines) with the front face of the seal toward the crankshaft propeller flange.

NOTICE: If Pliobond® #20 or Pliobond® #25 is substituted for Dow Corning® 737 Neutral Cure Sealant, refer to the manufacturer's instructions for application details and cure time.

- (4) Apply a coat of Dow Corning® 737 Neutral Cure Sealant to one end of the split oil seal and press the ends of the seal together.

CAUTION DO NOT APPLY MEK SOLVENT TO THE SPLIT OIL SEAL SINCE MEK CAN CAUSE THE SEAL TO DETERIORATE. BE SURE THAT ALL TRACES OF CLEANING SOLVENT, OIL AND SEALANT ARE REMOVED PRIOR TO INSTALLATION OF A NEW SPLIT OIL SEAL.

- (5) Use ethyl alcohol and disposable wipes to clean the outer surface of the split oil seal and the crankcase seal bore recess. Make sure nothing comes in contact with the cleaned surfaces.

CAUTION USE A BRUSH AND BUTYL RUBBER GLOVES WHEN APPLYING SEALANT AND INSTALLING THE OIL SEAL (FIGURES 95 TO 98).

NOTICE: In the next step, do not allow any sealant to contact the crankshaft or the seal lip (Figure 96). If any sealant gets on the crankshaft, use acetone to remove all traces of sealant.

- (6) Use a brush and wear butyl rubber gloves to apply a liberal coating of Dow Corning® 737 Neutral Cure Sealant to the outside diameter of the oil seal (Figure 95) to allow the excess sealant to squeeze out between the crankcase and the oil seal when the oil seal is installed.

- (7) Work the sealant into the grooves of the split oil seal (Figure 97).

- (8) Press the split oil seal firmly and evenly against the seat in the crankcase bore. Apply pressure all around the seal until it is firmly seated in the bore.

- (9) Spread the excess sealant smoothly over the oil seal and crankcase (Figure 98)

- (10) Do not allow any sealant to contact the crankshaft or the seal lip. Wash the seal lip and crankshaft area with acetone and a cotton swab if contamination occurs. (Figure 96)

- (11) Let the Dow Corning® 737 Neutral Cure Sealant to cure for 24 hours.

NOTICE: Refer to the latest revision of Service Instruction No. SI-1324 for any additional details.

28. Crankshaft Trigger Gear Assembly and Crankshaft Idler Gear Installation

NOTICE: The left crankshaft idler gear, the camshaft gear, and the crankshaft trigger gear assembly all have etched circles, identified below and shown in Figure 101.

- Apply a liberal amount of engine oil to the idler gear shafts and crankcase shaft bore before assembly.
- The mark on one gear tooth of the left crankshaft idler gear (Figure 101) must mesh with the space between the marked teeth on the camshaft gear.
- The small etched circle on the crankshaft trigger gear assembly tooth must align with the involute between the two marked teeth of the left crankshaft idler gear. **No other combination of gear alignment will enable correct valve timing.**

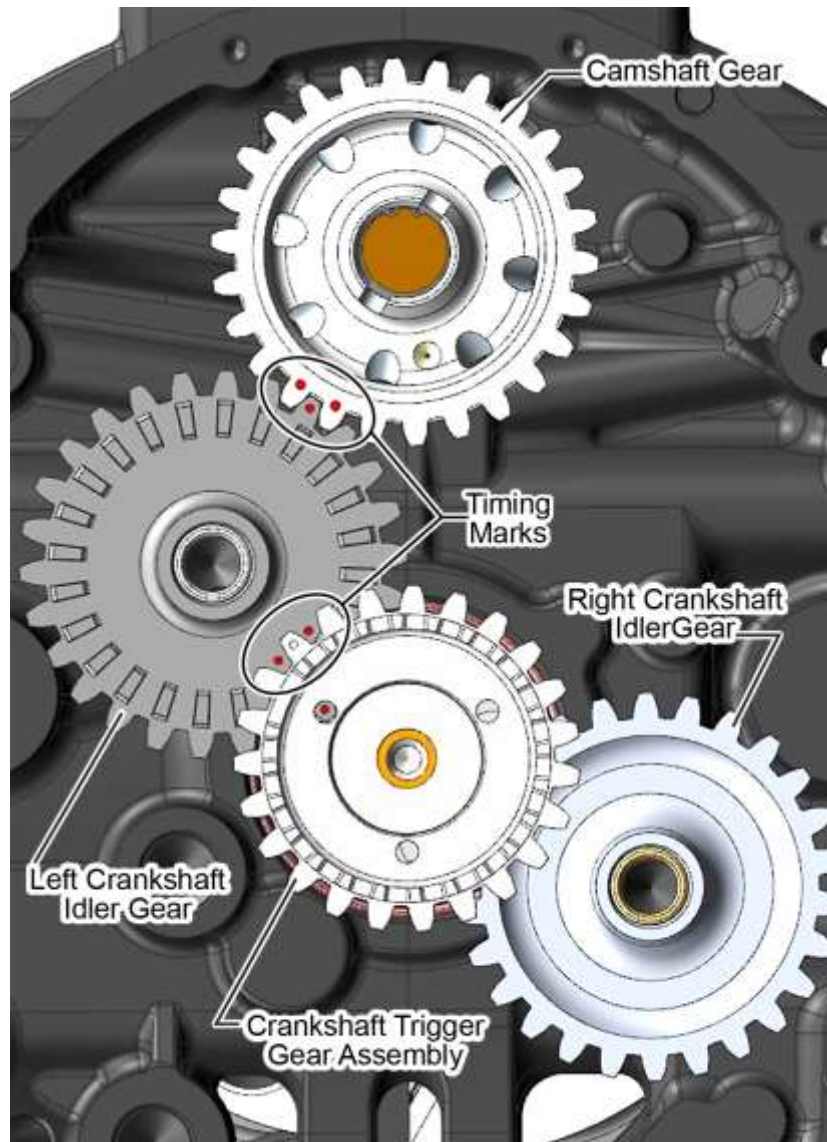


Figure 101
Timing Marks on the Right Crankshaft Idler Gear, Camshaft Gear,
and Crankshaft Trigger Gear Assembly

A. Turn the camshaft to position the timing marks as shown in Figure 101.

⚠ CAUTION DURING CRANKSHAFT ASSEMBLY, ALWAYS INSTALL A NEW CRANKSHAFT GEAR BOLT DO NOT REUSE THE CRANKSHAFT GEAR BOLT.

B. Apply a small amount of Loctite® Food-Grade Anti-Seize lubricant to the bottom three or four threads of the new crankshaft gear bolt. Wipe away any excess lubrication.

C. Assemble the left crankshaft idler gear, right crankshaft idler gear, and crankshaft trigger gear assembly with the timing marks on the crankshaft trigger gear assembly and left crankshaft idler gear aligned on the Idler Gear Assembly Aid (ST-532) and install the gears on the crankcase (Figure 102).

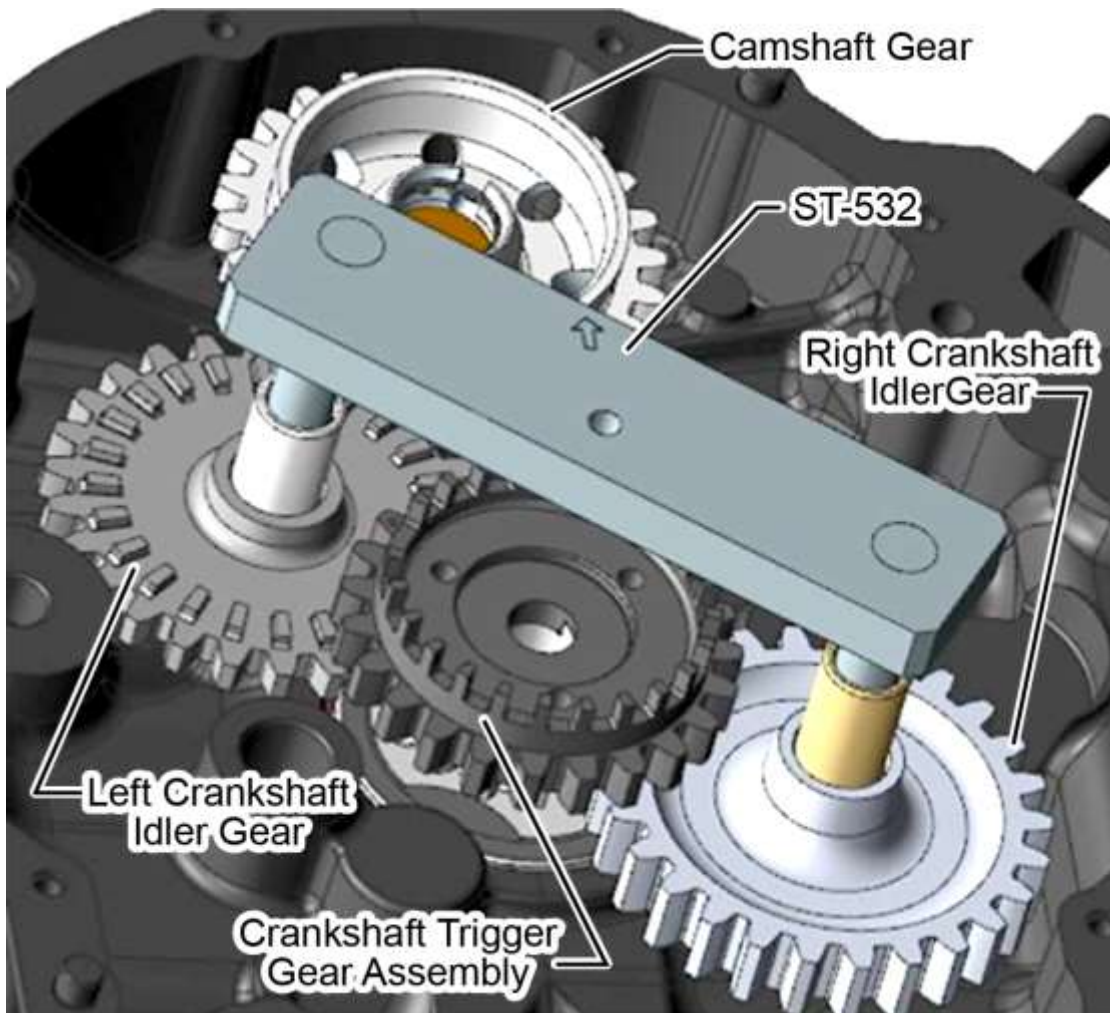


Figure 102

**Install the Left Crankshaft Idler Gear, Right Crankshaft Idler Gear,
and Crankshaft Trigger Gear Assembly**

D. Turn the crankshaft until the alignment dowel in the counterbored end aligns with the hole in the crankshaft trigger gear assembly pilot flange. Make sure the timing mark on the gear tooth of the left crankshaft idler gear (Figure 101) aligns with the space between the marked teeth on the camshaft gear.

- E. Remove the Idler Gear Assembly Aid (ST-532) and install the crankshaft gear bolt in the crankshaft (Figure 103).

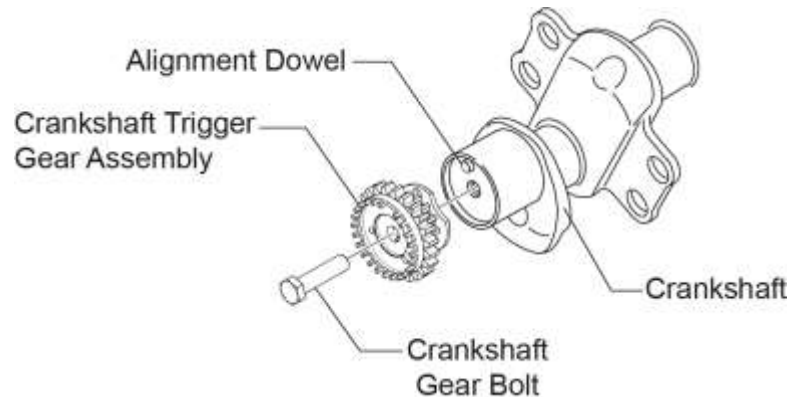


Figure 103
Crankshaft Gear Bolt

- F. Insert the Crankshaft Locking Tool (ST-534) through the connecting rod for cylinder number 4 and against the Torque Plate (ST-222) as shown in Figure 104. The Crankshaft Locking Tool prevents the crankshaft from turning while the crankshaft gear bolt is torqued.

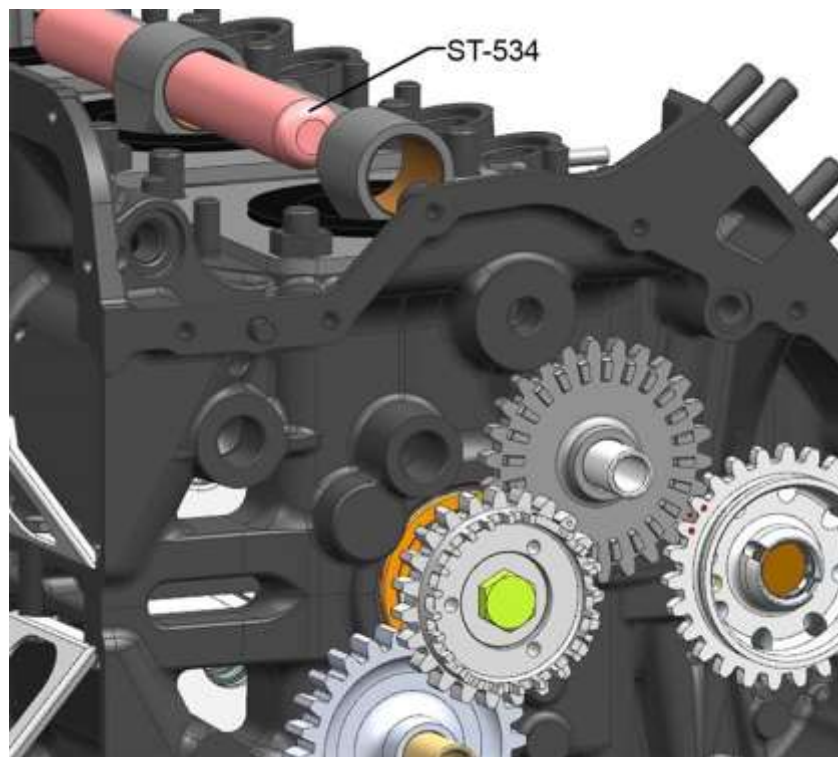


Figure 104
Insert Crankshaft Locking Tool (ST-534) Through the Connecting Rod

- G. Initially torque the crankshaft gear bolt (Figure 103) to 125 in.-lb. (14.12 Nm) torque.
- H. With a hammer and brass drift, tap lightly around the pilot flange of the crankshaft trigger gear assembly and listen for sharp solid sounds from the hammer blows that would indicate that the crankshaft trigger gear assembly is seated against the crankshaft.

- I. Make sure the crankshaft trigger gear assembly seats firmly and is perpendicular (not at a slanted angle) to the crankshaft as shown in Figure 105:

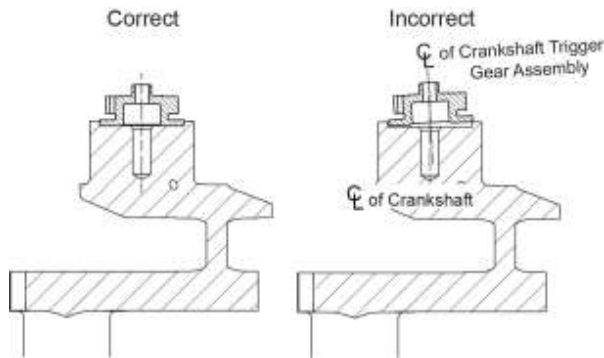


Figure 105
Crankshaft Trigger Gear Assembly Position



Figure 106
Crankshaft Trigger Gear Assembly Pilot Flange

- (1) Try to insert a pointed 0.001 in. (0.025 mm) feeler gage or shim between the pilot flange (Figure 106) of the crankshaft trigger gear assembly and crankshaft counterbore at each of the three scallops on the pilot flange of the crankshaft trigger gear assembly. The feeler gage must NOT fit between the two surfaces at any location. There must not be any gap or clearance between the crankshaft counterbored end and the pilot flange of the crankshaft trigger gear assembly.
 - (2) If clearance is found, remove the crankshaft gear bolt and crankshaft trigger gear assembly.
 - (3) Make sure the mating surfaces of the crankshaft trigger gear assembly and crankshaft counterbore are clean and dry and that there is no debris.
 - (4) Reinstall the crankshaft trigger gear assembly and crankshaft gear bolt. Repeat the initial torque and seating check above.
 - (5) Try again to put a pointed 0.001 in. feeler gage or shim stock between the crankshaft trigger gear assembly pilot flange and crankshaft counterbore at each of the three scallops on the crankshaft trigger gear assembly pilot flange.
- J. If there is no gap, the crankshaft trigger gear assembly is seated correctly. Complete the final torque of the crankshaft gear bolt to 204 in.-lb. (23.05 Nm).
- K. Install the fuel pump drive shaft (Figure 107) with three screws and three washers. Torque the screws to 100 in.-lb. (11 Nm).

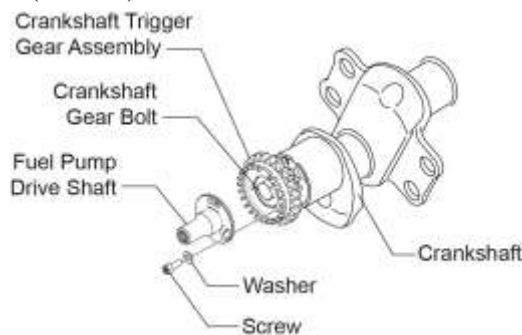


Figure 107
Fuel Pump Drive Shaft and Attaching Hardware

- L. Remove the Crankshaft Locking Tool (ST-534) from the cylinder #4 connecting rod.
- M. Install the Fuel Pump Drive Shaft Indicator Mount (ST-533) on the left crankcase locating dowel and adjacent tapped bolt hole (Figure 108).
- N. Check the fuel pump drive shaft run-out in two locations on the drive shaft. Run-out must be between 0.000 and 0.003 inch (0.076 mm). If the drive shaft run-out is greater than 0.003 inch (0.076 mm):
 - (1) Remove the drive shaft
 - (2) Turn the drive shaft 120°
 - (3) Re-install the drive shaft, screws, washers and torque to 100 in.-lb. (11 Nm).
 - (4) Re-check the drive shaft run-out.
- O. Safety wire the screws in the crankshaft trigger gear assembly as shown in Figure 109.

⚠ CAUTION

FAILURE TO LUBRICATE THE SHAFT OF THE HIGH-SPEED IDLER GEAR CAN CAUSE DAMAGE TO THE HIGH-SPEED IDLER GEAR UPON INITIAL ENGINE START.

- P. Apply a liberal amount of engine oil to the high-speed gear pilot and install the gear in the crankcase. Make sure the teeth of the high-speed idler gear engage correctly with crankshaft trigger gear assembly (Figure 110).

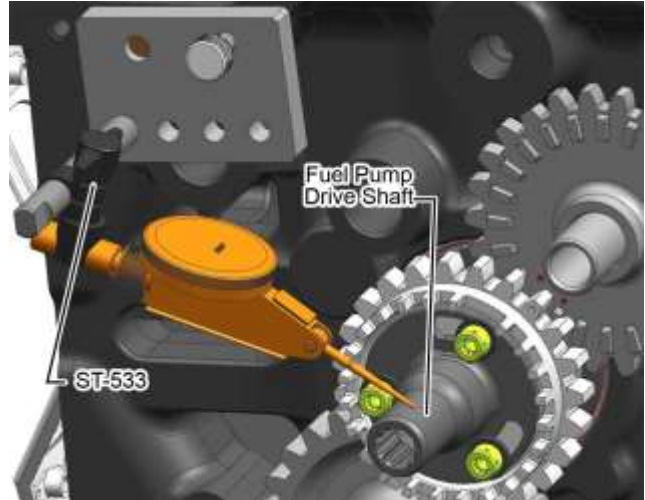


Figure 108
Fuel Pump Drive Shaft Indicator Mount (ST-533)

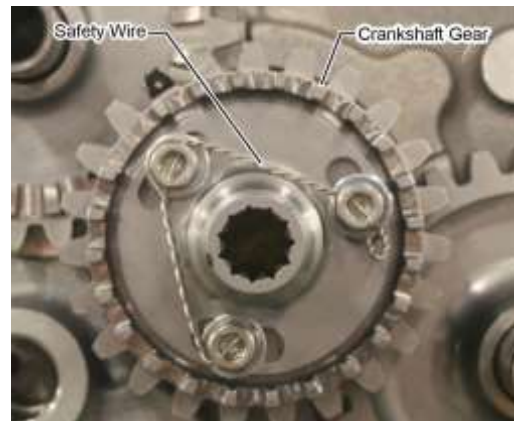


Figure 109
Safety Wire the Crankshaft Trigger Gear Assembly Screws

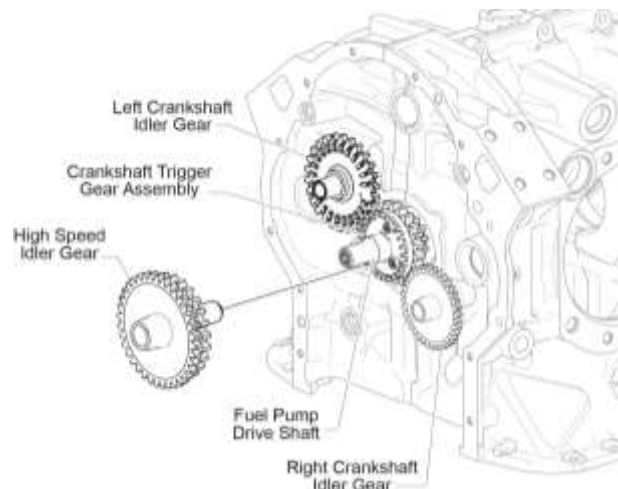


Figure 110
High Speed Idler Gear

29. Electronic Propeller Governor Removal

NOTICE: The electronic propeller governor is not field serviceable. Remove and send the electronic propeller governor to Lycoming Engines for repair or replacement.

- A. Disconnect the wiring harness from the electronic propeller governor per instructions in the “Wiring Harness Connector” section in Chapter 72-70.
- B. Remove the four nuts, lock washers, and washers (Figure 111) from the electronic propeller governor.
- C. Remove the electronic propeller governor and governor gasket from the crankcase. Discard the governor gasket.

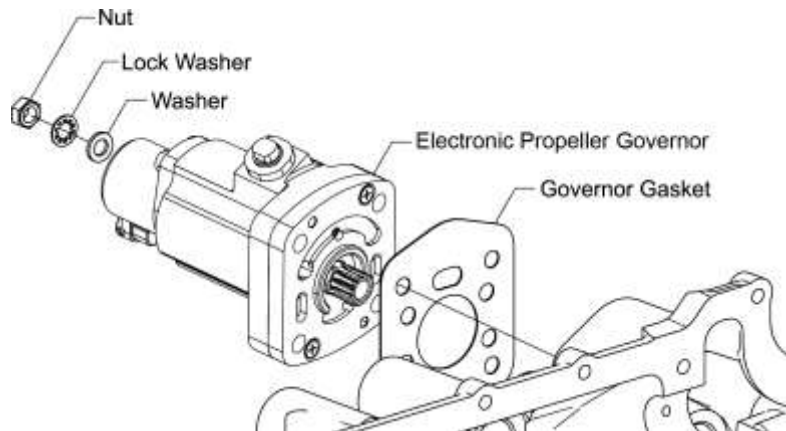


Figure 111
Electronic Propeller Governor

30. Electronic Propeller Governor Installation

- A. If a governor drive cover or mask is installed on the crankcase, remove the four nuts and the governor drive cover or mask.
- B. Coat the splines of the electronic prop governor drive shaft with Castrol® Moly Guard or equivalent.
- C. Install the electronic propeller governor (Figure 111) with a new governor gasket on the studs in the crankcase.
- D. Install the four washers, new lock washers, and nuts on the studs in the crankcase. Torque the nuts to 96 in.-lb. (11 Nm).
- E. Connect the wiring harness to the electronic propeller governor per instructions in the “Wiring Harness Connector” section in Chapter 72-70.

31. Crankshaft-to-Camshaft Timing Check

NOTICE: This timing check is completed on a partially or fully assembled engine without removing the accessory housing.

- A. Make sure the ignition and all electrical switches are OFF.
- B. Disconnect all spark plug leads.
- C. Disconnect the starter.

- D. Remove one spark plug from each cylinder per the “Spark Plug Removal” procedure in Chapter 74-20 in the *TEO-540-A1A Series Engine Service Manual*.
- E. Remove the rocker box cover on Cylinder 2 as per the “Exhaust Valve and Guide Inspection” procedure in Chapter 72-30 in the *TEO-540-A1A Series Engine Service Manual*.
- F. Rotate the crankshaft to position Cylinder 1 piston at Top Dead Center (TDC) on the compression stroke.
- G. Monitor the movement of the intake and exhaust valves in Cylinder 2 as you rotate the crankshaft to move the piston just past TDC of Cylinder 1.
- H. The crankshaft-to-camshaft timing is correct if the intake valve and the exhaust valve in Cylinder 2 just begins to close as the intake valve starts to open as the piston in Cylinder 1 goes over TDC on compression.
- I. If this simultaneous opening and closing of the intake and exhaust valves just past TDC does not occur, the crankshaft-to-camshaft timing is not correct. Repeat this timing check. If the results are the same, remove the accessory housing per Chapter 72-25 and complete a check of the alignment of the crankshaft idlers gears per the “Crankshaft Idler Gear Installation” section in this chapter.
- J. If the crankshaft-to-camshaft timing is correct:
 - (1) Install the rocker box cover on Cylinder 2 with a new rocker box cover gasket as per the “Cylinder Installation” procedure in Chapter 72-30.
 - (2) Install all top spark plugs, each with a new gasket, per the “Spark Plug Installation” procedure in Chapter 74-20.
 - (3) Reconnect the starter.
 - (4) Reconnect all spark plug leads

This page intentionally left blank.

72-25 - ACCESSORY HOUSING MAINTENANCE

1. Accessory Housing Removal

NOTICE: Before removing the accessory housing, turn the crankshaft to position the piston in Cylinder 1 at Top Dead Center (TDC).

- A. If not already done, drain the oil from the oil sump per the “Oil Change Procedure” in Chapter 12-10.
- B. Remove the fuel pump per the “Fuel Pump Removal” procedure in Chapter 73-10.
- C. Remove the oil filter per instructions in the “Oil Filter Replacement” procedure in Chapter 12-10.
- D. Disconnect the hoses to the airframe-supplied oil cooler.
- E. Remove the Permanent Magnet Alternator (PMA) per instructions in Chapter 72-70.
- F. Disconnect the hose to the turbo scavenge pump.
- G. Remove the turbo scavenge pump per instructions in this chapter.
- H. Remove any other accessories on the accessory housing per airframe manufacturer’s instructions.

NOTICE: There are two different size bolts used on the accessory housing. Identify and keep the bolts separate for correct reassembly.

- I. Remove the bolts, nuts, lock washers, and washers from the external side of the accessory housing (Figure 1) and the bolts, lock washers, and washers that attach the accessory housing to the oil sump. Discard the lock washers.

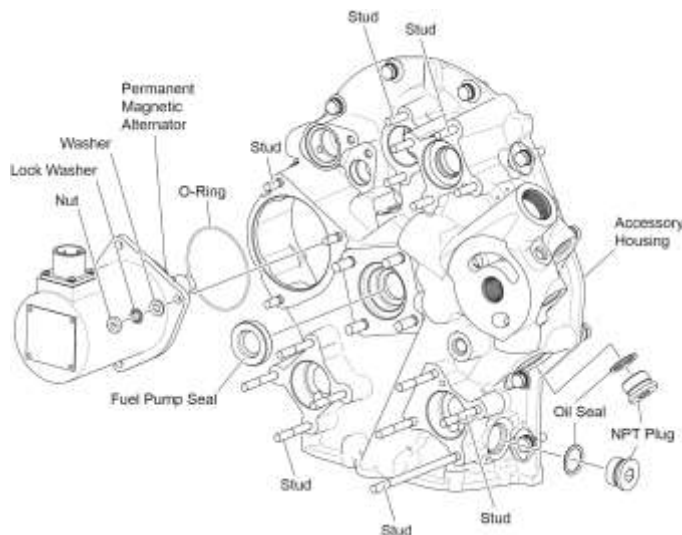


Figure 1
Hardware on External Side
of Accessory Housing

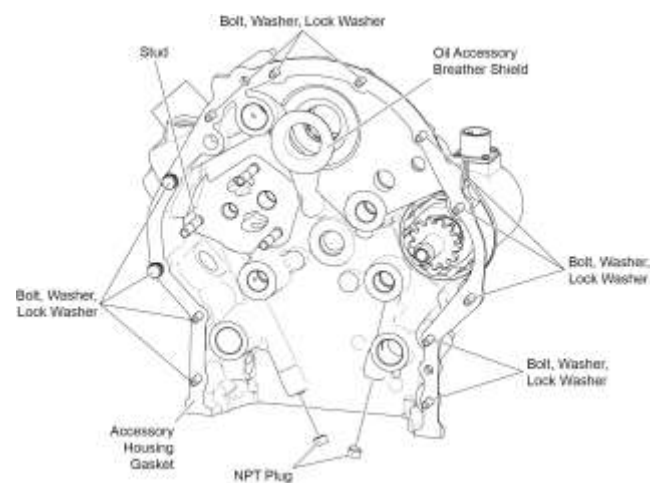


Figure 2
Accessory Housing

- J. Remove the accessory housing from the engine.
- K. Remove and discard the accessory housing gasket (Figure 2).

2. Oil Pump Removal

- A. Remove the safety wire (Figure 3) from the slotted nuts that attach the oil pump body assembly to the accessory housing.



Figure 3
Safety Wire on the Oil Pump

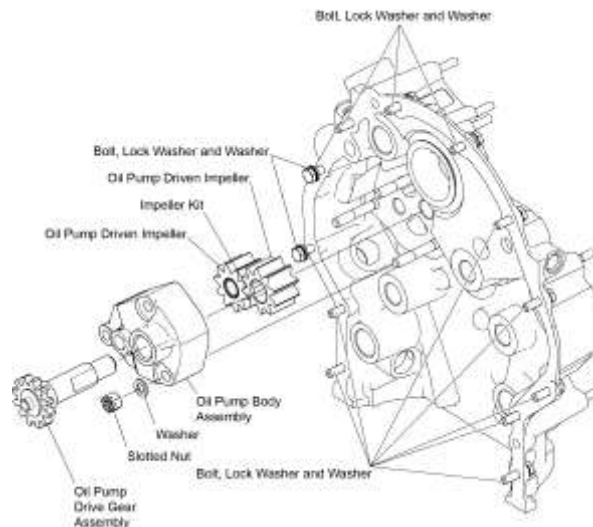


Figure 4
Oil Pump and Internal Side of the Accessory Housing

- B. Remove the three slotted nuts and three washers that attach the oil pump body assembly to the studs in the accessory housing.
 - C. Remove the oil pump drive gear assembly from the oil pump body assembly (Figure 4).
 - D. Remove the oil pump body from the accessory housing.
 - E. Remove the impellers from the oil pump body assembly.
- ## 3. Oil Pump Installation
- A. Lubricate all parts of the oil pump with a mixture of 15% pre-lubricant and 85% SAE No. 50 mineral base aviation grade lubricating oil.
 - B. Install the impellers in their respective compartments in the oil pump body assembly (Figure 4).
 - C. Install the oil pump body assembly over the mounting studs on the accessory housing.
 - D. Install the oil pump drive gear assembly into the oil pump body assembly and through impeller (Figure 4).
 - E. Install a washer and slotted nut on each of the three studs on the accessory housing.
 - F. Tighten the three slotted nuts gradually and evenly, turning the drive gear shaft while tightening to ensure free movement of the impellers.
- NOTICE:** If the oil pump drive gear assembly binds while tightening the slotted nuts, remove the oil pump, examine all parts of the oil pump for wear or damage. Replace worn or damaged parts as necessary and re-install the oil pump.
- G. Torque the slotted nuts to 17 ft.-lb. (23 Nm).
 - H. Safety wire the three slotted nuts as shown in Figure 3.

4. Turbo Scavenge Pump Removal

- A. Remove the four nuts, lock washers, and washers from the studs attaching the vacuum pump cover to the turbo scavenge pump (Figure 5). Discard the lock washers.
- B. Remove the vacuum pump cover and accessory adapter gasket from the turbo scavenge pump. Discard the gasket.
- C. Remove the four nuts, lock washers, and washers from the studs attaching the turbo scavenge pump to the accessory housing. Discard the lock washers.
- D. Remove the turbo scavenge pump and vacuum pump gasket from the accessory housing. Discard the vacuum pump gasket.

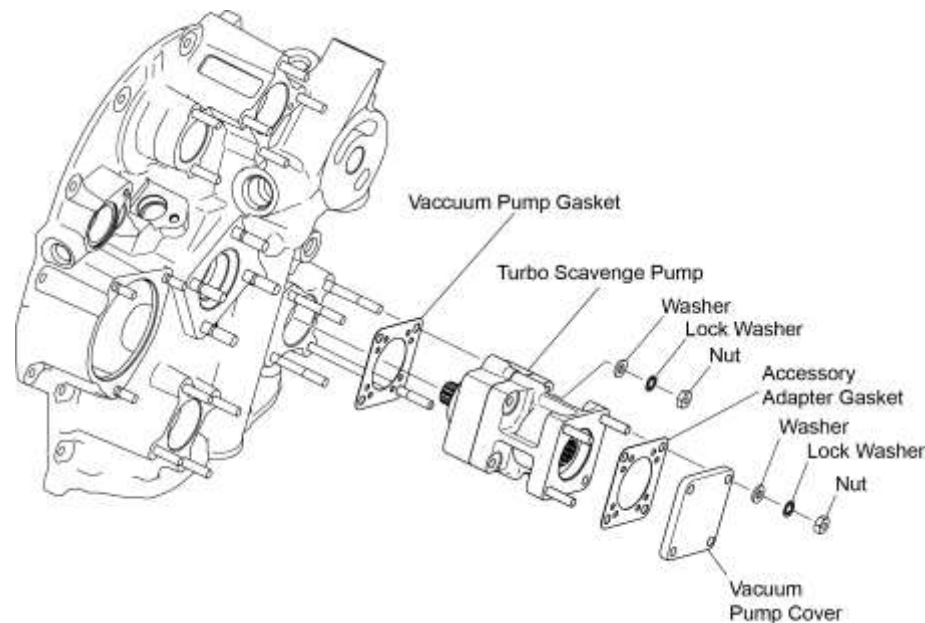


Figure 5
Turbo Scavenge Pump

5. Turbo Scavenge Pump Installation

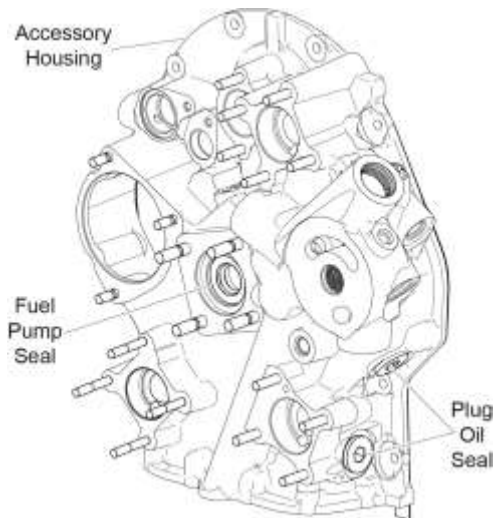
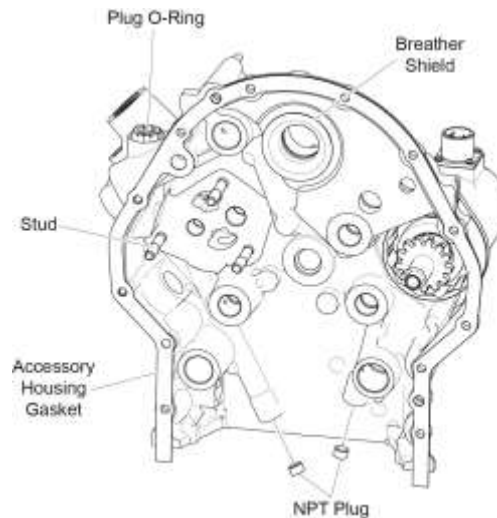
- A. Coat the splined drive shaft of the scavenge pump with Castrol[®] Moly Guard or equivalent.

NOTICE: Turn the drive shaft when installing the turbo scavenge pump to engage the spline in the turbo scavenge pump.

- B. Install a new vacuum pump gasket and the turbo scavenge pump on the studs in the accessory housing.
- C. Install the four washers, new lock washers, and nuts on the studs attaching the turbo scavenge pump to the accessory housing. Torque the nuts to 96 to 106 in.-lb. (11 to 12 Nm).
- D. Install a new accessory adapter gasket and the vacuum pump cover on the studs on the turbo scavenge pump.
- E. Install the four washers, new lock washers, and nuts on the studs attaching the vacuum pump cover to the turbo scavenge pump. Torque the nuts to 96 to 106 in.-lb. (11 to 12 Nm).

6. Accessory Housing Installation

- A. Examine plugs and fittings for damage. Replace any damaged plug or fitting.
- B. Install plugs, plug O-ring, plug oil seals, and seals in the accessory housing (Figures 6 and 7).


Figure 5
Plug Oil Seals in Accessory Housing

Figure 6
Plugs and Plug O-Ring in Accessory Housing

- C. Turn the crankshaft to position the cylinder 1 piston at TDC.
- D. Place a new accessory housing gasket (Figure 7) over the locating dowels on the rear of the crankcase.
- E. Apply a liberal coating of engine oil all contact surfaces, such as gear teeth and the idler gear hub.

NOTICE: Turn the crankshaft as necessary to move the gear train slightly so the oil pump drive gear will mesh with the idler gear and the accessory housing will seat against the crankcase and align on the dowel pins. Do not install the bolts if the accessory housing is not correctly seated against the crankcase.

- F. Fit the accessory housing into place on the rear of the crankcase.
- G. Install all bolts with plain washers and new lock washers (Figure 2). Torque the hardware per the Standard Torque Tables in the latest revision of the *Service Table of Limits - SSP-1776*.
- H. Install the fuel pump per instructions in Chapter 73-10 of this manual.
- I. Install all accessories removed during accessory housing removal on the accessory housing per airframe manufacturer's instructions.
- J. Install the turbo scavenge pump per instructions in this chapter.
- K. Connect the hose to the turbo scavenge pump. Torque the fitting per instructions in the Standard Torque Tables in the latest revision of the *Service Table of Limits - SSP-1776*.
- L. Install the PMA per instructions in Chapter 72-70 of this manual.
- M. Install the oil filter per instructions in Chapter 12-10.
- N. Connect the hoses to the airframe-supplied oil cooler.

72-30 - CYLINDER MAINTENANCE

1. General

- A. Complete the inspections identified in Table 1 at the regularly scheduled interval per instructions in this chapter.
- B. Record all findings and any corrective action on a copy of the respective Engine Inspection Checklists in Chapter 05-20 and in the checklists in this chapter as records of inspection.

Table 1
Regularly Scheduled Cylinder Inspections

Procedure	Frequency
Visual Cylinder Inspection	After every 100 hours of engine operation
Cylinder Compression Check	After every 100 hours of engine operation
Intercylinder Baffle Inspection	During every visual inspection
Cylinder Borescope Inspection	After every 400 hours of engine operation or as necessary for fault diagnostics
Exhaust Valve and Guide Inspection on TEO-540-A1A engines	After every 1000 hours of engine operation

2. Visual Cylinder Inspection

- A. Examine the cylinder and cylinder head (Figure 1) thoroughly for cracks, leaks, rust, pitting and/or damage. Replace a damaged, rusted, pitted, leaky or cracked cylinder per instructions in this chapter.
- B. Look for loose, damaged or leaking crankcase thru-studs. If loose, damaged or leaking crankcase thru-studs are found, send the engine to Lycoming Engines.
- C. Look for loose or damaged cylinder hold-down studs. If loose or damaged cylinder hold-down-studs are found, replace with appropriate oversize studs per Appendix A.
- D. Look for loose or damaged spark plug Heli-Coil[®] inserts. If a loose or damaged Heli-Coil[®] is found, replace the Heli-Coil[®] per the “Heli-Coil[®] Replacement” procedure in this chapter.
- E. Look for cracked or broken fins and baffles (Figure 1). If a cooling fin adjacent to the exhaust port flange is cracked, a 3/16 in. (4.76 mm) diameter hole can be drilled as a stop, under the following conditions:
 - The end of the crack is at least 1/4 in. (6.35 mm) from the base of the metal; or
 - The cracked area can be removed from the fin, provided the maximum removal is no more than one-half the total fin width; or
 - No burrs or sharp edges are in evidence; or
 - The minimum fillet at the root of the removed portion of the fin has a 1/4 in. (6.35 mm) radius, and the minimum corner at the top of the fin adjacent to the removed portion has a 1/2 in. (12.7 mm) radius; or
 - There is no more than one crack per fin and its depth is not longer than 1/4 in. (6.35 mm) from the base of the metal, and a fin stabilizer is used to reduce vibration and prevent further deepening of the crack.

- If a cooling fin is damaged, broken or bent, the bent area must not exceed 3/8 in. (9.53 mm) nor the break be 3/8 in. (9.53 mm) deep, or:
 - (1) There cannot be more than four blended fins on the push rod side of the head,
 - (2) No more than six blended fins on the anti-push rod side of the head.

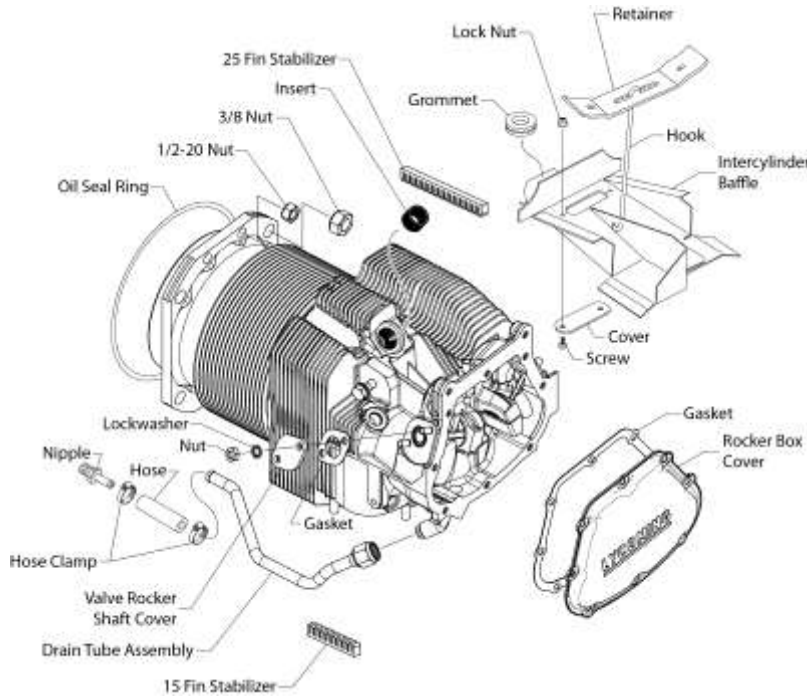


Figure 1
Engine Cylinder on TEO-540-A1A Engines

3. Cylinder Compression Check

- A. The Cylinder Compression Check is done on an installed engine and measures pressure leakage through the combustion chamber using a regulated pressure source and tester. It is essentially a cylinder leak-check procedure as an initial inspection of the condition of the engine cylinders. This procedure compares the static leak rate of the cylinder with the leak rate through an orifice of a specified range.
- B. The Cylinder Compression Check on the engine cylinders must be done at the following times or if the engine has any of these conditions:
 - After every 100 hours of engine operation or annual inspection
 - Difficulty starting
 - Increased oil consumption
 - Loss of power or unsteady power
 - Other indications of unusual operation.

A differential compression tester (Figure 2), attached to pressure gages is used for the Cylinder Compression Check. This tester operates with a given airflow through a fixed orifice and measures constant pressure drop across that orifice. This Cylinder Compression Check identifies leaks caused by incorrect valve seating, worn piston rings, damaged pistons or damaged cylinders. The static leak rate can indicate the condition of the parts in the combustion chamber. The leak rate is measured when pressure drops.

NOTICE: The orifice size of the differential compression tester is critical for consistent and meaningful cylinder analysis. A specific orifice size of 0.040 in. diameter (No. 60 drill) x 0.250 in. long, with entrance angle of 59°/60° supplies an acceptable calibrated leak rate. Larger orifice sizes can decrease the effectiveness of identifying problems.

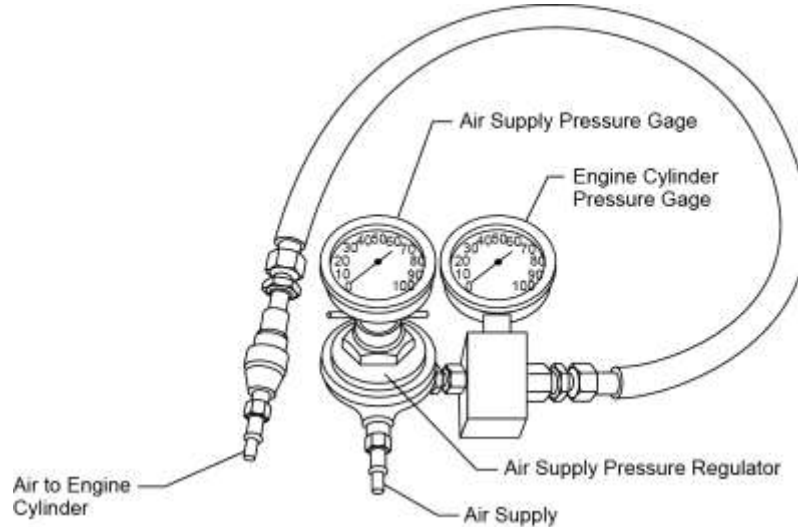


Figure 2
Example of a Differential Compression Tester

- (1) All differential compression testers must be in compliance with these specifications:
 - 0.250 in. long restrictor orifice
 - 0.040 in. ID (No. 61 drill) orifice diameter
 - 60° entrance angle
- (2) Make sure that all of the gauges to be connected to the differential compression tester are calibrated in accordance with the differential compression tester manufacturer's specifications.
- (3) Refer to the differential compression tester's manufacturer's instructions to ensure the tester operates correctly.

C. Cylinder Compression Check Procedure

NOTICE: Make sure the differential compression tester has been calibrated and the equipment check is complete per previous steps before this cylinder compression check.

This check is to be done on an engine installed in the airframe or test stand without interruption while the cylinder is still warm.

- (1) Immediately before the Cylinder Compression Check:
 - (a) Operate the engine at usual cylinder head and oil temperatures (specified in Appendix A of the *TEO-540-A1A Engine Installation and Operation Manual*).
 - (b) Put the power control in the IDLE CUT-OFF position.
 - (c) Move the ignition switch to the OFF position to shut down the engine.

- (d) Pull the EECS power circuit breaker.
- (e) Make sure that the aircraft master switch and fuel supply switches are all in the OFF position.
- (f) After the engine is shut down, complete the Cylinder Compression Check immediately to get an accurate measurement.
- (g) Set the aircraft brakes and install the wheel chocks.

⚠ CAUTION TAKE ALL NECESSARY PRECAUTIONS AGAINST ACCIDENTAL ROTATION OF THE CRANKSHAFT/PROPELLER TO PREVENT INJURY.

- (2) Disconnect the battery.

⚠ CAUTION IGNITION LEADS AND SPARK PLUGS ARE VERY HOT. IN THE NEXT STEP, WEAR PERSONAL PROTECTIVE GEAR TO PREVENT BURNS.

- (3) Disconnect all of the spark plugs leads per the “Spark Plug Removal” procedure in Chapter 74-20.
- (4) Remove a spark plug from each cylinder. Discard the spark plug gasket.

⚠ CAUTION USE GLOVES OR RAGS TO PROTECT HANDS WHILE HOLDING THE PROPELLER BLADE.

- (5) Turn the crankshaft by hand in the direction of propeller rotation to put the piston in a position as close to Top Dead Center (TDC) on the compression stroke as possible.
- (6) Install the threaded end of an adapter with a coupling end in the spark plug hole of the cylinder to be tested.
- (7) Make sure that the air valve on the differential compression tester is in the CLOSED position.
- (8) Connect the differential compression tester to the adapter and to a clean source of compressed air.

⚠ CAUTION BEFORE CONNECTION OF THE COMPRESSION TESTER, MAKE SURE THAT THE AIR SUPPLY REGULATOR DOES NOT SHOW MORE THAN 80 PSI (552 KPA) OF AIR PRESSURE. EXCESSIVE AIR PRESSURE CAN CAUSE THE PROPELLER TO TURN. KEEP CLEAR OF THE ROTATIONAL RADIUS OF THE PROPELLER.

NOTICE: Operate the differential compression tester per the manufacturer’s instructions.

- (9) Adjust the regulator of the compression tester to 0 psi (0 kPa) on the regulated pressure gage.
- (10) Connect the differential compression tester to the adapter in the spark plug hole of the cylinder to be tested.
- (11) One mechanic holds the propeller firmly in place, to prevent crankshaft rotation, while the other mechanic opens the cylinder pressure valve in the next step.

⚠ WARNING IN THE NEXT STEP, HOLD THE PROPELLER FIRMLY WHEN OPENING THE AIR VALVE ON THE DIFFERENTIAL COMPRESSION TESTER. PENT-UP AIR PRESSURE IN THE CYLINDER COULD CAUSE THE CRANKSHAFT TO TURN.

- (12) Slowly open the air valve on the differential compression tester and increase the pressure to the cylinder to 15 to 20 psi (103 to 138 kPa).
- (13) Listen for escaping air. If escaping air is heard, refer to Table 2 to identify and correct the cause.
- (14) Continue to turn the propeller in the usual direction of rotation against the 15 to 20 psi (103 to 138 kPa) pressure until the piston reaches TDC evident by a sudden decrease in the force necessary to turn the propeller.

NOTICE: If you turn the propeller past TDC, back up the rotation at least one revolution and repeat the previous step to prevent backlash and to keep the piston rings in position.

- (15) With the piston at TDC, one mechanic holds the propeller securely while the other mechanic opens the air valve slowly and completely. Gradually increase the air supply pressure up to 80 psi (552 kPa). As the pressure increases, the other mechanic must move the propeller back and forth slightly with a rocking motion to make sure that the piston rings are seated.
- (16) Record the pressure reading on the engine cylinder pressure gage. The difference between the engine cylinder pressure gage reading and the pressure shown on the air supply pressure gage reading is the amount of leakage through the cylinder.
- (17) The minimum approved engine cylinder pressure reading is 60 psi (414 kPa). Maximum approved leakage is 25% (20 psi (138 kPa) of the 80 psi (552 kPa) regulated pressure).
- (18) Close the air valve and disconnect the differential compression tester from the engine cylinder and connect it to the spark plug hole of the next engine cylinder to be tested.

NOTICE: Pressure readings for all of the engine cylinders are to be nearly equal. Refer to Table 2.

- (19) Complete the previous steps for each of the remaining engine cylinders.
 - (20) Refer to Table 2 for a summary of the Cylinder Compression Check results and corrective action. Corrective action in Table 2 applies to procedures in this chapter.
- D. Review and analyze the results. Take any necessary corrective action.
- E. Record the results of the Cylinder Compression Check for each cylinder on the 100-Hour or Annual Engine Inspection Checklist (in Chapter 05-20).
- F. After all service is complete, examine and install the spark plugs with a new gasket and connect the ignition leads to the spark plugs per the following procedures in Chapter 74-20.
- Spark Plug Inspection
 - Spark Plug Rotation
 - Ignition Lead Inspection
 - Spark Plug Installation
 - Spark Plug Gap Setting

Table 2
Summary of Cylinder Compression Check Results and Corrective Action

Results	Indication	Corrective Action
Differential pressure of 70 psi (483 kPa) or more for an engine cylinder	Satisfactory	No corrective action necessary.
Differential pressure of 60 to 69 psi (414 to 441 kPa) for an engine cylinder	Wear has occurred	Complete the Cylinder Compression Check again after the next 100-hour engine operating interval - record results. Monitor the differential pressure.
Differential pressure of less than 60 psi (413 kPa) for an engine cylinder	Cylinder worn or not in conformance	Either manually turn the crankshaft three times or start the engine and operate for 3 minutes, stop the engine, and repeat the Cylinder Compression Check. If the results of the second Cylinder Compression Check are too low, listen for airflow at the exhaust and intake ports. Identify all of the causes and complete the necessary corrective action.
Difference of 5 psi (34 kPa) or less) between engine cylinders (Pressure readings for all engine cylinders must be nearly equal.)	Satisfactory	No corrective action necessary.
Difference of 6 to 15 psi (41 to 103 kPa) between engine cylinders.		Repeat the Cylinder Compression Check after the next 10 hours of engine operation. A valve can reseal itself and show satisfactory compression again. If the difference remains between 6 to 15 psi (41 to 103 kPa) after the second Cylinder Compression Check, identify all of the causes and complete the necessary corrective action.
Difference of more than 15 psi (104 kPa) between engine cylinders		Start and operate the engine for 3 minutes, stop the engine, and repeat the Cylinder Compression Check. If the difference between engine cylinders is still more than 15 psi (104 kPa) , replace all of the engine cylinders.
Air escaping at spark plug spot face	Fluorescent Penetrant Inspection of area shows cracks	Replace the cylinder with a cylinder kit.
Leak check at the spark plug port seals (using a soap solution) shows bubbling around spark plug port seal.	Heli-Coil [®] insert requires replacement.	Complete the "Heli-Coil [®] Replacement" procedure in this chapter.

**Table 2 (Cont.)
Summary of Cylinder Compression Check Results and Corrective Action**

Results	Indication	Corrective Action
Air discharge at cylinder head-to-barrel juncture or between barrel fins.		Replace the cylinder with a cylinder kit.
Air discharged through the breather or oil filler tube.	Leakage in the area of the piston and rings.	Complete the “Piston Inspection” in this chapter.
Air discharged through the intake system	Cracked cylinder	Replace the cylinder with a cylinder kit.
	Intake valve and/or seat worn or burnt Leakage at the intake valve	Examine the intake valve and valve seat for wear or burns. Replace worn or burnt intake valve or intake valve seat.*
Air discharged through the exhaust system	Cracked cylinder	Replace the cylinder with a cylinder kit.
	Exhaust valve and/or seat worn or burnt Leakage at the exhaust valve	Examine the exhaust valve and valve seat for wear or burns.* Replace worn or burnt exhaust valve or exhaust valve seat.*
* Either replace the cylinder or send the engine cylinder to an authorized vendor to replace the valve seat.		

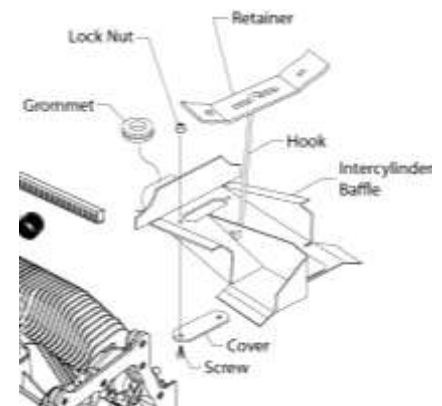
4. Intercylinder Baffle Inspection

NOTICE: This inspection can be done while the intercylinder baffles are installed on the engine.

- A. This inspection is done during the visual inspection to look for premature cylinder deterioration and make sure that intercylinder baffles are correctly fitted and installed. The intercylinder baffles are necessary to prevent rapid deterioration of the cylinders and other engine components because they transfer heat in piston engines. To ensure this cooling, the intercylinder baffles must be installed intact and operating correctly.

B. Intercylinder Baffle Inspection Procedure

- (1) Examine the intercylinder baffle (Figure 3) and surrounding components for damage, holes, cracks, wear, deterioration, and incorrect position. Replace a damaged, worn, cracked or deteriorated intercylinder baffle per the “Intercylinder Baffle Removal” and Intercylinder Baffle Installation” procedures in this chapter.
- (2) Tighten any loose intercylinder baffle fasteners per the latest revision of the *Service Table of Limits SSP-1776*.
- (3) Correct the intercylinder baffle position as necessary.
- (4) Record results of this inspection and any corrective action taken on the Visual Inspection Checklist in Chapter 05-20.



**Figure 3
Intercylinder Baffle**

5. Cylinder Borescope Inspection

▲ WARNING DURING A CYLINDER BORESCOPE INSPECTION, MAKE SURE THAT THE IGNITION SWITCH IS TURNED OFF AND THAT POWER TO THE ENGINE IS DISCONNECTED.

AS A PRECAUTION, DO NOT STAND OR ALLOW ANYONE TO STAND WITHIN THE ROTATIONAL ARC RADIUS OF THE PROPELLER. MAKE SURE THE ENGINE IS COOL.

- A. The cylinder borescope inspection is done to examine the inner walls of the engine cylinders for rust, deposits and unusual wear patterns of the combustion chamber, valve, piston top, and the cylinder barrel without removing the engine cylinder.
- B. When to complete the Cylinder Borescope Inspection:
 - (1) Repeatedly high oil consumption is excessive
 - (2) 400-hour inspection
 - (3) After an engine overspeed
 - (4) Low cylinder compression
 - (5) If valve sticking is suspected (refer to the “Corrective Action for Valve Sticking” section in this chapter)
 - (6) Worn piston rings or worn cylinder barrel
 - (7) Insufficient combustion
- C. Cylinder Borescope Inspection Procedure
 - (1) Remove a top spark plug from each cylinder per the “Spark Plug Removal” procedure in Chapter 74-20.
 - (2) Put the piston at bottom dead center on the power stroke.
 - (3) Install the borescope through the vacant top spark plug hole on the engine cylinder and examine the combustion chamber, the top of the piston, the internal surfaces of each cylinder, including the exhaust valve and exhaust valve seat. Complete inspection steps in Table 3.
 - (4) Remove the borescope from the cylinder.
 - (5) Put the piston at bottom dead center at the end of the intake stroke.
 - (6) Install the borescope through the vacant spark plug hole and examine the intake valve and intake valve seat. Complete inspection steps in Table 3. Unless otherwise shown, corrective action in Table 3 applies to procedures in this chapter.
 - (7) Reinstall the spark plug in the cylinder per the “Spark Plug Installation” procedure in Chapter 74-20.
 - (8) Record all results and corrective action in the 400-Hour Engine Inspection Checklist in Chapter 05-20 or the engine logbook.

Table 3
Borescope Inspection Steps, Results, and Corrective Action

Inspection Step	If these are the results...	Take this corrective action...
Examine valve seat inserts for scoring, pitting, erosion, burning or damage	Eroded, scored, burnt, pitted or damaged valve seats	Replace the cylinder or send the engine cylinder to an authorized vendor to replace the valve seat.
Examine spark plug Heli-Coils® for protrusion into the combustion chamber	Spark plug Heli-Coil® protrudes into combustion chamber	Replace the Heli-Coil® per the “Heli-Coil® Replacement” procedure in this chapter.
Look for discoloration on the circumference of the exhaust valve face	Discoloration on the circumference of the exhaust valve face	Remove and examine the exhaust valve.
Look for cracks and erosion on the exhaust valve face	Cracks or erosion on the exhaust valve face	Remove and examine the exhaust valve.
Look for discoloration on the circumference of the intake valve face	Discoloration on the circumference of the intake valve face	Remove and examine the intake valve.
Look for cracks and erosion on the intake valve face	Cracks or erosion on the intake valve face	Replace the intake valve.
Examine the cylinder bore for scoring, rubbing, or corrosion	Scoring or piston rub or corrosion on cylinder bore	Remove and examine the engine cylinder. Remove and examine the oil suction screen and the oil filter per instructions in Chapter 12-10.
Look for excessive oil in the cylinder	Excessive oil in the cylinder	Remove and examine the engine cylinder. Remove and examine the oil suction screen and the oil filter per instructions in Chapter 12-10.
Examine the piston crown for erosion or damage	Erosion or damage on piston crown	Remove the engine cylinder and examine the piston.

6. Exhaust Valve and Guide Inspection

On TEO-540-A1A engines, this inspection is to be done after every 1000 hours of engine operation or earlier if valve sticking is suspected.

NOTICE: If valve sticking is a problem, this inspection must be done every 400 hours. Refer to “Corrective Action for Valve Sticking” in this chapter.

Sticking between the valve stem and guide (on intake and exhaust valves) can substantially change valve opening and closing. If the valve cannot open or close correctly, incomplete combustion will occur, which can cause formation of more deposits and increased valve sticking. Because a correctly-timed sequence of valve opening and closing is essential to efficient and reliable engine operation, the cause of valve sticking must be identified and corrected.

⚠ WARNING A STUCK VALVE CAN CAUSE ENGINE DAMAGE.

NOTICE: If one valve is sticking, examine all intake and exhaust valves on all of the engine cylinders.

The exhaust valve and guide must be examined to measure valve stem movement to identify excessive wear (bell-mouthing) of the exhaust valve guide and carbon build-up between the valve guide and valve stem which can cause valve sticking

Refer to the latest revision of Service Bulletin No. SB-388, Service Instruction No. SI-1485, and Service Letter L197 for additional details.

NOTICE: The Gage (ST-310) is used to examine angular-type valves on engine cylinders. Although Gage (ST-310) and a feeler gage can be used to measure valve stem movement, a modified Gage (ST-310) (Figure 4) and a dial indicator are a faster and easier means to measure valve stem movement, valve guide wear, and carbon build-up per this procedure.

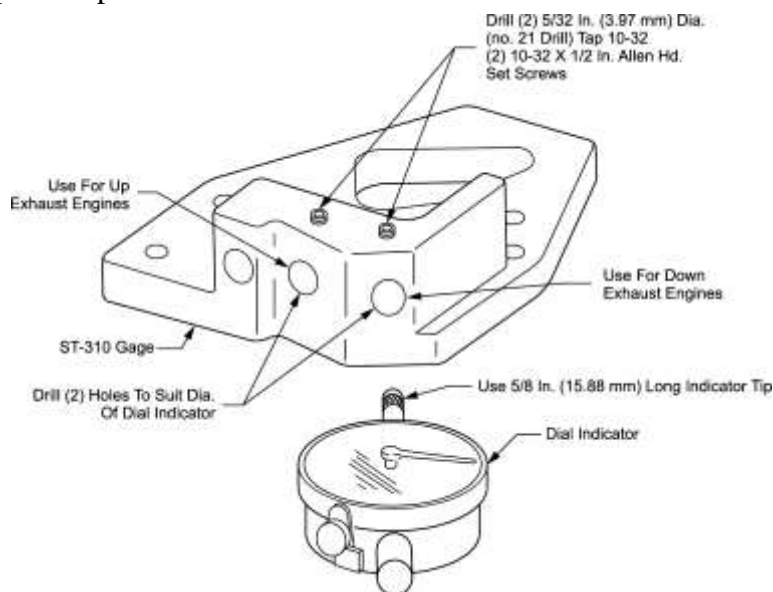


Figure 4
Details for Modifying Tool P/N ST-310

NOTICE: Do not intermix valve and cylinder components between cylinders. Re-install serviceable parts in the same cylinder.

A. Examine the exhaust valve and guide on each cylinder as follows:

- (1) Disconnect the battery.
- (2) Make sure the engine is cool.
- (3) Remove the screws, rocker box cover (Figure 5) and gasket from the cylinder head. Discard the gasket.
- (4) Remove the nuts, lock washers, valve rocker shaft cover, and valve rocker shaft cover gasket. Discard the lock washers and valve rocker shaft cover gasket.
- (5) Remove the valve rocker shaft, valve rocker shaft bushing, rocker assembly, and washer.

- (6) Remove the valve stem cap from the exhaust valve.
- (7) Remove and examine the valve stem keys which tend to wear in uniform distinctive patterns. Replace worn or damaged valve stem keys. If the keys do not need to be replaced, install them in the same position from where they were removed.

⚠ CAUTION DO NOT MIX PLUNGER ASSEMBLIES WITH DIFFERENT PART NUMBERS IN THE SAME ENGINE. DIFFERENT PLUNGERS HAVE VARYING LEAK DOWN RATES WHICH CAN CAUSE INCORRECT ENGINE OPERATION.

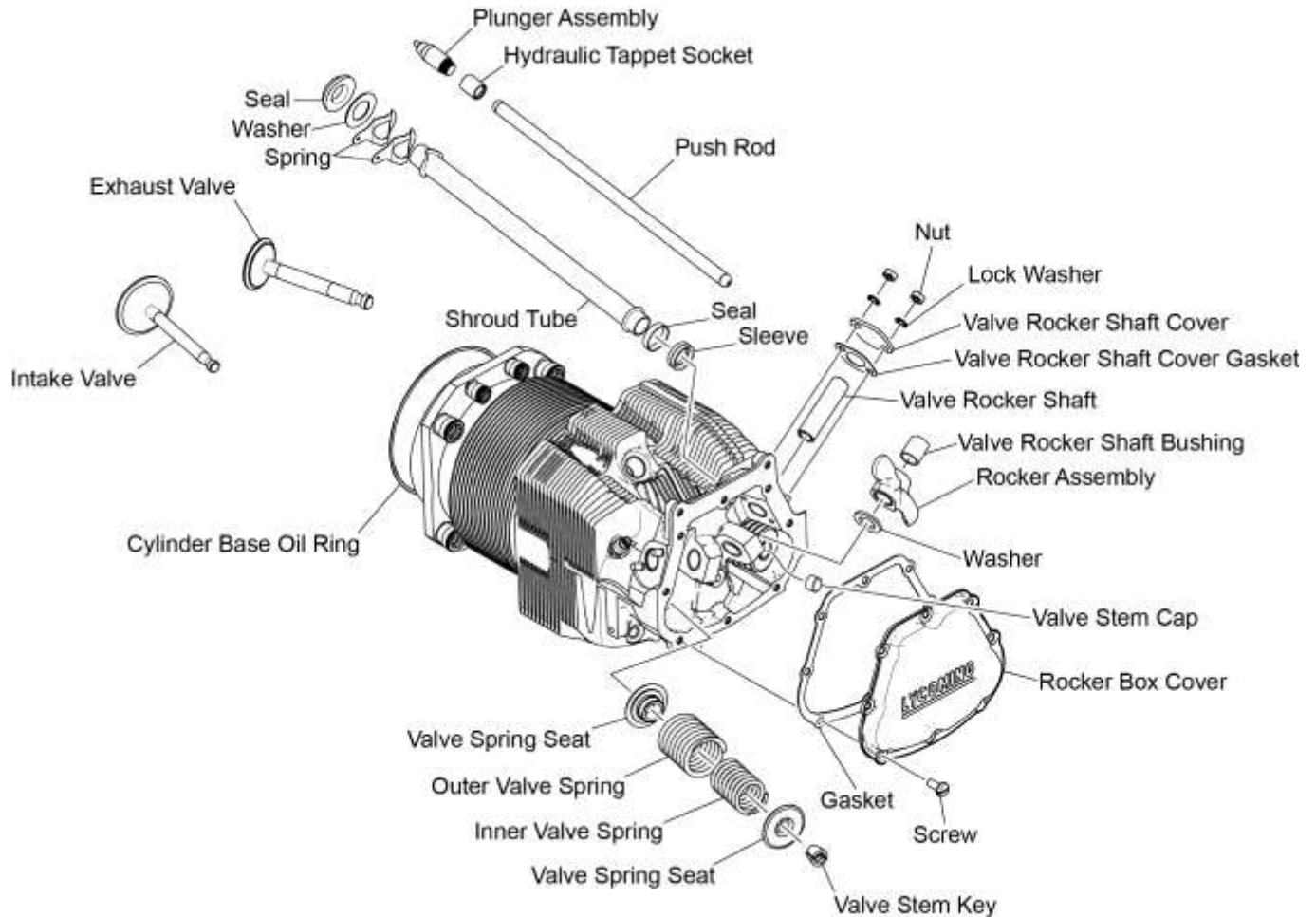


Figure 5
TEO-540-A1A Engine Valve Components

- (8) Remove all of the push rods, shroud tubes, hydraulic tappets, plunger assemblies, sleeve, springs, washers, and seals from the engine cylinder.
- (9) Use a cloth dampened with mineral spirits to wipe the oil from the top surface of the valve spring seat on the exhaust valve (Figure 5).
- (10) Loosen the screws identified in Figure 6 to prevent the screws from touching the Gage Adapter (ST-310-9) when installed on the valve stem.

- (11) Install the Gage (ST-310) on the valve on the cylinder head as shown in Figure 6.
- (12) Tighten the cap screws (identified in Figure 6) equally. If the casting touches the lower cap screw, put the washer under the head.
- (13) Measure stem movements by moving the valve stem along the valve guide wear line (inside diameter of the valve guide, parallel to the centerline of the valve rocker arm).

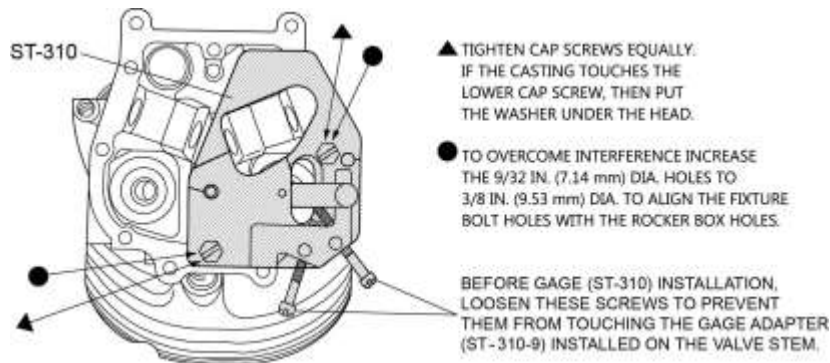


Figure 6
Gage ST-310 Installation on the Cylinder Head

- (14) Install the Gage Adapter (ST-310-9) over the top of the valve stem (Figure 7). Make sure it is tight.

NOTICE: If you can move the Gage Adapter (ST-310-9) on the valve stem with your hand, it is incorrectly installed.

- (15) Push the valve stem and Gage Adapter (ST-310-9), against the upper spring retainer as far as they will go.
- (16) Put the blade of a screwdriver in the area between the exhaust valve spring and Gage (ST-310).

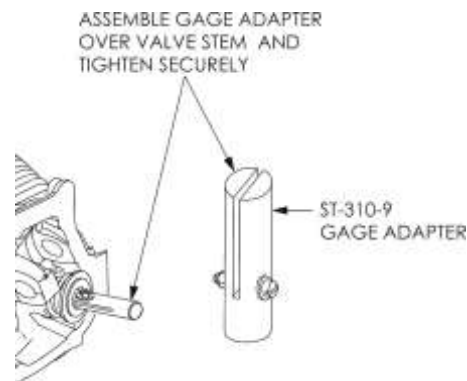


Figure 7
Gage Adapter (ST-310-9)
Assembled on Exhaust System

- (17) Use the screwdriver to push the valve and adapter the maximum distance away from the dial indicator as shown in Figure 8.
- (18) Move the dial indicator toward the adapter post until the indicator is preloaded approximately 0.010 in. (0.254 mm), and lock it in place with the set screw.
- (19) Adjust the dial of the indicator to read "0" (zero).

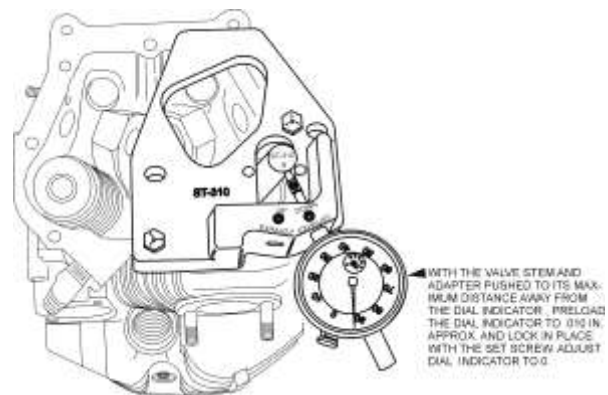


Figure 8
Dial Indicator

- (20) Insert the screwdriver between the Gage (ST-310) and valve spring on the opposite side and push the valve spring toward the dial indicator as shown in Figure 9.
- (21) Relax the screwdriver and record the reading on the dial indicator. For the valve guide to be acceptable, the measurement must be within the specified limits in the latest revision of the *Service Table of Limits - SSP-1776*.

AFTER THE DIAL INDICATOR HAS BEEN PRELOADED USE A SCREWDRIVER TO MOVE VALVE STEM TOWARD DIAL INDICATOR. RELAX PRESSURE ON SCREWDRIVER AND RECORD INDICATOR READING. INDICATOR READING MUST BE WITHIN LIMITS SHOWN IN TABLE.

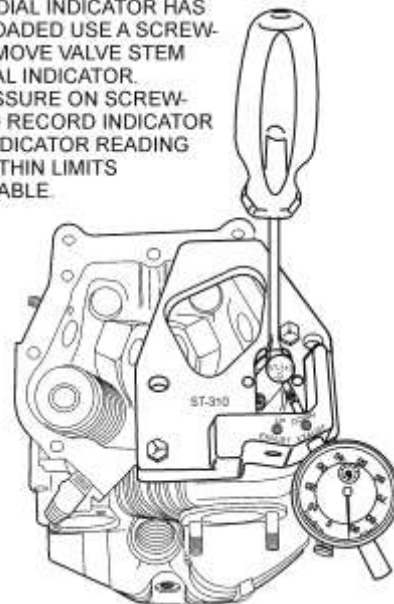


Figure 9
Pushing Valve Stem and Adapter Post
Toward Dial Indicator

- If the measurement is greater than the specified limit, either replace the cylinder or send the cylinder to an authorized vendor who can replace the valve guide.
 - If the measurement is less than the specified limit, ream the valve guide per instructions in the latest revision of Service Instruction No. SI-1425.
- (22) Move the piston to near its top end of travel.
- (23) Remove the Gage Adapter (ST-310-9) from the valve stem.
- (24) Loosen each cap screw in the Gage (ST-310) (Figure 6) in small equal increments to decrease pressure on the valve spring slowly and equally.
- (25) Remove the Gage (ST-310) from the cylinder.
- (26) Repeat this exhaust valve and guide inspection for all cylinders.
- (27) Record all of the results in the 1000-Hour Inspection Checklist for TEO-540-A1A engines in Chapter 05-20.

⚠ CAUTION DO NOT MIX PLUNGER ASSEMBLIES WITH DIFFERENT PART NUMBERS IN THE SAME ENGINE. DIFFERENT PLUNGERS HAVE VARYING LEAK DOWN RATES WHICH CAN CAUSE INCORRECT ENGINE OPERATION.

- (28) If removed, examine and install acceptable plunger assemblies and hydraulic tappets in the correct location. Refer to the latest revision of Service Instruction SI-1011 for plunger assembly inspection guidelines.
- (29) Install all of the seals, washers, sleeve, springs, shroud tubes, and push rods (Figure 5) on the cylinder.

NOTICE: The valve stem cap on the exhaust valve stem is a rotator type and different than the valve stem cap on the intake valve.

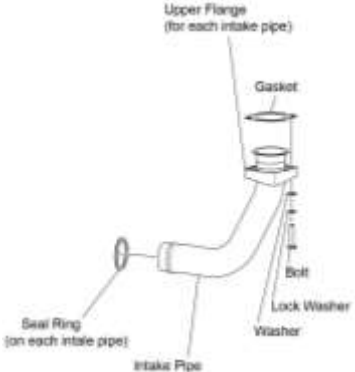
- (30) Install the rotator type valve stem cap (Figure 10) on the exhaust valve stem and the intake valve stem cap on the intake valve.
- (31) Install the rocker assembly, washer, and exhaust valve rocker shaft (Figure 5).
- (32) Install the valve rocker shaft cover with a new valve rocker shaft cover gasket, new lock washers and nuts.
- (33) Install the screws, rocker box cover with a new gasket on the cylinder head (Figure 5). Torque the screws per the Standard Torque Tables in the latest revision of the *Service Table of Limits - SSP-1776*.
- (34) Reconnect the battery.
- (35) Complete the “Operational Ground Check” in Chapter 72-00.

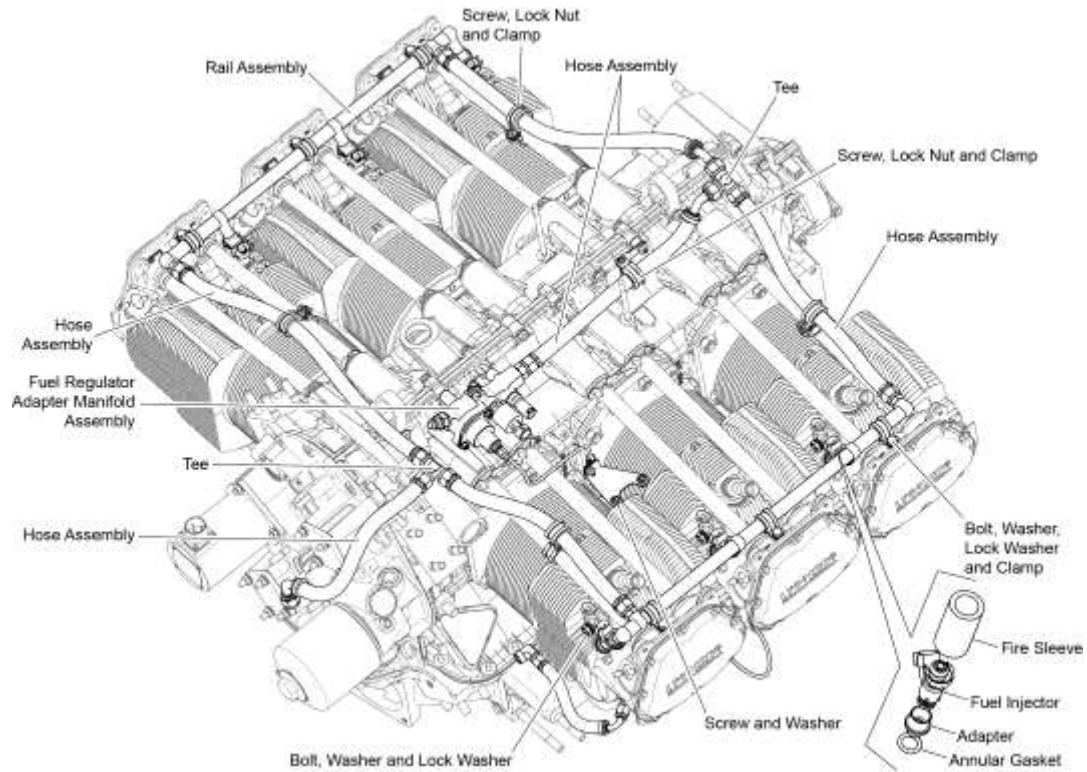


Figure 10
Exhaust Valve Stem Cap

7. Cylinder Removal

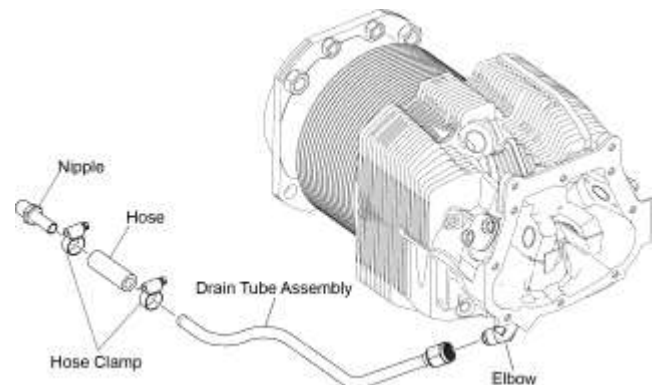
- A. Disable all power to the engine and disconnect the engine wiring harness from the airframe per instructions in the “Engine-to-Firewall Wiring Harness Removal” section in Chapter 72-70.
- B. If not already done:

<ul style="list-style-type: none"> • Remove airframe components to enable cylinder removal 	<p>Airframe Maintenance Manual</p>
<ul style="list-style-type: none"> • Drain the oil from the oil sump. • Disconnect the ignition leads to the spark plugs. Remove the top and bottom spark plugs from the cylinder. 	<p>“Oil Change Procedure” in Chapter 12-10 “Spark Plug Removal” procedure in Chapter 74-20.</p>
<ul style="list-style-type: none"> • Remove the intake pipe (Figure 11) and exhaust pipe from the cylinder to be removed. 	<p>“Intake Pipe Removal” procedure in Chapter 72-80 and the airframe manufacturer’s instructions.</p> <div style="text-align: right;">  </div> <p style="text-align: center;">Figure 11 Intake Pipe</p>
<ul style="list-style-type: none"> • Remove the clamps that attach the fuel hose to the shroud tube (Figure 12), remove the Fuel Injector Rail Assembly (which will also remove the fuel injector.) 	<p>“Fuel Injector Rail Assembly Removal” procedure in Chapter 73-10.</p>

**Figure 12****Fuel Injector Rail Assembly and Fuel Injectors****C. Oil Drain Tube Removal**

NOTICE: There are different part numbers for some of the oil drain tube assemblies. Apply a label to identify the location of each oil drain tube, in case the drain tube is to be replaced. Refer to the *TEO-540-A1A Illustrated Parts Catalog* for the correct part number for the oil drain tube.

- (1) Remove the hose clamps (Figure 13) from hose attached to the oil drain tube assembly.
- (2) Disconnect the hose from the nipple.
- (3) Disconnect the drain tube fitting from the engine cylinder.
- (4) Remove and discard the hose (Figure 13).
- (5) Remove the drain tube assembly from the cylinder.
- (6) Examine the drain tube for cracks or damage.
- (7) Replace a cracked or damaged drain tube assembly.

**Figure 13**
Oil Drain Tube

NOTICE: Remove the cylinders by firing order 1- 4- 5- 2- 3- 6 (Figure 14). Remove each cylinder as an assembly.

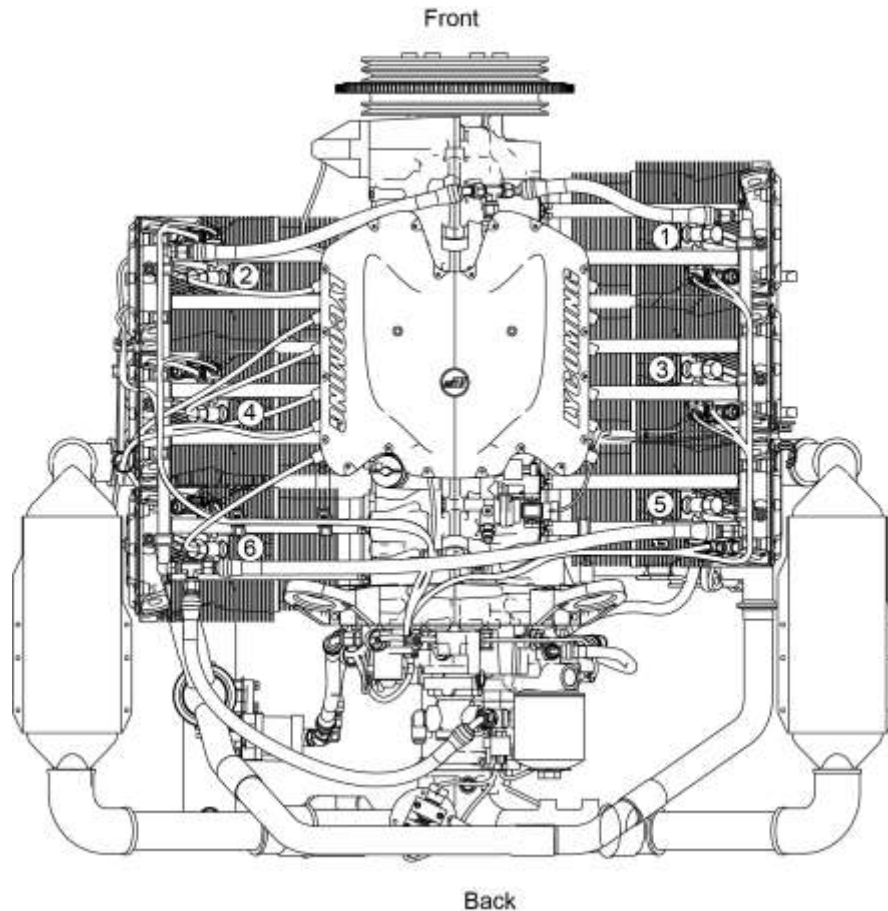


Figure 14
Engine Cylinder Firing Order

NOTICE: During cylinder removal, identify and label the cylinder, piston, and other parts by location (i.e., cylinder number) as they are removed for reference on assembly (to ensure that each serviceable part is installed in the same location from which it was removed).

D. Intercylinder Baffle Removal

- (1) Turn the baffle retainer hook to disengage the retainer on the intercylinder baffle (Figure 15).
- (2) Remove the intercylinder baffle and hook from between the cylinders.

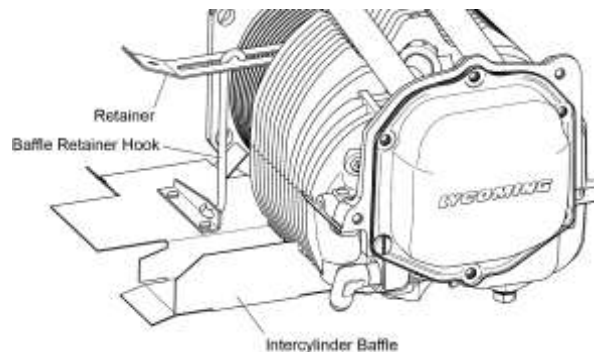


Figure 15
Intercylinder Baffles

CAUTION USE CAUTION WHEN TOUCHING THE SENSORS AND ACTUATORS. THEY CAN BE EASILY DAMAGED. NONE CAN BE REPAIRED. IF ANY OF THESE ITEMS ARE DAMAGED, THEY MUST BE REPLACED.

E. Disconnect and remove the Knock Sensor (Figure 16) and Cylinder Head Temperature Sensor (Figure 17) from the engine cylinder. Refer to the "Sensor Replacement Procedures" in Chapter 72-70.

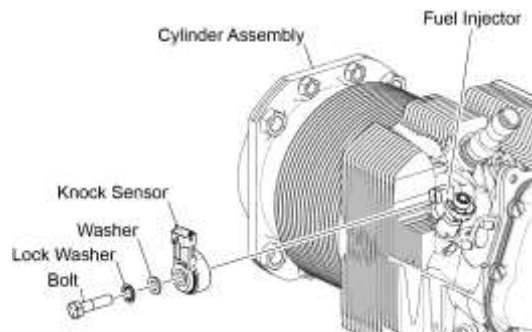


Figure 16
Knock Sensor
on the Engine Cylinder

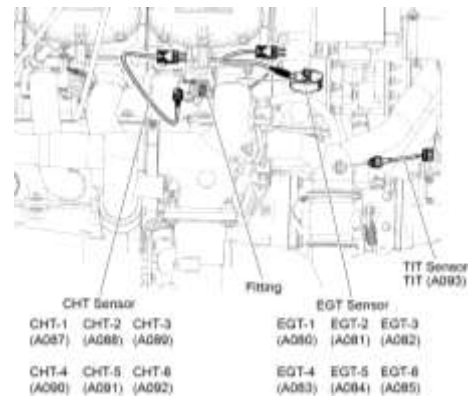


Figure 17
Cylinder Head Temperature Sensor
on the Engine Cylinder

F. Remove the screws from the rocker box cover (Figure 18).

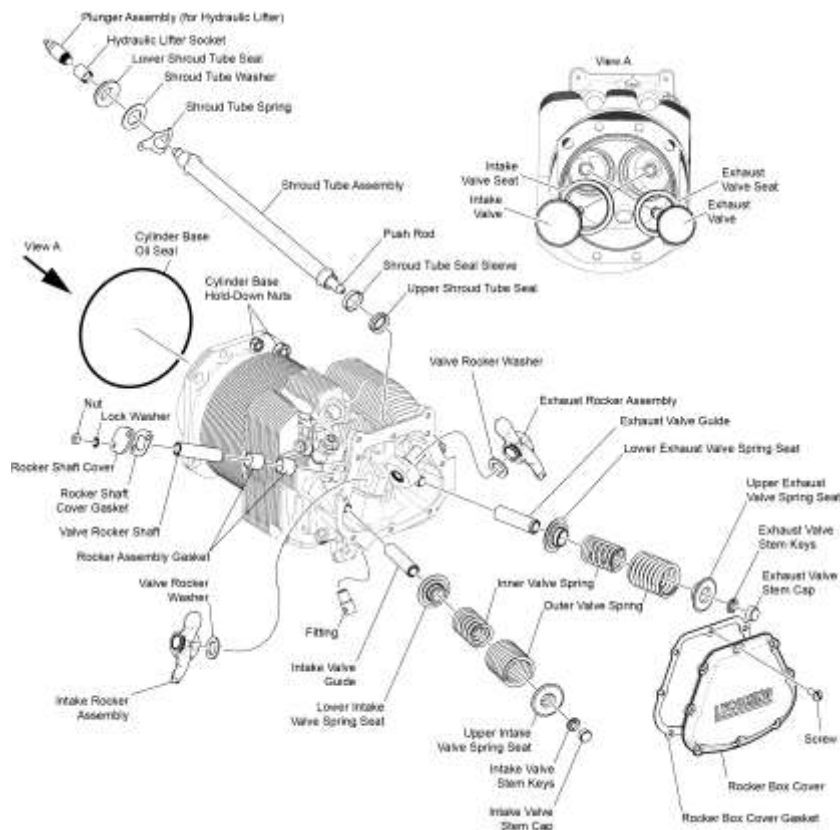


Figure 18
TEO-540-A1A Engine Valve Components

- G. Remove the rocker box cover (Figure 18) and gasket. Discard the gasket.
- H. Remove the nuts and lock washers from the rocker shaft covers. Discard the lock washers.
- I. Remove the rocker shaft covers, and rocker shaft cover gaskets. Discard the gaskets.
- J. Turn the crankshaft to put the piston at TDC of the compression stroke of the cylinder to be removed. (With the piston in this position, both intake and exhaust valves are closed and the piston is extended away from the crankcase to prevent damage when the cylinder is removed.).

NOTICE: Do not remove valve rocker shafts until the cylinder is removed from the engine.

- K. Push the valve rocker shafts (Figure 18) outward and remove the rocker assemblies and bushings.
- L. Remove the push rods and the valve stem caps from the intake and exhaust valves.
- M. Using the Shroud Tube Wrench (ST-142), turn each shroud tube 90° in either direction to release the tube from the spring.
- N. Remove the shroud tubes by first releasing them from the seal seats in the cylinder head and withdrawing the tubes.
- O. Remove the seals from the ends of the shroud tubes. Discard the seals.
- P. Remove the seals from the crankcase. Discard the seals.
- Q. Remove the valve stem keys, valve spring seats, and valve springs.

CAUTION AS THE CYLINDER IS SEPARATED FROM THE CRANKCASE, CATCH AND HOLD THE PISTON TO PREVENT IT FROM FALLING AGAINST THE CRANKCASE AND BEING DAMAGED.

- R. Remove the cylinder base hold-down nuts (Figure 18).
- S. Remove the cylinder.
- T. Remove the cylinder base oil ring from the cylinder (Figure 19) and (as an option) keep it to use as support for the connecting rods after the pistons are removed.
- U. Remove the valve rocker shaft (Figure 18) from the engine cylinder

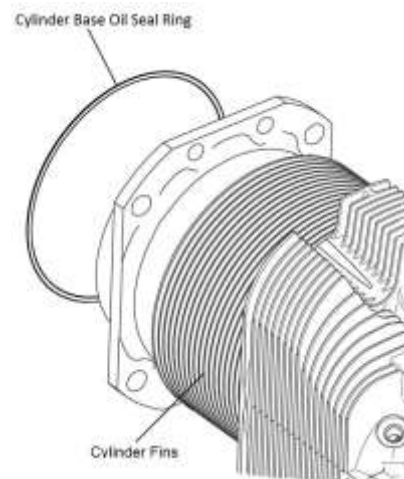


Figure 19
Cylinder Base Oil Ring and Cylinder Fins

CAUTION IF A CYLINDER IS NOT TO BE IMMEDIATELY INSTALLED ON THE CRANKCASE, INSTALL TORQUE HOLD-DOWN PLATES (ST-222) TO MAINTAIN THE PRE-LOAD ON THE MAIN BEARINGS.

NOTICE: Examine the connecting rod bushing for damage, wear and correct installation every time a cylinder is removed.

8. Piston Removal

NOTICE: During removal of each piston pin (Figure 20), the piston will disconnect from the connecting rod. Support the connecting rod to prevent damage to the connecting rod and crankcase.

- A. Support the piston and remove the two piston pin plugs (Figure 20) and piston pin from the piston.

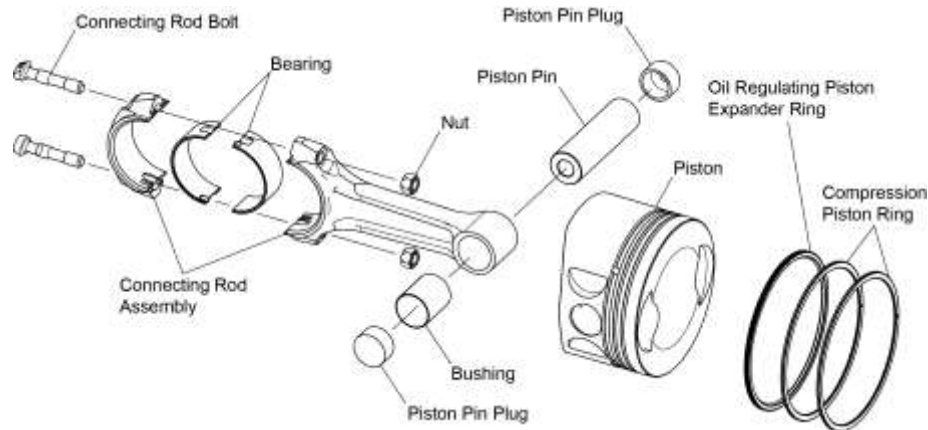


Figure 20
Piston Assembly

- B. Remove the piston from the connecting rod.
- C. Support the connecting rod one of two ways to prevent damage to the connecting rods and crankcase:
- (1) Install Torque Hold-Down Plates (ST-222) as shown in Figure 21.
- OR
- (2) Make a loop around the cylinder base studs and connecting rod using a rubber band or the cylinder base oil seal ring (removed during cylinder removal) as shown in Figure 22.

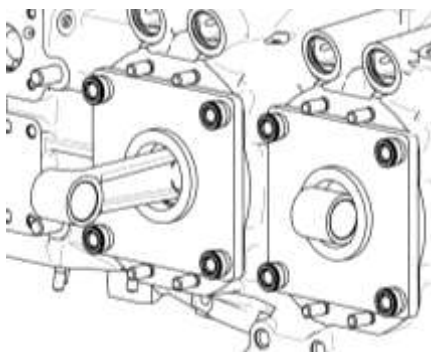


Figure 21
Torque Hold-Down Plates (ST-222)

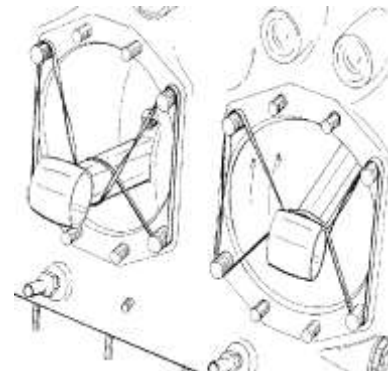


Figure 22
Loop Cylinder Base Oil Seal Around Cylinder Base Studs and on Connecting Rods

CAUTION DURING REMOVAL OF THE THREE PISTON RINGS IN THE NEXT STEP, USE CARE NOT TO SCRATCH THE PISTON.

- D. Start from the top down, use the Piston Ring Expander (P/N 64713) to remove the two top compression rings and the oil regulating piston expander ring (Figure 20).

9. Cylinder Assembly Inspection

Copy and complete the Cylinder Assembly Inspection Checklist for TEO-540-A1A Engine Models.

Cylinder Assembly Inspection Checklist for TEO-540-A1A Engine Models		
Engine Serial Number: _____ Engine Time: _____		
Date Inspection Done: _____ Inspection done by: _____		
Item to Examine and Corrective Action	Cylinder No.	Findings / Corrective Action
Look for wear or broken parts in the area of the valve, springs, and spring seats. Corrective Action: Replace any broken or worn parts. (Figure 18).	Cylinder 1	
	Cylinder 2	
	Cylinder 3	
	Cylinder 4	
	Cylinder 5	
	Cylinder 6	
Examine the intake and exhaust valve seats for looseness, scoring, pitting damage or non-conformities. Look for cracked or eroded valve seat bores. Corrective Action: If a valve seat is loose, scored, pitted, defective, or damaged, either replace the cylinder or send the engine cylinder to an authorized vendor to replace the valve seat.	Cylinder 1	
	Cylinder 2	
	Cylinder 3	
	Cylinder 4	
	Cylinder 5	
	Cylinder 6	
Examine intake and exhaust valve guides for looseness, cracks or scoring. Corrective Action: If any valve guide is loose, scored, pitted, defective, or damaged, either replace the cylinder or send the engine cylinder to an authorized vendor to replace the valve guide.	Cylinder 1	
	Cylinder 2	
	Cylinder 3	
	Cylinder 4	
	Cylinder 5	
	Cylinder 6	

Cylinder Assembly Inspection Checklist for TEO-540-A1A Engine Models (Cont.)		
Item to Examine and Corrective Action	Cylinder No.	Findings / Corrective Action
Look for rust/pitting on: <ul style="list-style-type: none"> • Cylinder barrel fins and fin tips in power stroke areas • Cylinder barrel and base flange Corrective Action: Replace the cylinder if rust/pitting is found <u>Do not grind the cylinder bore</u> to remove pitting or damage caused by overheating.	Cylinder 1	
	Cylinder 2	
	Cylinder 3	
	Cylinder 4	
	Cylinder 5	
	Cylinder 6	
Look for discolored/burnt paint or scored cylinder barrel bores. Look for blistered paint on the cylinder barrel. Corrective Action: Replace the cylinder if the cylinder barrel bores are scored or if the paint is discolored/burnt/blistered.	Cylinder 1	
	Cylinder 2	
	Cylinder 3	
	Cylinder 4	
	Cylinder 5	
	Cylinder 6	
Examine the threads in all threaded holes in the cylinder for debris or damage. Corrective Action: Use the correct size bottoming tap to clean the threads. If thread damage cannot be corrected with the tap, replace the cylinder.	Cylinder 1	
	Cylinder 2	
	Cylinder 3	
	Cylinder 4	
	Cylinder 5	
	Cylinder 6	
Examine the intake and exhaust ports for damage, warping, nicks, scoring, or dents. Corrective Action: Replace the cylinder if the intake or exhaust port is damaged, warped, nicked, scored, or dented. <u>Do not grind or repair the intake or exhaust port</u> to correct damage, warping, nicks, scoring, or dents	Cylinder 1	
	Cylinder 2	
	Cylinder 3	
	Cylinder 4	
	Cylinder 5	
	Cylinder 6	

Cylinder Assembly Inspection Checklist for TEO-540-A1A Engine Models (Cont.)		
Item to Examine and Corrective Action	Cylinder No.	Findings / Corrective Action
Look for any radial fin crack extending to the root of a fin. Corrective Action: Replace the cylinder if there is a radial fin crack extending to the root of the fin.	Cylinder 1	
	Cylinder 2	
	Cylinder 3	
	Cylinder 4	
	Cylinder 5	
	Cylinder 6	
Look for broken, bent or straightened, or pitted cylinder head fins. Refer to the “Visual Cylinder Inspection” in this chapter. Corrective Action: Replace any cylinder that has unacceptable cylinder head fins.	Cylinder 1	
	Cylinder 2	
	Cylinder 3	
	Cylinder 4	
	Cylinder 5	
	Cylinder 6	
Look for cracks in the cylinder head. Measure the diameter of the cylinder head at several points to identify any out-of-roundness. Refer to the latest revision of the <i>Service Table of Limits - SSP-1776</i> for measurements. Corrective Action: Replace any cylinder that has a crack in the cylinder head or if the cylinder head is out-of-round.	Cylinder 1	
	Cylinder 2	
	Cylinder 3	
	Cylinder 4	
	Cylinder 5	
	Cylinder 6	
Measure the diameter of the cylinder at right angles from the plane in which the valves are located. Measure the diameter of the cylinder through the plane in which valves are located. Add both diameters and divided this sum by 2 to get the average diameter of the cylinder.	Cylinder 1	Average Cylinder Diameter:
	Cylinder 2	Average Cylinder Diameter:
	Cylinder 3	Average Cylinder Diameter:
	Cylinder 4	Average Cylinder Diameter:
	Cylinder 5	Average Cylinder Diameter:
	Cylinder 6	Average Cylinder Diameter:

Cylinder Assembly Inspection Checklist for TEO-540-A1A Engine Models (Cont.)		
Item to Examine and Corrective Action	Cylinder No.	Findings / Corrective Action
Look for evidence of leakage from the head-to-barrel connection or cracks in the barrel. Corrective Action: Replace any cylinder that has leakage at the cylinder head or barrel or cracks in the barrel.	Cylinder 1	
	Cylinder 2	
	Cylinder 3	
	Cylinder 4	
	Cylinder 5	
	Cylinder 6	
Look for scratches in the honed surface of the cylinder wall or cylinder bore. Corrective Action: Hone the cylinder to remove the scratches. Refer to the latest revision of the <i>Service Table of Limits - SSP 1776</i> for dimensions and limits.	Cylinder 1	
	Cylinder 2	
	Cylinder 3	
	Cylinder 4	
	Cylinder 5	
	Cylinder 6	
Make sure there is not any cylinder head-to-barrel flange movement. Corrective Action: Replace any cylinder that has any cylinder head-to-barrel flange movement.	Cylinder 1	
	Cylinder 2	
	Cylinder 3	
	Cylinder 4	
	Cylinder 5	
	Cylinder 6	

Cylinder Assembly Inspection Checklist for TEO-540-A1A Engine Models (Cont.)		
Item to Examine and Corrective Action	Cylinder No.	Findings / Corrective Action
Examine mounting pads (for intake and exhaust ports) for nicks, scoring or dents. Corrective Action: Replace all nicked, scored, or dented mounting pads for intake and exhaust ports.	Cylinder 1	
	Cylinder 2	
	Cylinder 3	
	Cylinder 4	
	Cylinder 5	
	Cylinder 6	
Examine the sealing surface of the rocker box covers for nicks, scoring or dents that would prevent complete sealing of the rocker box cover. Corrective Action: Replace the cylinder if the mounting pad for the rocker box cover is nicked, scored, or dented or leaking and not sealing correctly.	Cylinder 1	
	Cylinder 2	
	Cylinder 3	
	Cylinder 4	
	Cylinder 5	
	Cylinder 6	
Examine the spark plug Heli-Coil® inserts for looseness or damage. Corrective Action: Replace all loose or damaged spark plug Heli-Coil® inserts with oversize inserts per the “Heli-Coil® Replacement” procedure in this chapter.	Cylinder 1	
	Cylinder 2	
	Cylinder 3	
	Cylinder 4	
	Cylinder 5	
	Cylinder 6	

Cylinder Assembly Inspection Checklist for TEO-540-A1A Engine Models (Cont.)		
Item to Examine and Corrective Action	Cylinder No.	Findings / Corrective Action
Examine studs on the cylinder head for looseness or damage. Corrective Action: Replace all loose or damaged studs with the next higher applicable oversize studs.	Cylinder 1	
	Cylinder 2	
	Cylinder 3	
	Cylinder 4	
	Cylinder 5	
	Cylinder 6	
Measure the inside diameter of the rocker shaft bushings. Refer to the latest revision of the <i>Service Table of Limits - SSP 1776</i> for dimensions. Corrective Action: Replace the rocker shaft bushings if they are not in accordance with specifications.	Cylinder 1	
	Cylinder 2	
	Cylinder 3	
	Cylinder 4	
	Cylinder 5	
	Cylinder 6	

10. Piston Inspection

A. Copy and complete the Piston Inspection Checklist for TEO-540-A1A Engine Models.

Piston Inspection Checklist for TEO-540-A1A Engine Models		
Engine Serial Number: _____ Engine Time: _____		
Date Inspection Done: _____ Inspection done by: _____		
Inspection Item	Findings/Corrective Action	
Examine the entire piston for damage or discoloration from burns. Before cleaning the piston, examine the following areas on the piston for pitting, cavities and surface distortion (which can be an indication of detonation or pre-ignition): <ul style="list-style-type: none"> • Top of the piston • Piston ring lands and grooves • Piston pin holes • Piston pin hole bosses • Look for deposits or damage • Complete the “Piston Cleaning” procedure in Chapter 05-30. <u>NOTICE:</u> Surface distortion can be an indication of detonation or pre-ignition.	Cylinder 1	
	Cylinder 2	
	Cylinder 3	
	Cylinder 4	
	Cylinder 5	
	Cylinder 6	
After Cleaning: <ul style="list-style-type: none"> • Look for cracks on the piston head or skirt. Replace the piston if a crack is found. • Look for bent or broken lands. Replace the piston if the land is broken or bent. • Look for scoring on the piston skirt, damage or discoloration from burns. Replace the piston if scoring, damage or discoloration is found. Identify and correct the cause. • Examine the piston grooves for wear. Replace the piston if high ridges are on the lower lands.* 	Cylinder 1	
	Cylinder 2	
	Cylinder 3	
	Cylinder 4	
	Cylinder 5	
	Cylinder 6	
* High ridges of displaced metal can interfere with operation of new piston rings. The displaced metal can cause excessive piston ring clearance in the valleys.		

Piston Inspection Checklist for TEO-540-A1A Engine Models (Cont.)

NOTICE: Lycoming manufactures pistons with a taper that extends from the top to the bottom of the skirt with the smaller diameter at the top.

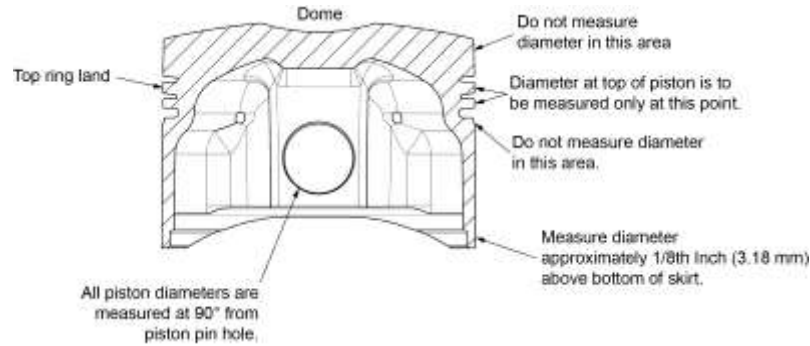


Figure 24
Section Through Piston Showing Points for Measuring Diameter

Inspection Item		Findings/Corrective Action					
		Cylinder 1	Cylinder 2	Cylinder 3	Cylinder 4	Cylinder 5	Cylinder 6
Measure the inside diameter of the piston pin hole (Figure 24).	Actual Measurement**						
	SSP-1776						
Measure the piston diameter at the top ring land of the piston between the top and second compression ring grooves (at a right angle to the piston pin hole) (Figure 24).	Actual Measurement**						
	SSP-1776						
Measure the diameter approximately 1/8 in. (3.18 mm) above the bottom of the piston skirt (at a right angle to the piston pin hole) (Figure 24).	Actual Measurement**						
	SSP-1776						
Subtract the diameter approximately 1/8 in. above the bottom of the piston skirt from the Average Cylinder Diameter (from the Cylinder Assembly Inspection Checklist) and compare to the acceptable clearance in the latest revision of the <i>Service Table of Limits - SSP-1776</i> .							
Piston skirt and cylinder clearance.							
Measure the piston ring clearance.	Actual Measurement**						
	SSP-1776						

**Compare the actual measurement against the limits in the latest revision of the *Service Table of Limits - SSP-1776*. Replace the piston if any of the measurements are out of tolerance.

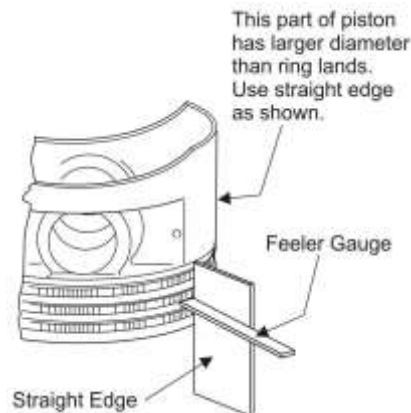
Piston Inspection Checklist for TEO-540-A1A Engine Models (Cont.)


Figure 25
Checking Piston Ring Side Clearance

Inspection Item			Findings/Corrective Action					
			Cylinder 1	Cylinder 2	Cylinder 3	Cylinder 4	Cylinder 5	Cylinder 6
Measure the side clearance between the piston rings and piston with a feeler gauge and straight edge (Figure 25).	Top piston compression ring	Actual Measurement**						
		SSP-1776						
	Second piston compression ring	Actual Measurement**						
		SSP-1776						
	Piston oil ring	Actual Measurement**						
		SSP-1776						
Measure the piston ring gap with feeler gauges. Complete the "Piston Ring End Gap Check" in this chapter.	Top piston compression ring	Actual Measurement**						
		SSP-1776						
	Second piston compression ring	Actual Measurement**						
		SSP-1776						
	Piston oil ring	Actual Measurement**						
		SSP-1776						

**Compare the actual measurement against the limits in the latest revision of the *Service Table of Limits - SSP-1776*. Replace the piston if any of the measurements are out of tolerance.

Piston Inspection Checklist for TEO-540-A1A Engine Models (Cont.)
Comments:

If inspection of the piston shows the original ground surface of the piston skirt to be undamaged, the piston is acceptable and can be re-installed.

If any of the following conditions are found on the piston, replace the piston.

- Damage or pitting, cavities, surface distortion, scoring, or discoloration
- Cracked, bent, or broken lands, scored skirts or any out-of-tolerance dimensional limits
- Piston grooves worn to the extent that high ridges are on the lower lands
- Excessive side clearance of piston rings in grooves

NOTICE: Refer to the *TEO-540-A1A Illustrated Parts Catalog* to identify a replacement piston and associated rings and any new details of piston inspection.

B. Piston Ring End Gap Check:

 **CAUTION** DURING THE PISTON RING END-GAP CHECK, USE CARE NOT TO SCRATCH OR SCORE THE PISTON OR CYLINDER BORE.

- (1) Lubricate the piston ring, piston, and cylinder bore with a light coating of a mixture of 15% pre-lubricant (STP or equivalent) and 85% SAE 50 mineral-base aviation-grade lubricating oil (unless otherwise directed per the latest revision of Service Instruction No. SI-1059).
- (2) Put one of the piston rings in the cylinder in which it will be used.
- (3) To square the piston ring in the cylinder bore, install the piston in the cylinder (per the “Piston Installation” procedure in this chapter) and use a soft mallet to tap the dome end of the piston on the inside, until the bottom of the piston skirt is flush with the end of the cylinder barrel. Remove the piston from the cylinder per the “Piston Removal” procedure in this chapter.
- (4) Measure the piston ring end-gap with feeler gauges. Record the measurement in the Piston Inspection Checklist. Compare the measurement with the ring end gap measurement in the latest revision of the *Service Table of Limits - SSP-1776*.
- (5) If necessary to increase the end-gap, carefully file the ends of the piston ring.
- (6) Repeat this check for each piston ring to be used in each cylinder.

11. Piston Ring Replacement

⚠ CAUTION DO NOT ***UNDER ANY CIRCUMSTANCES*** INSTALL CHROME-PLATED PISTON RINGS IN AN ENGINE HAVING CHROME-PLATED CYLINDER BARRELS. IF YOU ARE UNSURE OF THE CORRECT COMBINATION OF PISTON RINGS TO BE USED, REFER TO THE TEO-540-A1A ILLUSTRATED PARTS CATALOG.

DURING REMOVAL OF THE THREE PISTON RINGS IN THE NEXT STEP, USE CARE NOT TO SCRATCH OR SCORE THE PISTON. REPLACE A SCRATCHED OR SCORED PISTON.

- A. Start from the top down, use the commercially available piston ring expander tool to remove the two top piston compression rings, the piston oil ring, and the inner expander ring (with the piston oil ring) (Figure 26).

NOTICE: New cylinders made by Lycoming Engines will have the correct piston ring finish and do not need further honing. Otherwise, hone the cylinder per the latest revision of Service Instruction No. SI-1047 to ensure correct seating of the new piston rings. For new piston rings, refer to the *TEO-540-A1A Illustrated Parts Catalog* to identify the correct new piston rings to be installed on the piston.

New piston rings are shipped from Lycoming with the piston oil ring and the inner expander ring assembled. The inner expander ring must be separated from the piston oil ring before installing them on the piston.

- B. Apply a generous coating of a mixture of 15% pre-lubricant (STP or equivalent) and 85% SAE 50 mineral-base aviation-grade lubricating oil (unless otherwise directed per the latest revision of Service Instruction No. SI-1059) to the piston rings.
- C. With the piston top side up on a workbench, install the inner expander ring with the part number facing toward the top of the piston in the first groove above the piston pin hole (Figure 26).

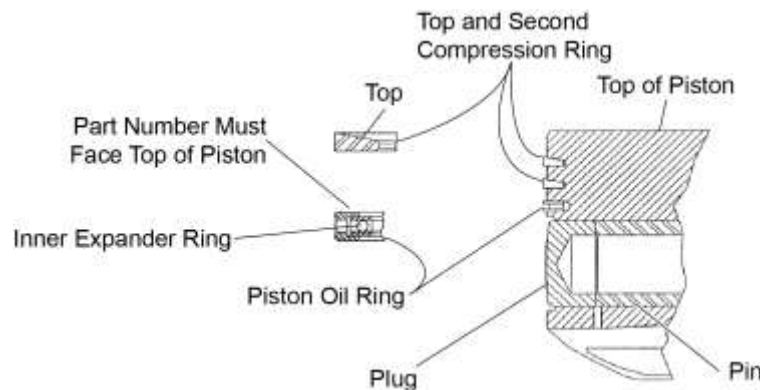


Figure 26
Piston Ring Positions

- D. Assemble the piston oil ring over the inner expander ring with its gap 180° opposite the inner expander ring gap. Orient the gaps in the inner expander ring and piston oil ring perpendicular to the piston pin hole. Compress the assembly several times with the fingers to ensure that the ring lies free and loose in the groove. Both the piston oil ring and the inner expander ring are symmetrical.

- E. Install the two top compression rings (Figure 23) with the word "Top" toward the top of the piston in the remaining top grooves. Orient the gaps in the two compression rings 180° from each other parallel with the piston pin hole.
- F. Compress each of the two top compression piston rings several times with your fingers to make sure the rings are situated freely and loosely in the groove.
- G. To ensure correct installation, measure the side clearance of the rings in the grooves with a feeler gage and a straight edge (Figure 22). If the actual measurement is greater than the maximum allowable side clearance, per the latest revision of the *Service Table of Limits - SSP-1776*, replace the piston.

NOTICE: To ensure correct seating of the piston rings, you must complete the "Break-In/Flight Test/50-Hour Operation" procedure in the "Engine Initiation" chapter of the *TEO-540-A1A Engine Installation and Operation Manual* and per any details in the latest revision of Service Instruction No. SI-1427.

12. Piston Installation

NOTICE: If more than one piston is being installed, make sure you are installing the correct piston in the designated position on the engine.

- A. Clean the pistons as per instructions in the "Piston Cleaning" procedure in Chapter 5-30.
- B. Apply lubricant specified in the latest revision of Service Instruction No. SI-1059 to the inside diameter of the connecting rod bushing, the outer diameter of the piston pin, and the inside diameter of the piston pin hole.

 **CAUTION** DO NOT ATTEMPT TO TURN THE CRANKSHAFT UNLESS THE CONNECTING RODS ARE SUPPORTED.

- C. Turn the crankshaft so that when the Number 1 piston is inserted, it will be at TDC of its firing stroke, with both tappets on the base circle of the camshaft lobes.
- D. Remove the Torque Hold-Down Plates (ST-222), rubber bands, or cylinder base oil seal rings from the crankcase.
- E. Install the piston on the connecting rod where the number stamped on the bottom of the piston head is upright and readable (not upside-down.)
- F. Insert the piston pin into the piston and through the connecting rod (Figure 18) to ensure the entire length of the piston pin is lubricated, move the piston pin back and forth until it is 5centered.

NOTICE: If the original piston pin is tighter than a palm push fit, look for burrs or slight carbon in the pin bore of the piston. Remove any burrs with a stone. Remove carbon deposits as per instructions in Chapter 05-30. If a new piston or piston pin is installed, use a pin that will give a palm push fit at 60° to 70°F (15° to 20°C).

- G. Insert a piston pin plug at each end of the piston pin.
- H. Complete a check of the clearance between the piston and each piston pin plug. Refer to the latest revision of the *Service Table of Limits - SSP-1776* for acceptable clearance limits.
- I. Install the piston rings on the piston per the "Piston Ring Replacement" procedure.
- J. Apply a generous coating of a mixture of 15% pre-lubricant (STP or equivalent) and 85% SAE 50 mineral-base aviation-grade lubricating oil (unless otherwise directed per the latest revision of Service Instruction No. SI-1059) to the piston rings, working the mixture into the ring grooves.
- K. Apply lubricant specified in the latest revision of Service Instruction No. SI-1059 to the piston pin plug faces.

13. Intake Valve Replacement

A. Intake Valve Removal

- (1) Remove the cylinder from the engine per the “Cylinder Removal” procedure in this chapter.
- (2) Remove the intake valve stem cap (Figure 27).

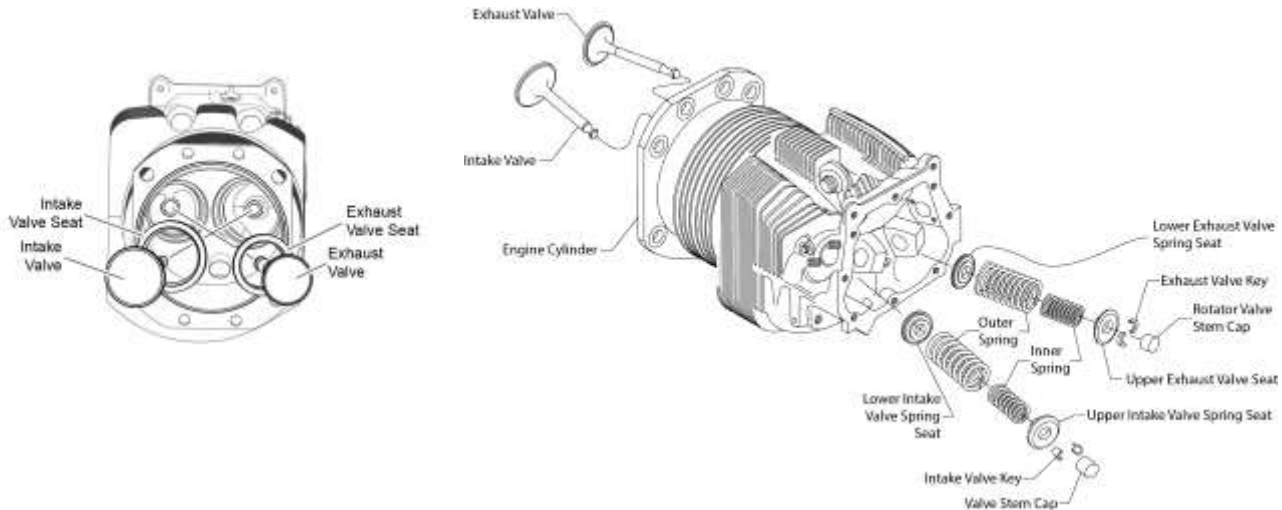


Figure 27
Intake and Exhaust Valves

- (3) Use a Valve Spring Compressor Tool (ST-25) to compress the intake valve spring and remove the valve stem key.
- (4) Remove the valve spring seats and valve springs from the exhaust valve.

NOTICE: Use care not to scratch the inside of the cylinder barrel when removing the intake valve.

- (5) Remove the intake valve from the valve guide, through the cylinder barrel.

B. Intake Valve Installation

NOTICE: Use care not to scratch the inside of the cylinder barrel when installing the intake valve.

- (1) Apply lubricant identified in the latest revision of Service Instruction No. SI-1059 to the intake valve stem.
- (2) Install a serviceable intake valve in the valve guide (Figure 27), through the cylinder barrel.
- (3) Install the valve spring seats and valve springs,
- (4) Use a Valve Spring Compressor Tool (ST-25) to compress the intake valve spring and install the valve stem key.
- (5) Install the intake valve stem cap on the intake valve.
- (6) Install the cylinder on the engine per the “Cylinder Installation” procedure in this chapter.

14. Exhaust Valve Replacement

A. Exhaust Valve Removal

- (1) Remove the cylinder from the engine per the “Cylinder Removal” procedure in this chapter.
- (2) Remove the rotator valve stem cap (Figure 27).
- (3) Use a Valve Spring Compressor Tool (ST-25) to compress the exhaust valve spring and remove the valve stem key.
- (4) Remove the valve spring seats and valve springs from the exhaust valve.

NOTICE: Use care not to scratch the inside of the cylinder barrel when removing the exhaust valve.

- (5) Remove the exhaust valve from the valve guide, through the cylinder barrel.

B. Exhaust Valve Installation

NOTICE: Use care not to scratch the inside of the cylinder barrel when installing the exhaust valve.

- (1) Apply lubricant identified in the latest revision of Service Instruction No. SI-1059 to the exhaust valve stem.
- (2) Install a serviceable exhaust valve in the valve guide (Figure 27), through the cylinder barrel.
- (3) Install the valve spring seats and valve springs,
- (4) Use a Valve Spring Compressor Tool (ST-25) to compress the exhaust valve spring and install the valve stem key.
- (5) Install the rotator valve stem cap on the exhaust valve.
- (6) Install the cylinder on the engine per the “Cylinder Installation” procedure in this chapter.

15. Cylinder Installation

NOTICE: If all cylinders are to be installed, install them by their firing order 1-4-5-2-3-6 (Figure 14).

CAUTION INSTALL ONLY THE NEW CYLINDER BASE OIL SEAL RING AROUND THE CYLINDER BASE. DO NOT APPLY ANY SEALANT OR GASKET MATERIAL WHICH COULD DETERIORATE AND CAUSE A REDUCED TORQUE ON THE CYLINDER BASE STUDS.

- A. Apply a light coat of engine oil mixture to a new cylinder base oil seal ring. (Do not re-install a used cylinder base oil seal ring.)
- B. Install a new cylinder base oil ring (Figure 15) around the cylinder base.
- C. Lubricate the inside diameter of the cylinder barrel with engine oil mixture (15% pre-lubricant (STP or equivalent) and 85% SAE No. 50 mineral base aviation grade lubricating oil) to the depth of the piston rings, approximately 2 in. (5 cm).

D. Apply one or a combination of any of the following lubricants to the outer three threads (Figure 28) on all of the crankcase thru-studs and cylinder hold-down studs (Figure 29):

- Parker Thread Lube
- Mixture of 60% SAE 30W engine oil and 40% Parker Thread Lube
- SAE 30W engine oil
- Mixture of 90% SAE 50W engine oil and 10% STP

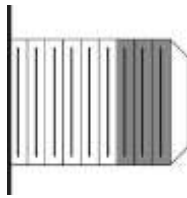


Figure 28
Stud Thread Location
for Lubricant

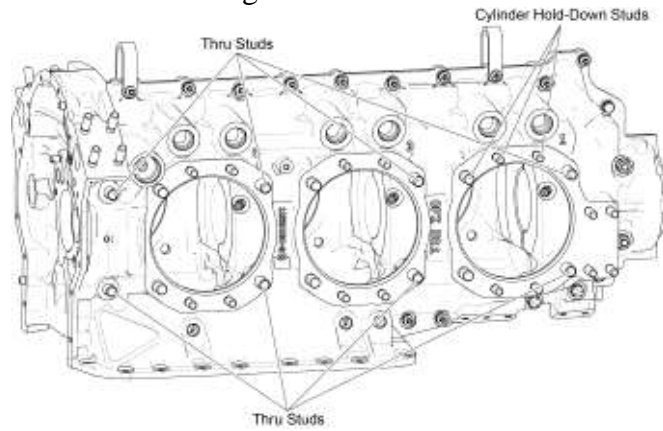


Figure 29
Crankcase Thru-Studs and Cylinder Hold-Down Studs

E. Use the Piston Ring Compressor (ST-485) to install the cylinders (Figure 30) as follows:

- (1) Assemble the Piston Ring Compressor (ST-485) over the top piston rings and install the cylinder over the piston, pushing the piston ring compressor ahead with the cylinder barrel (Figure 31).

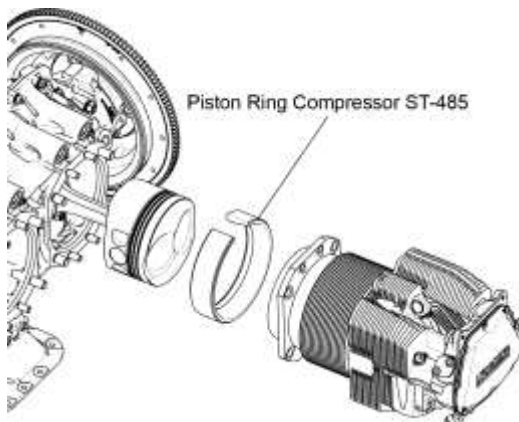


Figure 30
Piston Ring Compressor (ST-485)



Figure 31
Install the Cylinder

- (2) As the cylinder barrel approaches the crankcase, catch the Piston Ring Compressor as it drops off the piston skirt.
- (3) As the cylinder assembly pilot is entering the crankcase, align the cylinder hold-down studs with the holes in the cylinder flange.
- (4) Push the cylinder until the cylinder flange makes contact with the crankcase.
- (5) Install a vented plug in each spark plug hole on the cylinder to prevent the entrance of foreign materials.

- F. Install the cylinder base hold-down nuts (Figures 18 and 32) on the thru-studs and cylinder hold-down studs.

⚠ CAUTION TORQUE THE CYLINDER NUTS IN THE SPECIFIED SEQUENCE IN FIGURE 32.

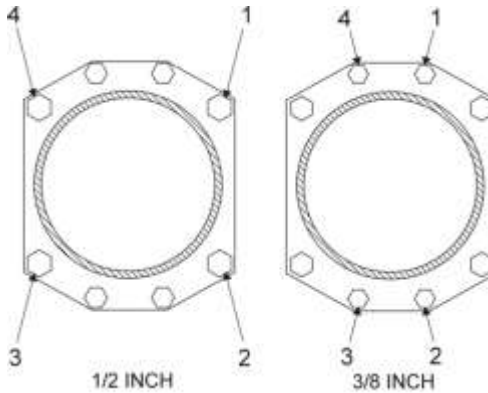


Figure 32
Sequence of Tightening Cylinder Base Nuts

- G. Torque for cylinder base hold-down nuts as follows:
- (1) Torque the 1/2 in. nuts to 25 ft.-lb. (34 Nm) in the sequence shown in Figure 32.
 - (2) Torque the 1/2 in. nuts to 50 ft.-lb. (68 Nm) in the sequence shown in Figure 32.
 - (3) Torque all 3/8 in. nuts to 25 ft.-lb. (34 Nm) in the sequence shown in Figure 32. The torque sequence for these nuts is optional.
 - (4) Use the same sequence shown in Figure 32, complete a torque check to 50 ft.-lb. (68 Nm) for all 1/2-in. nuts on the cylinder base studs.
 - (5) Tighten both ends of the free thru-studs at the same time at the all locations. Make sure all thru-studs have at least 1-1/2 threads above attaching nuts at both ends.
 - (6) Make sure all cylinder base hold-down nuts are torqued. Complete a torque check of all nuts on the cylinder base using the torque wrench to apply the appropriate torque on each nut for 5 seconds. If the nut does not turn, it is correctly torqued.
 - (7) Apply torque seal to all cylinder hold-down nuts where the nut contacts the barrel.

⚠ CAUTION: MAKE SURE ALL CYLINDER FASTENERS ON THE CRANKCASE ARE TORQUED CORRECTLY AND NONE ARE LOOSE.

H. Shroud Tube Installation

⚠ CAUTION BE SURE THERE IS NO OIL INSIDE THE TAPPET BODIES AND THAT THE PLUNGER ASSEMBLY AND CYLINDER ASSEMBLY ARE THOROUGHLY CLEAN AND DRY. WASH ANY LUBRICATING OR PRESERVATIVE OIL (MINERAL SPIRITS, STODDARD SOLUTION, OR EQUIVALENT) FROM THESE PARTS, SINCE PLUNGER ASSEMBLIES MUST BE COMPLETELY DRY FOR THE TAPPET CLEARANCE CHECK.

NOTICE: Install the shroud tube oil seals in the crankcase first.

One shroud tube (Figure 18) installs on the exhaust port of the cylinder and another shroud tube installs on the intake port.

- (1) For each of the two shroud tubes, install the plunger assembly and hydraulic socket in the tappet body in the crankcase (Figure 33).
- (2) Apply engine oil mixture (15% pre-lubricant (STP or equivalent) and 85% SAE No. 50 mineral base aviation grade lubricating oil) to all four of the shroud tube oil seals, two for each shroud tube.
- (3) Install one shroud tube oil seal and a washer into the cups in the tappet bores of the crankcase (Figure 34).
- (4) On each shroud tube, assemble the other shroud tube oil seal and sleeve over the outer end of the shroud tube (Figure 18).
- (5) Install the shroud tube spring and washer over the inner ends of each shroud tube where the detent notches in the spring are 90° removed from the tangs on the shroud tubes as shown in Figure 35.
- (6) Install each shroud tube through the shroud tube oil seal in the crankcase.
- (7) Hold both shroud tubes with the detent at the inner end at the unlocked position and insert the outer end of the tubes in the rocker box of the cylinder head.
- (8) Make sure that all shroud tube oil seals are installed squarely.
- (9) Turn each shroud tube 90° and use either a Shroud Tube Wrench, ST-142 (Figure 36) or an internal pipe wrench to engage the tangs with the detents in the springs to lock each shroud tube in position.
- (10) As necessary, gently tap the shroud tube springs with a rubber mallet to correctly and securely seat these springs (Figure 37).

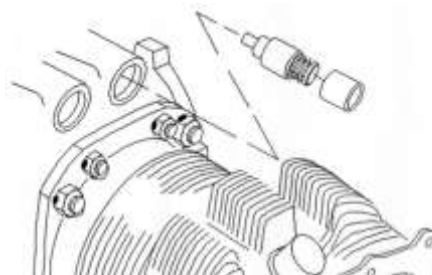


Figure 33
Tappet Plunger and Socket



Figure 34
Shroud Tube Oil Seals in Crankcase



Figure 35
Shroud Tube with Springs and Washer



Figure 36
Shroud Tube Wrench ST-142



Figure 37
Correctly Aligned Shroud Tube Springs

I. Push Rod Installation

- (1) Turn the crankshaft to position the piston at top dead center of the compression stroke on the applicable cylinder to ensure that the valves are closed.
- (2) Use a brush and apply a mixture of 15% STP or equivalent and 85% SAE No. 50 mineral-based aviation-grade lubricating oil to 1 inch of both ends of the push rods. Refer to the latest revision of Service Instruction No. SI-1059 for any new details.
- (3) Install the push rods into the full length of the shroud tube.
- (4) Press the push rods tightly from the outer end of the shroud tube to test the spring tension and free travel of the unloaded or dry hydraulic tappet plungers. Make sure the springs compress and return.

J. Install the valve stem cap over the exhaust valve stem (Figure 27).

⚠ CAUTION SOME LYCOMING ENGINES USE A DIFFERENT ROCKER ARM FOR EACH INTAKE AND EXHAUST VALVE. MAKE SURE THE INTAKE VALVE ROCKER ASSEMBLIES ARE INSTALLED ON THE INTAKE SIDE OF THE CYLINDER. MAKE SURE THE EXHAUST VALVE ROCKER ASSEMBLY IS INSTALLED ON THE EXHAUST VALVE SIDE OF THE CYLINDER.

K. Install the rockers with the cupped end on the push rod (Figure 18).**L. Align each valve rocker assembly with the rocker shaft.****M. Slide the valve rocker shafts through each valve rocker assembly and washer to seat the valve rocker in place for both the intake and exhaust valves.****N. Make sure the valve rocker assemblies are in the correct position on the intake and exhaust valves.**

⚠ CAUTION BE SURE THERE IS NO OIL INSIDE THE TAPPET BODIES AND THAT THE TAPPET PLUNGER AND CYLINDER ASSEMBLY ARE THOROUGHLY CLEAN AND DRY. WASH ANY LUBRICATING OR PRESERVATIVE OIL (MINERAL SPIRITS, STODDARD SOLUTION, OR EQUIVALENT) FROM THESE PARTS PER THE "TAPPET CLEANING" SECTION IN CHAPTER 05-30, SINCE TAPPET ASSEMBLIES MUST BE ABSOLUTELY DRY FOR THE TAPPET CLEARANCE CHECK.

NOTICE: If the clearance between the valve rocker and the cylinder head cannot be brought within the *Service Table of Limits - SSP-1776* install the standard valve rocker thrust washer per the latest revision of Service Bulletin No. SB 225 for replacement valve rocker thrust washers.

O. Measure the clearance between the valve rocker and cylinder head. Refer to the latest revision of the *Service Table of Limits - SSP-1776*.

NOTICE: The procedure to measure dry tappet clearance is the same for intake or exhaust valves.

P. To measure the dry tappet clearance:

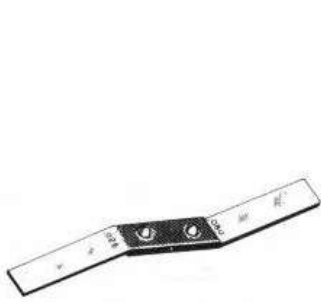


Figure 38
Valve Clearance Gage
(ST-23)

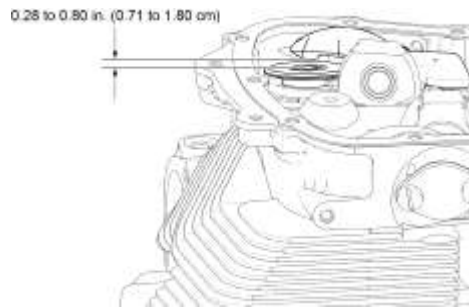


Figure 39
Dry Tappet Clearance

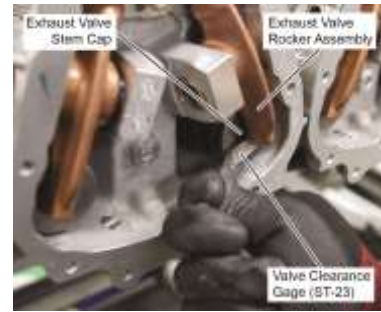


Figure 40
Measuring Dry Tappet
Clearance

- (1) Push in on the push rod end of the valve rocker.
- (2) Use a Valve Clearance Gage (ST-23) (Figure 38) to measure the distance between the end of the valve rocker assembly and the valve stem cap (Figures 39 and 40).
 - (a) Insert the 0.028 end of the Valve Clearance Gage (ST-23) between the valve rocker assembly and the valve stem cap. If it cannot be inserted, remove the current push rod and use a shorter pushrod.
 - (b) Try to insert the 0.080 end of the Valve Clearance Gage (ST-23) between the valve rocker assembly and the valve stem cap. If it can be inserted, remove the current push rod and use a longer pushrod.
- (3) The distance must be between 0.028 and 0.080 in. (0.711 to 2.032 mm).

NOTICE: If the clearance is not within the prescribed limit, insert a longer or shorter push rod to obtain the correct clearance. Refer to the *TEO-540-A1A Illustrated Parts Catalog* for push rod information.

Q. Recheck the valve rocker clearance on all cylinders and make any adjustments as required.

R. Lubricate rocker contact surfaces (Figure 41) with Modoc[®] Oil 175.



Figure 41
Valve Rocker Lubrication

NOTICE: If cork a gasket was used, install a new cork gasket in the next step. A silicone gasket can be re-installed if it is intact and not deformed or damaged.

- S. Install a new rocker box cover gasket (Figure 18) and cover with screws on each rocker box. Torque the screws to 50 in.-lb. (5.6 Nm).
- T. Remove the vented plug from each spark plug hole.
- U. Install the top and bottom spark plugs per the section “Spark Plug Installation” in Chapter 74-20.
- V. Install the applicable intake pipe (Figure 11) on the cylinder per the “Intake Pipe Installation” procedure in Chapter 72-80.
- W. Install the Knock Sensor (Figure 16) and Cylinder Head Temperature Sensor (Figure 17) on the engine cylinder and connect the wiring harness to the sensors. Refer to the "Sensor Replacement Procedures" in Chapter 72-70.

NOTICE: After replacing one or more cylinder, you must complete the “Break-In/Flight Test/50-Hour Operation” procedure the “Engine Initiation” chapter of the *TEO-540-A1A Engine Installation and Operation Manual* and per any details in the latest revision of Service Instruction No. SI-1427.

X. Intercylinder Baffle Installation

- (1) Engage the "S-Type" retaining hook (Figure 3) through the hole in the in the intercylinder baffle.
- (2) Put the baffle in position beneath and between the cylinders on the bottom of the engine as shown in Figure 42 and turn the hook up between the cylinder barrels.



Figure 42
Placement of Intercylinder Baffle
on Down Exhaust Engines



Figure 43
Intercylinder Baffle Installed on Three Fins

- (3) Put a baffle retainer in place between the cylinders and use a cotter pin puller to pull the retainer hook through the slot in the retainer. The retainer is forced down until the hook comes above the surface of the retainer far enough to be engaged over the bridge between the slots in the retainer.

- (4) Ensure the intercyylinder baffles are installed on three fins as shown in Figure 43 as a “tight fit” (as shown in Figure 44) and not loose (Figure 45). It could be necessary to bend the angles of the intercyylinder baffle to ensure a tight fit.



Figure 44
Correct Tight Fit of Intercylinder Baffle



Figure 45
Loose Fit of Intercylinder Baffle

- Y. Install the fuel injector rail assembly on the cylinder per the “Fuel Injector Rail Assembly Installation” procedure in Chapter 73-10.
- Z. Install the exhaust tube (Figure 11) and a new gasket with the two washers and two nuts.
- AA. Install the applicable intake pipe on the cylinder per the “Intake Pipe Installation” procedure in Chapter 72-80.
- AB. Oil Drain Tube Installation

NOTICE: Since there are different oil drain tube assemblies for the engine cylinders, refer to the *TEO-540-A1A Illustrated Parts Catalog* for the correct part number for the oil drain tube assembly to ensure the correct oil drain tube assembly is installed on the corresponding engine cylinder.

- (1) If a new nipple (Figure 46) is to be installed on the crankcase, apply Loctite[®] 564 to the threads of the nipple. Torque the nipple to 85 in.-lb. (9.6 Nm).
- (2) Connect a new hose to the nipple in the crankcase.

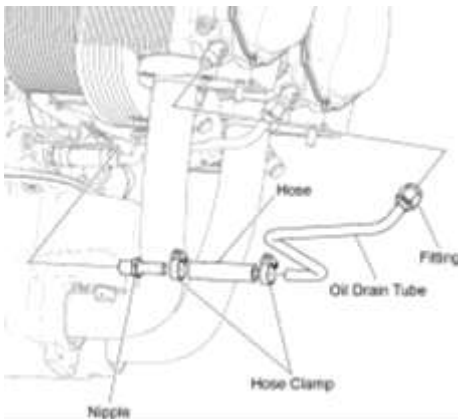


Figure 46
Oil Drain Tube



Figure 47
Oil Drain Tubes, Clamps, and Fittings

- (3) Install and tighten a hose clamp on the hose as follows: for Cylinder Nos. 1 and 2, face towards the front of the engine; for the remaining cylinders, install the hose clamp face towards the rear of the engine (Figure 47).
- (4) Connect the oil drain tube to the elbow fitting at the cylinder with a flange nut. Torque the nut per instructions in the latest revision of the *Service Table of Limits - SSP-1776*.
- (5) Connect the oil drain tube to the installed new hose and install a hose clamp.
- (6) Torque both hose clamps per instructions in the latest revision of the *Service Table of Limits - SSP-1776*
- (7) Tighten the drain tube coupling to the fitting finger tight, plus $\frac{1}{2}$ to $\frac{3}{4}$ turn. Adjust the cylinder head drain fitting as necessary for alignment. Make sure the oil drain tubes are not touching the intercylinder baffles or cylinders.

16. Corrective Action for Valve Sticking

NOTICE: If valve sticking is a problem, complete the 1000-hour inspection (regardless of the number of engine operating hours). After correcting the cause of valve sticking, complete the 1000-hour inspection after the next 1000 hours of engine operation, unless valve sticking occurs again.

Sticking between the valve stem and guide (on intake and exhaust valves) can substantially change valve opening and closing. If the valve cannot open or close correctly, incomplete combustion will occur, which can cause formation of more deposits and increased valve sticking. Because a correctly-timed sequence of valve opening and closing is essential to efficient and reliable engine operation, the cause of valve sticking must be identified and corrected.

 **WARNING** A STUCK VALVE CAN CAUSE ENGINE FAILURE.

NOTICE: If one valve is sticking, examine all other valves on all of the engine cylinders as a precaution.

- A. Per Chapter 12-10 complete an oil and filter change and have an analysis done on the metallic solids in the oil filter to identify the contamination and find the source to correct the problem. Refer to the latest revision of Service Bulletin No. SB-480.
- B. If the source of the oil contamination cannot be found or corrected, complete the following procedures in Chapter 12-10:
 - (1) Replace the oil filter (more often) after every 25 hours of operation (instead of after every 50 hours of engine operation.)
 - (2) Complete an oil change after every 25 hours of operation (instead of after every 50 hours of engine operation.)
- C. Complete an air filter change at more frequent intervals and apply a cover over the induction system to keep dirt out of the oil supply.
- D. Examine the cooling air baffles and baffle strips for contamination. Remove any contamination.

- E. Identify with a tag and remove the top spark plugs from the engine cylinders per the “Spark Plug Removal” procedure in Chapter 74-20.
- F. Identify the location of each cylinder and valve train component for reference on assembly and remove the cylinder and valve train components per the “Cylinder Removal” section in this chapter.
- G. Remove the intake and exhaust valves per the “Intake Valve Removal” and “Exhaust Valve Removal” sections in this chapter.
- H. Examine the valve stem keys (Figure 27) for wear. Look for any distinct, uniform patterns. Replace worn valve stem keys.

NOTICE: Refer to the latest revision of the *Service Table of Limits - SSP-1776* for valve guide dimensions to use the correct reamer.

Use reamer tools to remove hardened carbon from the valve guides.

- I. Apply ordinary cup grease on the flutes of the reamer to trap and hold the deposits on the reamer.
- J. Ream the valve guide as follows:
 - (1) Apply force on the reamer to ensure the reamer has gone through the full length of the valve guide. The 1 in. (2.54 cm) pilot must be visible through the exhaust port or through spark plug hole using an angled mirror.
 - (2) Clean the valve guide per the “Hard Carbon Removal” procedure in Chapter 05-30 for additional cleaning details.
 - (3) Measure the inner diameter of the valve guide using the correct plug gage.
 - (4) Examine the reamed hole to see if the reamer has cut all the way to the exhaust port end of the guide. If it has not, and the exhaust port end of the hole looks dark, the valve guide is bell-mouthed and must be replaced.
 - (5) If the valve is acceptable, apply lubricant to the valve guide.

 **CAUTION** NEVER USE THE PISTON TO PUSH THE VALVE THROUGH THE GUIDE.

- K. Install the valves that are satisfactory, in the same position where they were. Refer to the “Intake Valve Installation” and “Exhaust Valve Installation” procedures in this chapter.
- L. Install the valve springs and valve spring seats.
- M. Remove and clean the hydraulic lifter and remove all oil. Refer to the “Tappet Cleaning” procedure in Chapter 05-30.
- N. Examine the lifter for any malfunction.
- O. Clean the inner diameter of the cam follower.
- P. Install the hydraulic lifter.
- Q. Install the cylinder and valve train components in the same position as removed. Refer to the “Cylinder Installation” procedure in this chapter.
- R. Examine, rotate (as needed), and install serviceable spark plugs per the “Spark Plug Inspection,” “Spark Plug Rotation,” and “Spark Plug Installation” procedures in Chapter 74-20.

17. Intake and Exhaust Valve Guide Replacement

Any time a valve guide is to be replaced, send the engine cylinder to an authorized vendor who can complete this replacement.

18. Intake and Exhaust Valve Seat Replacement

If an intake or exhaust valve seat (Figure 48) is damaged or must be replaced, send the engine cylinder to an authorized vendor who can complete this replacement.

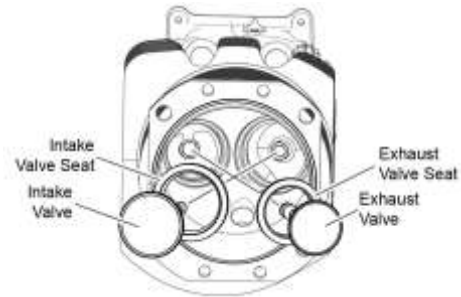


Figure 48
Intake and Exhaust Valve Seats

19. Barrel Glaze and Varnish Removal from Interior Cylinder Barrel

- A. Use a self-centering, self-bottoming hone that follows the choke located in the top of the cylinder barrel.
- B. Use kerosene or light engine oil for lubrication while honing.
- C. Put the deglazing hone in a low-speed drill.
- D. Surface hone each cylinder barrel with a minimum of six to eight passes over the glazed surface, using a smooth up and down motion of the hone to achieve a good cross-hatch pattern on the cylinder barrel wall.
- E. Thoroughly clean the hone.
- F. Wipe as much of the abrasive build-up from the cylinder walls and recesses as possible, especially the recesses formed by the top of the cylinder barrel and the bottom of the cylinder head.
- G. Make a hooked tool from soft wire and rub the tool back and forth in the recess to loosen any built-up abrasive. Complete this task each time the cylinder is flushed. There must not be any abraded material in this area.
- H. Complete the “Cylinder Cleaning” procedure in Chapter 05-30.
- I. Lubricate the internal cylinder barrel thoroughly with SAE 50 engine oil or a rust preventative oil that conforms with MIL-C-6529.

NOTICE: If step wear is found inside the cylinder barrel, measure it using the dial bore gage (which is usually used to measure cylinder diameter). If the depth of the step wear is less than 0.0025 in. (0.0635 mm), remove the step as per the previous steps to remove cylinder barrel glaze. If the barrel contains a wear step exceeding 0.0025 in. (0.0635 mm), replace the cylinder. Record the condition and corrective action in the engine logbook.

In some cylinders, a small rough area can be found at either end of the barrel extending less than 0.250 in. (6.35 mm) from the end. This condition is a result of the manufacturing process and has no effect on the quality or condition of the barrel.

20. Heli-Coil® Replacement

- A. Replace the spark plug Heli-Coil® insert (Figure 49) in the cylinder head if the threads in the spark plug hole in the cylinder are damaged (usually occurs when hard carbon on the end of the spark plug causes the insert to unwind during spark plug removal).

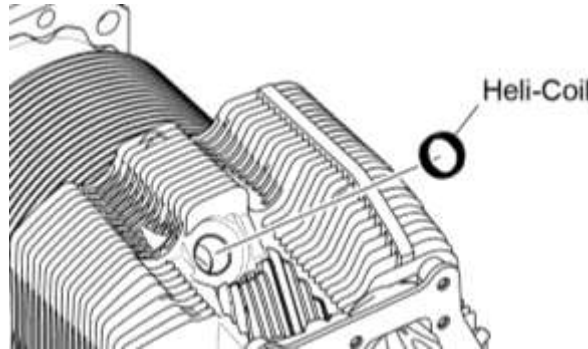


Figure 49
Heli-Coils®

NOTICE: Always install a larger oversized 0.010 in. (0.254 mm) Heli-Coil® insert in the spark plug hole on the cylinder head to replace a standard sized Heli-Coil® insert. Never replace a standard sized Heli-Coil® insert with another standard sized Heli-Coil® insert. The oversize Heli-Coil® inserts are identified by three marks on the tang of the Heli-Coil® insert as shown Figure 50.

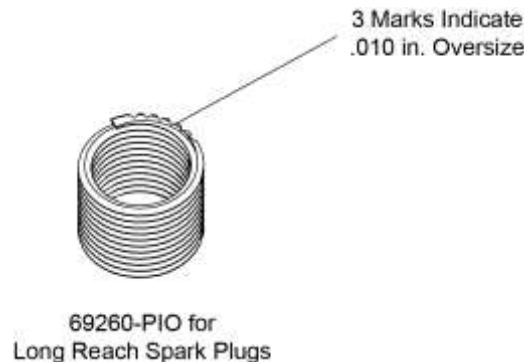


Figure 50
Heli-Coil® Inserts for Long Reach Spark Plugs

- (1) Disable all power to the engine to prevent propeller rotation and engine start. Disconnect ignition leads from all spark plugs.
- (2) If not already done, remove the Heli-Coil® insert from the spark plug hole as follows:
 - (a) Insert the T-shaped Removing Tool P/N 64595 (Figure 51) in the spark plug hole. Press the tool down firmly for the edge of the tool to cut into the top thread of the insert.
 - (b) Turn the tool counterclockwise to remove the insert.

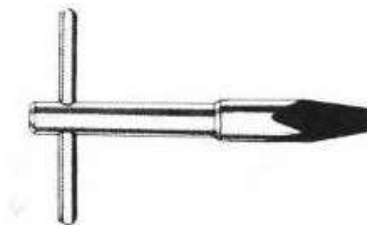


Figure 51
Removing Tool P/N 64595

- (3) Record the size of the removed Heli-Coil® insert in the engine logbook and then discard the insert.
 - (4) Apply a coat of grease liberally to the Bottoming Tap 64596-1 (Figure 52).
 - (5) If the Heli-Coil® insert is replaced while the cylinder is installed on the engine, take precautions to prevent metal shavings from falling into the combustion chamber.
- ⚠ CAUTION** IF METAL SHAVINGS FALL INTO THE COMBUSTION CHAMBER OF THE CYLINDER. STOP AND REMOVE ALL SHAVINGS AND DEBRIS. THE COMBUSTION CHAMBER MUST BE CLEAN.
- (6) Turn the crankshaft to the start of the compression stroke.
 - (7) Put 8 ft. (2.4 m) of 3/8 in. (9.5 mm) nylon rope through the opposite spark plug hole.
 - (8) Turn the crankshaft to force the rope against the bottom of the spark plug hole that is to be tapped.
 - (9) Use the 0.010 in. oversized Bottoming Tap 64596-1 (Figure 52), to tap an oversize hole for the new 0.010 in. oversized Heli-Coil® insert.
 - (10) Remove all chips and shavings to prevent contamination from foreign object debris.
 - (11) Remove the rope from the spark plug hole.



Figure 52
0.010-Inch Bottoming Tap 64596-1



Figure 53
Inserting Tool P/N 64594

- (12) Install the new 0.010 in. oversized Heli-Coil® insert into the spark plug hole as follows:
 - (a) Use the T-shaped Inserting Tool P/N 64594 (Figure 53) and withdraw the mandrel portion of this tool beyond the recessed section of its sleeve.
 - (b) Put the new 0.010 in. oversized Heli-Coil® insert into the recess on the tool.
 - (c) Push the mandrel to engage its slotted end with the tang of the new 0.010 in. oversized Heli-Coil® insert.
 - (d) Turn the mandrel clockwise and press it forward slightly to engage the threaded end of the new 0.010 in. oversized Heli-Coil® insert.
 - (e) While holding the sleeve of the tool, turn the mandrel where adjacent turns of the new 0.010 in. oversized Heli-Coil® insert are in contact with each other to prevent crossed threads and the insert is firmly on the Inserting Tool P/N 64594. Keep the new 0.010 in. oversized Heli-Coil® insert securely on the tool to enable installation of the insert on the threads of the cylinder head.

- (f) Turn the threaded portion of the sleeve on the tool within a half-turn from the end of the coil on the new 0.010 in. oversized Heli-Coil® insert.
- (g) Use the Inserting Tool P/N 64594 (Figure 53) to install the new 0.010 in. oversized Heli-Coil® insert into the spark plug hole on the cylinder head. Be sure that the first coil engages with the first thread.
- (h) Continue to turn the Inserting Tool P/N 64594. As the face of the sleeve on the tool is 1/16-inch away from the face of the boss, be sure to hold the Inserting Tool P/N 64594 tightly with one hand. Use your other hand to simultaneously turn the sleeve counter-clockwise to free the left half-turn of the new insert.
- (i) Slide the sleeve toward the top of the mandrel. The new 0.010 in. oversized Heli-Coil® insert is installed correctly at this point if the end of the insert is visible projecting above the boss.
- (j) Continue to turn the mandrel clockwise until the insert is no longer visible above the boss.
- (k) When the top of the insert is approximately a half turn from the face of the boss, remove the Inserting Tool P/N 64594.
- (l) Use the Expanding and Staking Tool P/N 64593 (Figure 54) to stake the new installed 0.010 in. oversized Heli-Coil® insert securely in the spark plug hole as follows:
 - 1 Fix the stop nut/adjusting screw on the Expanding and Staking Tool P/N 64593 to limit expansion of the mandrel to within the thread gage.

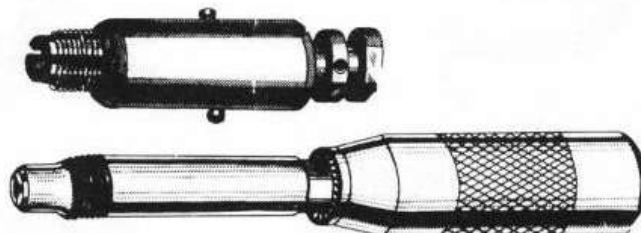


Figure 54
Expanding and Staking Tool P/N 64593

- 2 Assemble the staking sleeve of the Expanding and Staking Tool P/N 64593 over the mandrel until the sleeve meets the boss.
 - 3 Gently tap the top of the staking sleeve with a plastic mallet to make a slight chamfered edge around the periphery of the tapped hole.
 - 4 Remove the adjusting screw/stop nut on the Expanding and Staking Tool P/N 64593 and remove this tool and its expanding mandrel
 - 5 Use needle-nose pliers to break off the tang at the notch of the newly installed 0.010 in. oversized Heli-Coil® insert.
- (13) Record replacement in the engine logbook of the standard sized Heli-Coil® insert with a new oversized Heli-Coil® insert for the applicable cylinder number.

72-40 - TURBOCHARGER MAINTENANCE

1. General

- A. This engine has two turbochargers, one on each side. A left and right exhaust transition attaches to a respective left and right turbocharger (Figure 1). Each turbocharger has two sides, a turbine side and a compressor side. Exhaust gas continuously passes through the turbine side of the turbocharger and turns the turbine within the turbocharger. The turbine rotation compresses air that flows through intake pipes on the compressor side of the turbocharger. The air becomes pressurized and is discharged to left and right intercoolers through pipes. From the intercooler, this cooler air flow passes through a respective left and right intake pipe to the air inlet housing (Figure 2). Through the throttle body and into the sump air intake then through the intake pipes to the cylinders. The exhaust gas is discharged through exhaust outlet pipes attached to the turbocharger.
- B. An exhaust bypass valve (Figure 1) at the Y-shaped exhaust transition on the left side of the engine controls the amount of exhaust gas flow to the turbocharger. This valve is controlled by an oil pressure actuator which is activated by an ECU controlled solenoid in the accessory housing
- C. The EECS controls the amount of exhaust gases supplied to the turbine wheels and monitors compressor outlet pressure from sea level to critical altitude.

2. 50-Hour Turbocharger Inspection

- A. Examine all of the hoses and mounting brackets in the turbocharger system for damage, leaks, tightness, and blockage. Identify and correct the cause of any leaks. Replace any damaged gaskets or hoses.
- B. Make sure all connections in the exhaust system at the turbocharger V-band couplings (Figure 1) are tight and do not have air leaks. Examine the tightness of the V-band coupling on the turbocharger by inserting a screwdriver in the space made by the hinged latch of the coupling. Try to turn the coupling using a force of approximately 20 ft.-lb. (27 Nm). If the clamp does not turn, measure the torque of the self-locking clamp nut by tightening it to the torque in the Special Torque Requirements Tables in Part 1, Section V in the latest revision of the *Service Table of Limits - SSP-1776*. If the clamp turns, remove it, clean it, and examine it for cracks or distortions. Re-use or replace the clamp as necessary.

Before installing the V-band coupling on the engine, carefully clean the coupling area of the exhaust transition and mating flange on the turbine side of the turbocharger.
- C. Repeat the previous step for the V-band couplings that attach the exhaust bypass valve (Figure 1).
- D. Examine all flexible hoses in the induction system for brittleness which can be evidence of wear. Replace worn hoses. Make sure all connections in the induction system are tight and do not have any leaks (Figure 2).
- E. Examine the wastegate linkage for freedom of movement. Lubricate the shaft and linkage.
- F. Look for dirt or carbon build-up on the outside of the turbocharger. Remove the build-up per the turbocharger manufacturer's instructions. Identify and correct the cause.
- G. Record all findings and any corrective action in the engine logbook and on the 50-Hour Inspection Checklist.

3. 100-Hour Turbocharger Inspection

- A. Complete the “50-Hour Turbocharger Inspection” in this chapter.
- B. Examine the turbochargers. Look for nicked or bent turbine blades and any damage from objects. If any turbine blade is nicked, bent, or damaged, replace the turbocharger.
- C. Examine all of the air ducts and connections for leaks. Look for leaks at the manifold connections to the turbine inlet and at the exhaust manifold gasket. Identify and correct the cause of any leaks.
- D. Replace any leaky gaskets. Two gaskets are necessary at the exhaust port.

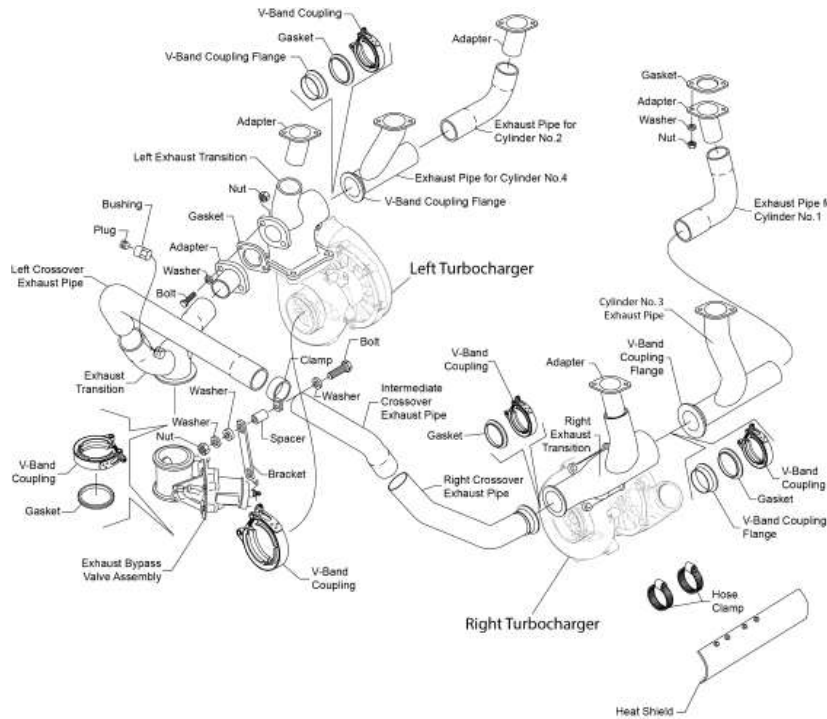


Figure 1
Exhaust Crossover Pipes and Transition Assembly

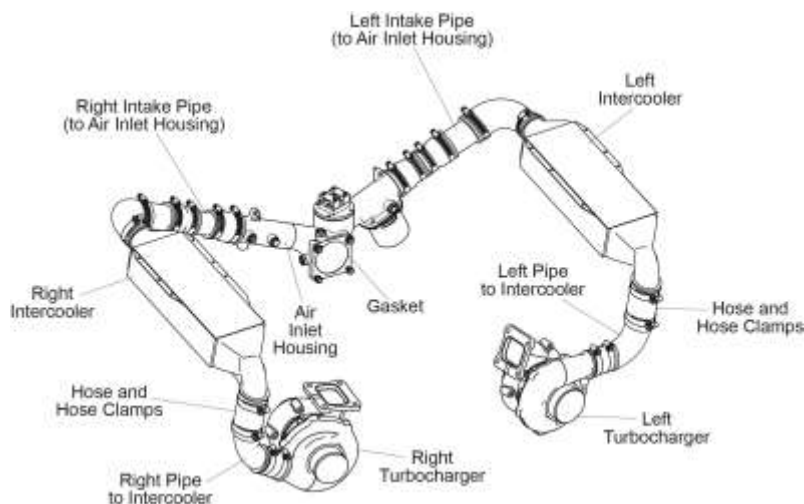


Figure 2
Compressor-to-Intercooler Connection

- E. Make sure the torque on the mounting bolts that attach turbine side of the turbocharger and transition assembly to the mounting bracket agree with the Standard Torque Tables in the latest revision of the *Service Table of Limits - SSP-1776*.

NOTICE: The clearance at the turbine blade tip, measured as shown in Figure 3, identifies the general condition of the turbocharger.

- F. Remove the exhaust pipe from the turbine discharge port and measure the clearance between the turbine blades and housing.
- G. Use a feeler gage to measure the space between the impeller blades and the turbine housing at intervals of 90° as shown in Figure 3.

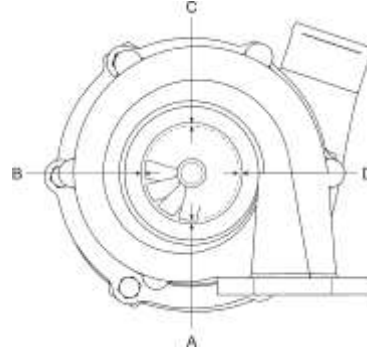


Figure 3
Discharge Port of Turbine Showing
Locations for Clearance Measurements

NOTICE: In the next step, do not insert the feeler gage more than 0.050 in. (1.270 mm).

For example: $A + B + C + D = 0.064 + 0.120 + 0.053 + 0.081 = 0.318 / 4 = 0.0795$ in. (2.032 mm)

- H. Measure the maximum clearance between the housing and the blade tips in the four locations. If the maximum clearance exceeds 0.120 in. (3.048 mm) at any point, replace the turbocharger. Refer to the sections "Turbocharger Removal" and "Turbocharger Installation" in this chapter.
4. 250-Hour Turbocharger Inspection
- A. Complete the "50-Hour Turbocharger Inspection" in this chapter.
- B. Remove the turbocharger as per instructions in the section "Turbocharger Removal" in this chapter.
- C. Examine the turbocharger. Look for nicked or bent turbine blades and any damage from objects. If any turbine blade is nicked, bent, or damaged, replace the turbocharger.
- D. Look for dirt and carbon build-up and uneven deposits on the turbine wheel. Remove any build-up per the turbocharger manufacturer's instructions. Identify and correct the cause.
- E. Examine the turbine wheels for Foreign Object Damage (FOD).
- F. Turn the turbine wheel and make sure that it turns freely in the turbocharger. If the turbine wheel does not turn freely, replace the turbocharger.
- G. Examine the inside surface of the turbine housing for shiny areas on the rough exhaust system deposits. Shiny areas are evidence that the wheel has come in contact with deposits. Look for deposits in the turbine. Remove the deposits per the turbocharger manufacturer's instructions, identify and correct the cause.
- H. Install the turbocharger as per instructions in the "Turbocharger Installation" section in this chapter.

5. Turbocharger Removal

⚠ CAUTION PRIOR TO TURBOCHARGER REMOVAL, LET THE ENGINE AND THE EXHAUST SYSTEM COOL FOR 1 HOUR OR LONGER AFTER ENGINE SHUTDOWN TO PREVENT BURNS. ENSURE THAT THE BATTERY IS DISCONNECTED TO PREVENT ENGINE START.

NOTICE: This procedure applies to removal of either turbocharger.

A. If there is enough clearance, complete this procedure with the engine installed. Otherwise, remove the engine from the aircraft per instructions in Chapter 72-00.

B. Remove the engine cowling.

⚠ CAUTION DO NOT USE ETCH TOOLS, GRAPHITE LEAD PENCIL, OR SCRIBE TO MARK EXHAUST PIPES. FOR BEST RESULTS, USE A NONGRAPHITE MARKER SUCH AS COLORBRITE NOS. 2127, 4127, OR MARKS-A-LOT.

C. Apply labels to identify the turbocharger and attached exhaust pipes and pieces for reference on assembly.

D. Take photos or draw a sketch of the exhaust system as installed and attached to the turbocharger or refer to Figure 1. Identify the locations of V-band couplings, clamps, and adapters with temporary labels.

E. Remove the V-band coupling from each side of the turbocharger (Figure 1). Discard the V-band coupling gaskets.

F. Disconnect the turbocharger from the exhaust transition and the pipe to the intercooler (Figure 2).

G. Disconnect the oil supply hose (Figure 4) from the turbocharger.

H. Remove the two bolts, washers, and lock washers from the oil drain tank (Figure 5) connection at the bottom of the turbocharger. Discard the lock washers and gasket.

I. Remove the two bolts, lock washers, washers, adapter and gasket (Figure 5) from the top of the turbocharger. Discard the gasket and lock washers.

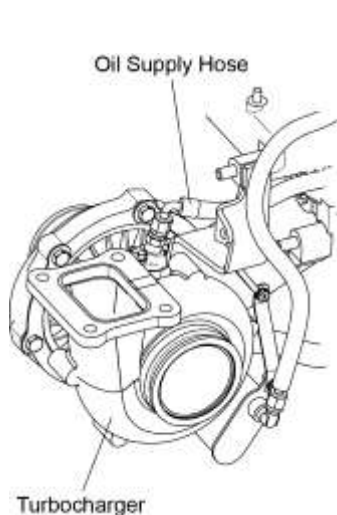


Figure 4
Turbocharger Oil Supply Hose

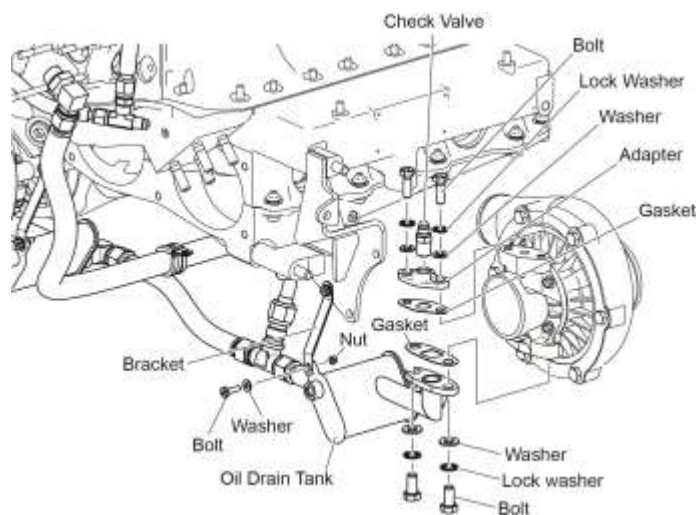


Figure 5
Turbocharger Oil Drain Tank Connections

- J. Remove the bolt, lock washer, and washer from the mounting bracket (Figure 6) and turbocharger. Discard the lock washer.
- K. Hold the turbocharger in place and remove the four bolts, washers, and lock nuts from the turbocharger and remove the turbocharger. Discard the lock nuts.
- L. Examine the check valve (Figure 5) to make sure it is clear and free of FOD. Replace as necessary per the turbocharger manufacturer's instructions.

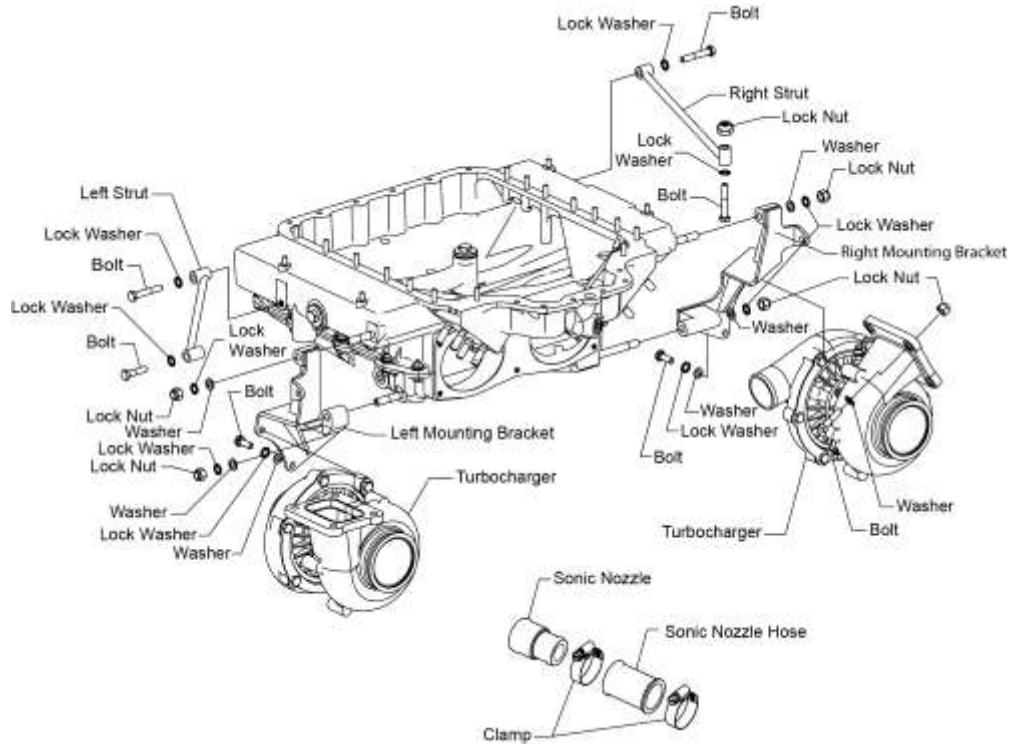


Figure 6
Turbocharger Mounting Brackets

6. Turbocharger Installation


⚠ CAUTION CRACKS AS WELL AS INCORRECT ASSEMBLY OR INSTALLATION OF THE TURBOCHARGER EXHAUST SYSTEM CAN ADVERSELY AFFECT ENGINE OPERATION, OR RESULT IN THE RELEASE OF HOT TOXIC GASES WHICH CAN CAUSE A FIRE AS WELL AS DAMAGE TO NEARBY COMPONENTS.

NOTICE: This procedure applies to installation of either turbocharger.


- A. Clean the turbocharger per the turbocharger manufacturer's instructions and remove any carbon deposits.
- B. Apply a thin coat of C5-A copper based anti-seize lubricant to the inside diameter of the four lock nuts (Figure 6) that attach the turbocharger and exhaust transition (Figure 1).
- C. Hold the turbocharger in place with the exhaust side mating flange against the respective left or right exhaust transition (Figure 1) that applies to left or right turbocharger. Install the four bolts through the turbocharger mating flange on the exhaust transition each with a washer and new lock nut. Torque the lock nuts as per torque values in the Standard Torque Tables in the latest revision of the *Service Table of Limits - SSP-1776*.

NOTICE: There are different part numbers for the left and right turbocharger mounting brackets, struts, and oil drain tanks. If the parts need to be replaced, refer to the *TEO-540-A1A Illustrated Parts Catalog* for the respective part number.

- D. Install the bolt, a new lock washer, and washer on the respective mounting bracket (Figure 6) and applicable turbocharger. Torque the bolt as per torque values in the Standard Torque Tables in the latest revision of the *Service Table of Limits - SSP-1776*.
- E. Install a new oil drain tank gasket (Figure 5) on the bottom of the turbocharger.
- F. Attach the oil drain tank to the turbocharger with two bolts, each with a washer and new lock washer. Torque the bolt as per torque values in the Standard Torque Tables in the latest revision of the *Service Table of Limits - SSP-1776*.
- G. Install the adapter with a new gasket on the top of the turbocharger with two bolts, each with a washer and a new lock washer. Torque the bolt as per torque values in the Standard Torque Tables in the latest revision of the *Service Table of Limits - SSP-1776*.
- H. Connect the oil supply hose (Figure 4) to the turbocharger.

 **CAUTION** DURING V-BAND COUPLING INSTALLATION, USE CARE NOT TO SPREAD OR FORCE THE COUPLING BEYOND ITS NORMAL OPEN POSITION TO PREVENT DISTORTION OF THE COUPLING. THIS DISTORTION CAN CAUSE AN INEFFECTIVE SEAL OR RUPTURE THE METAL WHICH CAN RESULT IN FAILURE OF THE COUPLING.

- I. Connect the intercooler pipe (Figure 2) to the turbocharger with a V-band clamp.

 **CAUTION** CRACKS AS WELL AS INCORRECT ASSEMBLY OR INCORRECT INSTALLATION OF THE TURBOCHARGER TO THE EXHAUST SYSTEM CAN ADVERSELY AFFECT ENGINE OPERATION, OR RESULT IN THE RELEASE OF HOT TOXIC GASES WHICH CAN CAUSE A FIRE AS WELL AS DAMAGE TO NEARBY COMPONENTS.

- J. Prior to attachment of the turbocharger to the exhaust system assembly:
 - (1) Clean all exhaust pipes between exhaust manifold connections and at all slip joints with a scuff pad. Remove all debris. Make sure the connecting/mating surfaces at slip joints are clean and that there is no residual debris.
 - (2) Examine all of the exhaust pipes and saddle welds for cracks, bulges, dents, damage, and correct fit. Replace any component that is cracked, bulged, dented, damaged or does not fit correctly.
 - (3) Apply C5A Copper Based Anti-Seize or equivalent to the threads on the exhaust studs.
 - (4) Begin assembly of the exhaust system at Cylinders Nos. 1 and 2 at the front of the engine and continue to the rear of the engine.
- K. When connecting exhaust pipes:
 - (1) Make sure the connecting/mating surfaces at slip joints are clean, and that there is no debris.
 - (2) Apply a uniform coating of C5A Copper Based Anti-Seize or equivalent around the entire circumference of exhaust pipes, between the exhaust manifold connection, and at all slip joints (to minimize binding).

- (3) Refer to the photo or sketch done before disassembly or Figure 1 to ensure correct assembly and installation of the exhaust pipes.

⚠ CAUTION WHEN INSTALLING EXHAUST SYSTEM COMPONENTS, INITIALLY TIGHTEN HARDWARE FASTENERS FINGER-TIGHT. DO NOT TIGHTEN ANY PART OF THE EXHAUST SYSTEM BEFORE PROCEEDING TO ANOTHER PART ON THE SAME SIDE OF THE ENGINE.

- L. Install exhaust system parts with hardware fasteners finger-tight to allow for adjustment in the next step.
- M. Align exhaust pipes in the correct configuration (per your photo or sketch) to enable engagement of the slip joints at the same distance for each joint. If there is binding at a slip joint or pipes at the V-band coupling are not aligned, loosen and re-install the components until they align correctly.

⚠ CAUTION DURING REPLACEMENT OF ANY EXHAUST PIPE, ALL OF THE FLANGE SURFACES MUST BE ACCURATELY ALIGNED. IF CROSSOVER EXHAUST COMPONENTS ARE INCORRECTLY ALIGNED, THEY CAN CAUSE TOO MUCH STRESS ON THE FLANGES OF THE CROSSOVER EXHAUST PIPES AND CAUSE GAS LEAKAGE AT SLIP JOINTS AND FLANGE JOINTS.

- N. Every time a V-band coupling is assembled on the exhaust system, install a new gasket within the coupling. Make sure that the seal is complete when a V-band coupling is assembled over an exhaust system component. (Refer to the latest revision of Service Instruction Nos. SI-1238 and SI-1562 for turbocharger exhaust system assembly and torque procedures for V-band couplings.)

⚠ CAUTION TORQUE HARDWARE FASTENERS EVENLY AND UNIFORMLY TO PREVENT LEAKS.

- O. Make sure there are no gaps at pipe connections and all pipes are correctly aligned before the final torque of the fasteners.
- P. Once the alignment and configuration are validated, torque the hardware fasteners for each attaching component equally and uniformly on each side, one component at a time as per the Standard Torque Tables in the latest revision of the *Service Table of Limits - SSP-1776*.
- Q. Connect the exhaust transition (Figure 1) to the exhaust side of the turbocharger with a V-band clamp.
- R. Remove any identifier labels applied during component removal.
- S. To prevent an accident caused by foreign object debris (FOD) make sure that no tools were left in the engine compartment.
- T. Install the cowling.
- U. Complete an operational ground check in Chapter 72-00 to make sure the engine is operating correctly before returning the engine to service.
- V. Record any turbocharger component replacement or work completed in the engine logbook.

7. Exhaust Bypass Valve Replacement

⚠ CAUTION PRIOR TO EXHAUST BYPASS VALVE REMOVAL, LET THE ENGINE AND THE EXHAUST SYSTEM COOL FOR 1 HOUR OR LONGER AFTER ENGINE SHUTDOWN TO PREVENT BURNS. ENSURE THAT THE BATTERY IS DISCONNECTED TO PREVENT ENGINE START.

A. Exhaust Bypass Valve Removal

- (1) Disconnect the bypass hose from the exhaust bypass valve (Figure 7).
- (2) Disconnect the wastegate control hose from the exhaust bypass valve.
- (3) Remove the V-band coupling and gasket that attaches the exhaust bypass valve to the exhaust transition. Discard the gasket.
- (4) Remove the exhaust bypass valve.

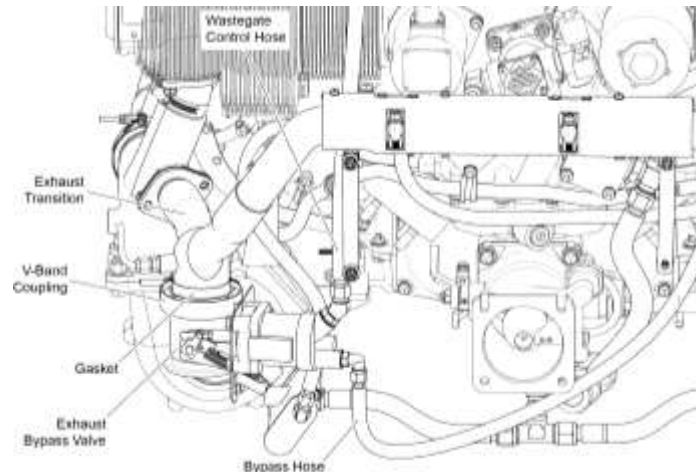


Figure 7
Exhaust Bypass Valve

B. Exhaust Bypass Valve Installation

- (1) Attach the exhaust bypass valve to the exhaust transition with the V-band coupling and new gasket (Figure 7).
- (2) Torque the V-band coupling per the Standard Torque Tables in the latest revision of the *Service Table of Limits - SSP-1776*.
- (3) Connect the wastegate control hose to the exhaust bypass valve. Torque the wastegate control hose fitting per the Standard Torque Tables in the latest revision of the *Service Table of Limits - SSP-1776*.
- (4) Connect the bypass hose to the exhaust bypass valve. Torque the bypass hose fitting per the Standard Torque Tables in the latest revision of the *Service Table of Limits - SSP-1776*.

72-50 - LUBRICATION SYSTEM MAINTENANCE

1. Oil Pressure Adjustment

NOTICE: There is an adjustment screw (Figure 1) on the oil pressure relief valve housing. Rotation of this screw either increases or decreases the oil pressure to keep it within the specified operational limits in Appendix A of the *TEO-540-A1A Engine Installation and Operation Manual*.

- A. The engine must be installed in the aircraft or on a test stand to complete this procedure.
- B. Start and operate the engine per instructions in the *TEO-540-A1A Engine Installation and Operation Manual*.
- C. If the engine is at normal operating temperature, run-up the engine to 2000 rpm.
- D. Record the oil pressure reading.
- E. If the oil pressure is out of tolerance, turn off the engine and adjust the oil pressure as follows:
 - To **increase** oil pressure, turn the pressure adjustment screw on the oil pressure relief valve **clockwise** (Figure 1).
 - To **decrease** oil pressure, turn the adjustment screw on the oil pressure relief valve **counterclockwise**.
- F. Start the engine and repeat the previous steps until the oil pressure is within specified limits.

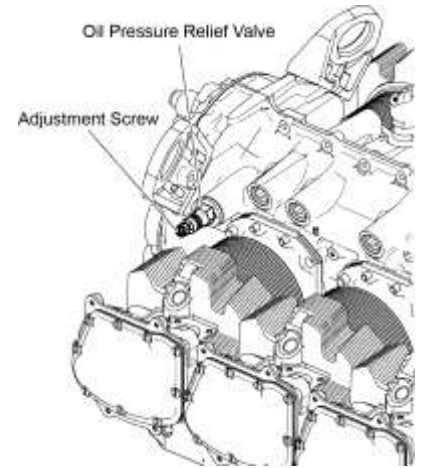


Figure 1
Adjustment Screw on the Oil Pressure Relief Valve

NOTICE: If the oil pressure cannot be adjusted to within specified limits by turning the adjustment screw, refer to the “Oil Pressure Relief Valve Removal”, “Oil Pressure Relief Valve Inspection”, and “Oil Pressure Relief Valve Installation” sections in this chapter.

2. Oil System Inspection

- A. Look for leaks around the oil sump and crankcase flanges.
- B. If there are indications of leakage around the oil seals and gaskets, identify the source of the leak and take corrective action as necessary. Record findings and corrective action in the engine logbook.
- C. Replace leaky oil seals and gaskets.
- D. Complete an Operational Ground Check per Chapter 72-00 to make sure the engine operates correctly and that there are no leaks.

3. Oil Hose Inspection

CAUTION MAKE SURE THERE ARE NO SHARP BENDS OR KINKS IN THE OIL HOSE ROUTING TO PREVENT INTERRUPTIONS TO OIL FLOW. MAKE SURE OIL HOSES ARE NOT TOUCHING HEAT SOURCES THAT COULD DAMAGE THE OIL HOSE AND CAUSE OIL LOSS.

- A. Examine oil hoses for cracks, kinks, brittleness, wear, damage or loose connections. Replace any worn, cracked, kinked, damaged, or brittle oil hose with a new oil hose per the “Oil Hose Replacement” procedure in this chapter. Do not try to repair the oil hose.
- B. Tighten any loose connection at an oil hose per the torque values in the Standard Torque Tables in the latest revision of the *Service Table of Limits - SSP-1776*.

4. Oil Hose Replacement (General Instructions for Any Oil Hose)

- A. Disconnect, drain, and discard the oil hose.

⚠ CAUTION DO NOT TRY TO REPAIR AN OIL HOSE. REPLACE A BRITTLE, CRACKED, KINKED, OR DAMAGED OIL HOSE.

- B. Ensure the new oil hose is free from obstructions before installing.

- C. Install a new oil hose; do not let the oil hose touch a heat source.

⚠ CAUTION MAKE SURE THERE ARE NO SHARP BENDS OR KINKS IN THE OIL HOSE ROUTING TO PREVENT INTERRUPTIONS TO OIL FLOW. MAKE SURE OIL HOSES ARE NOT TOUCHING HEAT SOURCES THAT COULD DAMAGE THE HOSE AND CAUSE OIL LOSS.

- D. Make sure there are no sharp bends or kinks in the oil line routing

- E. Torque the fitting connections on the oil hose ends in accordance with the torque values in the Standard Torque Tables in the latest revision of the *Service Table of Limits - SSP-1776* and aircraft manufacturer's instructions.

5. Oil Filler Extension and Oil Level Gage Assembly Removal

- A. Remove and discard the safety wire/cable (Figure 2) from the oil filler extension.

- B. Remove the oil level gage assembly from the oil filler extension (Figure 3).

- C. Examine the O-ring for damage and wear. Replace a damaged or worn O-ring.

- D. Carefully turn the oil filler extension (Figure 3) to remove the oil filler extension and gasket from the engine. Discard the gasket.

- E. Put the oil level gage assembly and oil filler extension on a clean surface in a safe place to prevent damage to the components and contamination.



Figure 2
Safety Wire on the Oil Filler Extension

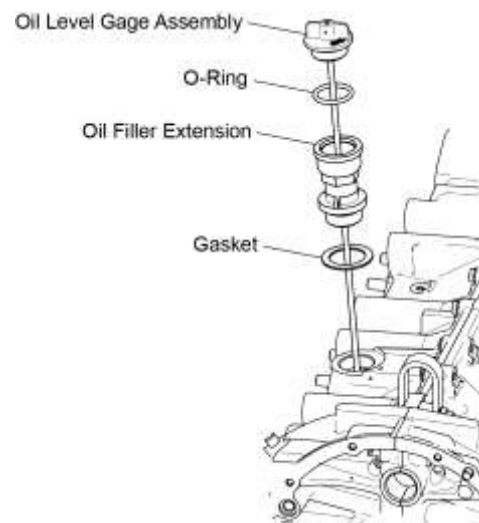


Figure 3
Oil Level Gage

6. Oil Filler Extension and Oil Level Gage Assembly Installation

- A. Apply Food-Grade Anti-Seize to the threads of the top and bottom of the oil filler extension (Figure 3) and to the threads on the oil level gage assembly.
- B. Install a new gasket on the bottom threads of the oil filler extension.
- C. Install the oil filler extension with the new gasket on the engine.
- D. Install a serviceable O-ring on the oil level gage assembly.

⚠ CAUTION TO PREVENT CONTAMINATION OF THE OIL IN THE SUMP, MAKE SURE THE OIL LEVEL GAGE ASSEMBLY DIPSTICK IS WIPED CLEAN AND DOES NOT HAVE ANY DEBRIS OR CONTAMINATION.

- E. Install the oil level gage assembly into the oil filler extension.
 - F. Safety wire/cable the oil filler extension as shown in Figure 2. Refer to the latest revision of Service Instruction No. SI-1566.
- ## 7. Oil Pressure Relief Valve Removal
- A. Remove and discard the safety wire/cable from the oil pressure relief valve (Figure 4).
 - B. Remove the oil pressure relief valve, spring, ball, and gasket (Figure 5) from the crankcase. Discard the gasket.



Figure 4
Safety Wire on the Oil Pressure Relief Valve

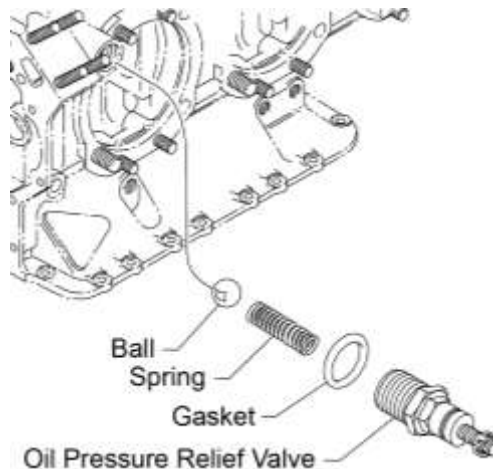


Figure 5
Oil Pressure Relief Valve

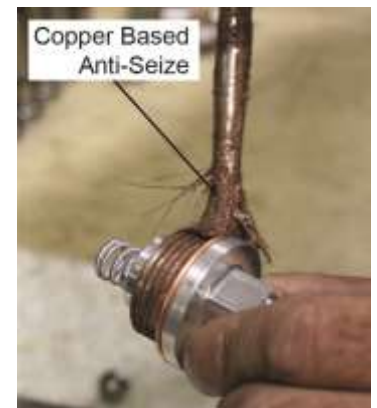


Figure 6
Apply Copper Based Anti-Seize to Threads

8. Oil Pressure Relief Valve Inspection

- A. Examine the oil pressure relief valve spring to be sure it meets specifications in accordance with the latest revision of the *Service Table of Limits - SSP-1776*.
- B. Examine the threads on the oil pressure relief valve. If the threads are stripped or galled, replace the valve.

9. Oil Pressure Relief Valve Installation

- A. Install a new gasket on the oil pressure relief valve (Figure 5).

NOTICE: Refer to the Special Torque Requirements Tables in Section V in the latest revision of *Service Table of Limits - SSP-1776* to select the correct spring.

- B. Install the spring in the oil pressure relief valve (Figure 5).
- C. Apply Copper-Based Anti-Seize to the threads of the oil pressure relief valve as shown in Figure 6.
- D. Install the ball in the crankcase.
- E. Install the oil pressure relief valve (with the spring) in the crankcase and torque to 300 in.-lb. (34 Nm).
- F. Safety wire/cable the oil pressure relief valve as shown in Figure 4. Refer to the latest revision of Service Instruction No. SI-1566.

10. Oil Cooler Bypass Valve Removal

- A. Remove and discard the safety wire/cable from the oil cooler bypass valve.
- B. Remove the oil cooler bypass valve (Figure 7) from the oil accessory housing. Discard the gasket.

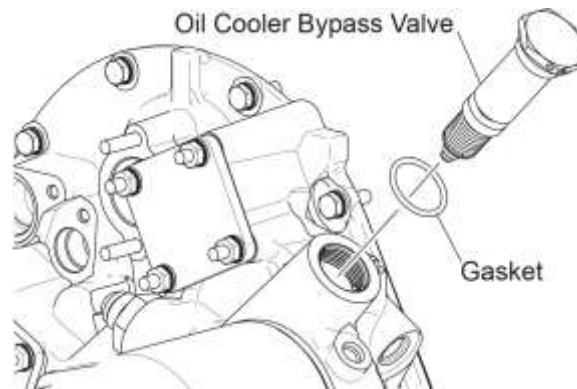


Figure 7
Oil Cooler Bypass Valve

11. Oil Cooler Bypass Valve Cleaning

Clean the oil cooler bypass valve per instructions in the table in Chapter 05-30.

12. Oil Cooler Bypass Valve Installation

- A. Apply Food Grade Anti-Seize on the threads of the oil cooler bypass valve.
- B. Install the oil cooler bypass valve with a new gasket in the accessory housing as shown in Figure 7.
- C. Torque the oil cooler bypass valve to 300 in.-lbs. (34 Nm).
- D. Safety wire/cable the oil cooler bypass valve. Refer to the latest revision of Service Instruction No. SI-1566.

13. Oil Sump Removal

A. Drain oil from the oil sump per the “Oil Change Procedure” in Chapter 12-10.

B. Per the respective removal instructions in Chapter 72-80:

(1) Remove the intake pipes from the engine.

(2) Remove the induction housing.

C. Remove the throttle body assembly and gasket per instructions in Chapter 73-20.

NOTICE: Since there are different length bolts installed on the oil sump, keep bolts, nuts, and washers removed in each of the following steps separate from bolts, nut, and washers removed in other steps.

Draw a sketch or refer to the *TEO-540-A1A Illustrated Parts Catalog* to identify the location of different length bolts installed on the oil sump.

D. Remove the six bolts, six nuts, six lock washers, 12 washers, and six nuts (Figure 8) from the accessory housing end of the oil sump. Discard the lock washers.

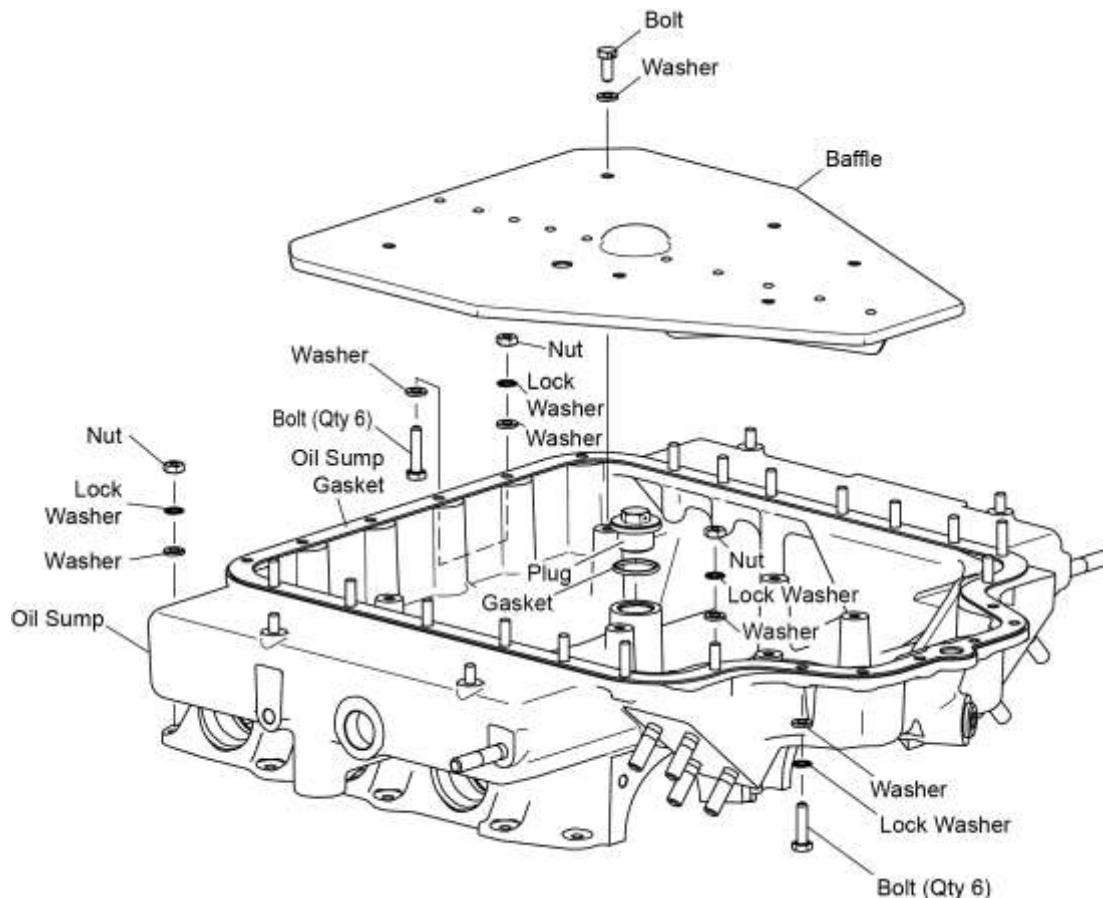


Figure 8
Oil Sump

E. Remove the six bolts, six lock washers, and 12 washers from the propeller end of the oil sump. Discard the lock washers. Keep these longer bolts separated from the bolts removed in the previous step.

- F. While one person holds the oil sump, remove the 15 nuts, 15 lock washers, and 15 washers from the left and right sides of the oil sump (Figure 8).
- G. Remove the oil sump from the engine.
- H. Remove and discard the oil sump gasket.
- I. Examine all of the oil sump bolts that were to be kept separate when the oil sump was removed. Make sure the bolts, studs, and nuts are not damaged are intact and have no stripped threads. Replace any damaged or stripped fastener.

NOTICE: If studs are not already installed on the oil sump, install new studs in their corresponding location per Figure 8.

Refer to the latest revision of the *Service Table of Limits - SSP-1776* for the minimum driving torque of the studs. Use a tool maker's square to complete a check of the stud alignment.

There are different length bolts used to attach the oil sump to the crankcase, keep the bolts separated to make sure the correct length bolt is installed in the correct location.

- J. Turn over or cover the oil sump to prevent dirt and debris from getting in the oil sump.

14. Oil Sump Inspection

- A. Examine the oil sump for any raised metal on surfaces and for any scratch, ding, dent, or pit, that exceeds 0.050 in. (1.27 mm) depth.
- B. Replace the oil sump if there is any raised metal on surfaces or if a scratch, ding, dent, or pit, that exceeds 0.050 in. (1.27 mm) depth is found on the sump.
- C. Examine the oil sump baffle for cracks or distortion. If cracks are found replace the baffle and Refer to the latest revision of the *Service Table of Limits - SSP-1776* for the minimum driving torque of the attaching bolts, and safety wire.

15. Oil Sump Installation

- A. Clean the mating flange and interior of the oil sump with mineral spirits.
- B. Remove all gasket material on the flange. Make sure the oil sump has no cracks or damage, is clean and has no dirt, debris, or other foreign object matter that could contaminate the oil supply for the engine.
- C. Remove (cut away) any excess accessory housing gasket material that extends to the oil sump mounting surface. Excess gasket material must not extend between the accessory housing and crankcase. The gasket must be flush with the oil sump flange (Figure 9).
- D. Remove, clean, and install the oil suction screen per instructions in Chapter 12-10.

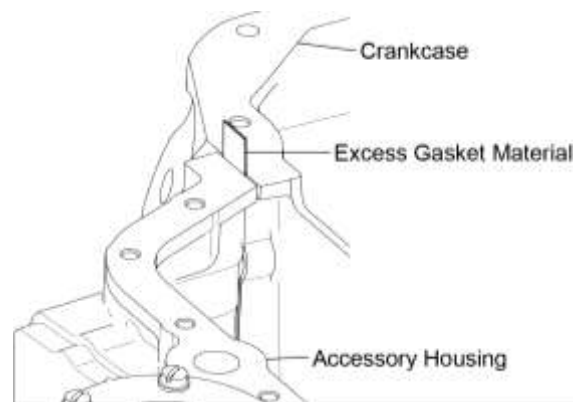


Figure 9
Remove Excess Accessory Housing Gasket Material to Make It Flush with the Oil Sump Flange

- ⚠ CAUTION** TO PREVENT OIL LEAKAGE, DO NOT INSTALL A CRACKED OR DAMAGED OIL SUMP. REPLACE WITH A CLEAN INTACT OIL SUMP. THE OIL SUMP MUST BE CLEAN, WITHOUT DIRT, DEBRIS, OR OTHER FOREIGN OBJECT MATTER THAT COULD CONTAMINATE THE OIL SUPPLY. CONTAMINATED OIL CAN ADVERSELY AFFECT ENGINE OPERATION.

- E. Apply a dab of POB Gasket Sealant #4 (or equivalent) to three places in the split line between the accessory housing and crankcase where they mate with the oil sump (Figure 10).

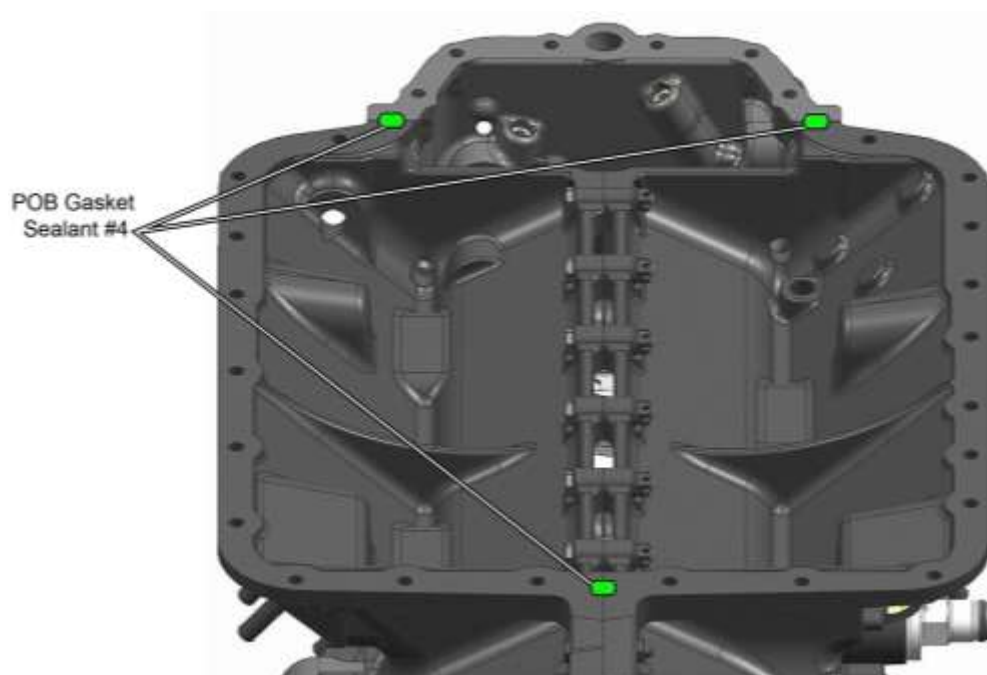


Figure 10


Apply POB Gasket Sealant #4 (or Equivalent) to Three Places on the Oil Sump

- F. Install a new oil sump gasket in the oil sump groove (Figure 8).
G. Align the oil sump flange with the bottom of the mated crankcase halves.

- ⚠ CAUTION** ALL OF THE OIL SUMP FASTENERS (STUDS, BOLTS, AND NUTS) MUST BE INTACT TO ENSURE CORRECT AND SECURE TIGHTENING TO PREVENT OIL LEAKAGE AT THE OIL SUMP MATING FLANGE WITH THE CRANKCASE. NO OIL IS TO LEAK OUT OF THE OIL SUMP.

- H. Examine all of the oil sump fasteners identified in Figure 8, that were to be kept separate when the oil sump was removed. Make sure the bolts, studs, and nuts are not damaged are intact and have no stripped threads. Replace any damaged or stripped fasteners.
I. While one person holds the oil sump, install the 15 nuts, 15 new lock washers, and 15 washers on the left and right sides of the oil sump (Figure 8).
J. Install the six bolts, six new lock washers, and six washers on the propeller end of the oil sump.

- K. Install the six bolts, six new lock washers, 12 washers, and six nuts on the accessory housing end of the oil sump.
- L. Torque all of the nuts and bolts to 96 in.-lb. (11 Nm).
- M. Apply one to two drops of Loctite[®] 564[™] to the threads of each oil sump drain plugs and install the oil sump drain plugs in the oil sump. Torque the drain plugs in accordance with the Standard Torque Tables in the latest revision of the *Service Table of Limits - SSP-1776*.

 **CAUTION** MAKE SURE THAT THE OIL SUMP DRAIN PLUGS ARE INSTALLED TIGHTLY. IF THE DRAIN PLUGS ARE NOT TIGHTLY INSTALLED AND LEAK, ENGINE FAILURE CAN OCCUR.

- N. Safety cable/wire the oil sump drain plugs (and oil suction screen if not already done) in accordance with the standard practices per the latest revision of AC43.13-1B or the latest revision of Service Instruction No. SI-1566.
- O. Install the induction housing intake pipes on the engine per respective installation instructions in Chapter 72-80.
- P. Install the throttle body assembly per instructions in Chapter 73-20.
- Q. After maintenance is completed, complete the “Add Oil to the Engine” procedure.
- R. Complete the “Operational Ground Check” per Chapter 72-00.

72-60 - ACCESSORY DRIVES

1. Accessory Drive Inspection
 - A. Look for damage to engine-mounted accessories such as pumps. Replace damaged accessories.
 - B. Make sure any attached accessories are attached securely at the correct torque. Refer to the latest revision of the *Service Table of Limits - SSP-1776* for torque values and tighten any loose hardware as necessary.
2. Vacuum Pump Replacement (if installed)
 - A. Vacuum Pump Removal

Remove the vacuum pump (Figure 1) from the accessory drive housing in accordance with the aircraft manufacturer's instructions.



Figure 1
Vacuum Pump

- B. Vacuum Pump Installation

Install the vacuum pump (Figure 1) on the accessory drive housing in accordance with the aircraft manufacturer's instructions.
3. Vacuum Pump Driven Gear Replacement (if installed)

A. Vacuum Pump Driven Gear Removal

- (1) Remove the four nuts, lock washers, and washers from the vacuum pump adapter or vacuum pump cover (Figure 2). Discard the lock washers.

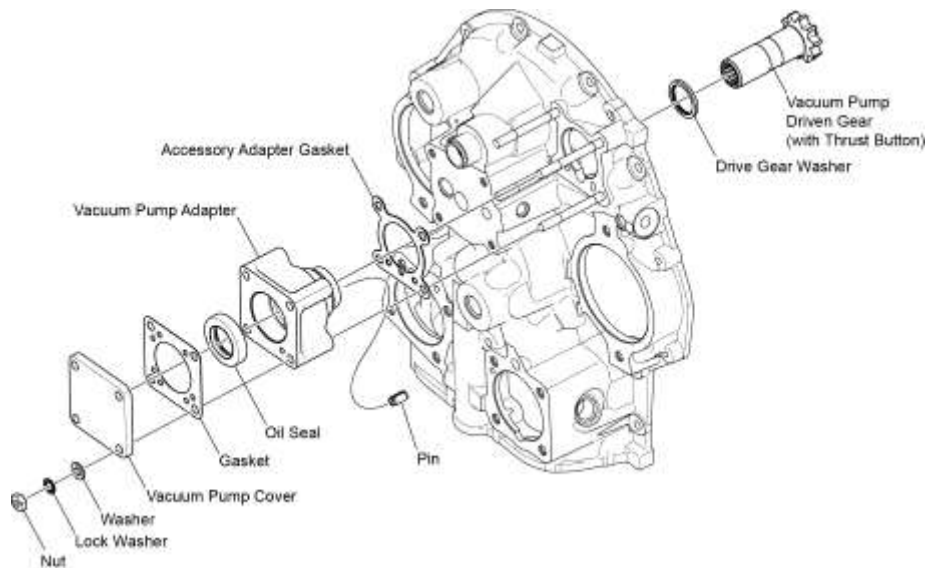


Figure 2
Vacuum Pump Drive and Cover

- (2) Remove the vacuum pump or vacuum pump cover, gasket, and oil seal from the vacuum pump adapter. Discard the gasket and oil seal.
- (3) Examine the oil seal for wear and damage. If necessary remove the oil seal with Seal Puller P/N ST-172, discard, and replace.
- (4) Remove and discard the pin from the vacuum pump adapter.

- (5) Remove the vacuum pump adapter, the accessory drive gasket, the drive gear washer from the vacuum pump driven gear. Discard the accessory drive gasket.
- (6) Remove the vacuum pump driven gear (and thrust button within the gear) from the accessory housing.
- (7) Remove any remaining gasket material from the vacuum pump or vacuum pump cover, vacuum pump adapter, and accessory housing mounting surface per instructions in the table in Chapter 05-30.

B. Vacuum Pump Driven Gear Installation

- (1) Apply engine oil mixture to the vacuum pump driven gear.
- (2) Install a new pin in the vacuum pump adapter.
- (3) Install the vacuum pump driven gear (with the thrust button already installed inside the geared end) and drive gear washer in the vacuum pump adapter (Figure 2).
- (4) Install a new accessory adapter gasket on the vacuum pump adapter in the correct orientation as shown in Figure 2.
- (5) Install the vacuum pump adapter with a serviceable oil seal on the accessory housing as shown in Figure 2.
- (6) Install the vacuum pump with a new gasket on the vacuum pump adapter in accordance with the aircraft manufacturer's instructions.
or
Install the vacuum pump cover and new gasket with four nuts, new lock washers, and washers on the vacuum pump adapter. Torque the nuts to 96 in.-lb. (11 Nm)

72-70 - ELECTRICAL SYSTEM MAINTENANCE

1. Wiring Inspection

⚠ CAUTION USE CAUTION AROUND THE WIRING HARNESS, SENSORS AND ACTUATORS. THEY CAN BE EASILY DAMAGED AND CANNOT BE REPAIRED. IF ANY OF THESE ITEMS ARE DAMAGED, THEY MUST BE REPLACED. IF ONE WIRE BREAKS ON THE WIRING HARNESS, THE COMPLETE HARNESS WILL NEED TO BE REPLACED.

NOTICE: This inspection procedure applies to either of the wiring harnesses (engine-to-firewall, fuselage harness, and the airframe interface wiring harness).

- A. Examine the wiring on each harness for correct routing, security, clamping, deterioration, damage, wear, fraying, chafing or breaks in accordance with the airframe manufacturer's instructions.
- B. Look for heat damage on the wiring and on the engine in galleys and behind lights. Though a visual inspection of the wiring harness can identify heat damage, burnt wire, vibration damage, or chafing, a more detailed inspection is necessary to identify cracked insulation, arcing, and worn insulation. Identify and correct the cause of any heat damage.

NOTICE: There must not be any repairs or splices on the harness. Replace the harness if repairs or splices are found.

- C. Replace the harness if there is damage to the wiring and connectors that came in contact with the chemicals and fluids:

- | | |
|---|---------------------|
| (1) Hydraulic fluid | (5) Cleaning agents |
| (2) Battery electrolytes | (6) De-icing fluid |
| (3) Fuel corrosion inhibiting compounds | (7) Paint |
| (4) Waste system chemicals | |

- D. Replace the harness if any of the following conditions are found on the harness.

- | | |
|--|--|
| (1) Broken, frayed, chafed, worn, degraded or damaged wire | (4) Vibration damage or chafing |
| (2) Repairs or splices | (5) Cracked or worn insulation |
| (3) Heat damage or burnt wire | (6) Arcing |
| | (7) Broken or damaged sensor connector |

- E. Examine all of the wiring connections and accessories for physical damage and security. Refer to Appendix D of the *TEO-540-A1A Engine Installation and Operation Manual* for wiring harness connections.

⚠ CAUTION ANY TIME AN ELECTRICAL CONNECTOR IS DISCONNECTED, INSTALL A CAP ON THE CONNECTOR TO PREVENT DAMAGE OR CONTAMINATION FROM FOD, CHEMICALS, OR FLUIDS.

- F. Examine each connector for the sensors and actuators on the harness. If a connector is damaged, replace the harness.
- G. Examine the harness connector and airframe receptacles for the aircraft interface and airframe power. Look closely at the pins and sockets. If a receptacle is damaged, repair or replace the receptacle as per the airframe manufacturer's instructions.
- H. To replace damaged cables or clamps, refer to the aircraft manufacturer's instructions.
- I. Examine the terminals for correct installation, tightness, and cleanliness. Wipe away dirt on the terminal. Tighten terminals as per the torque values in the Standard Torque Tables in the latest revision of the *Service Table of Limits - SSP-1776*.

2. Alternator Belt Inspection

- A. Examine the alternator belts (Figure 1) for any cracks, damage, or wear.
- B. Complete the “Alternator Belt Tension Check/Adjustment” procedure in this chapter.
- C. Replace a worn, cracked or damaged alternator belt per instructions in the “Alternator Belt Replacement” section in this chapter.

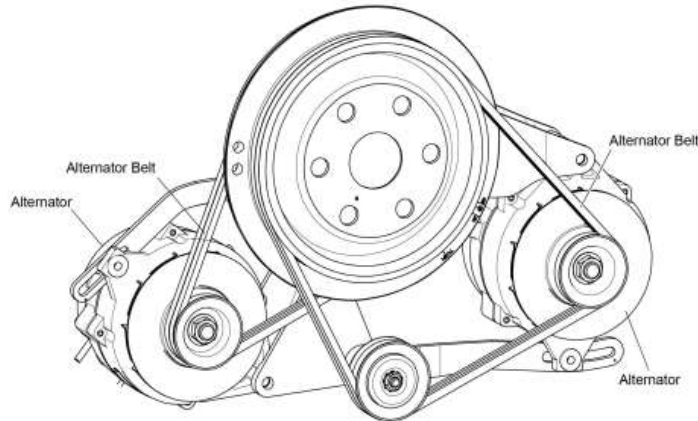


Figure 1
Alternator Belts

3. Alternator Belt Tension Check/Adjustment

⚠ CAUTION IF THE ALTERNATOR BELT TENSION IS NOT SET CORRECTLY, THE ALTERNATOR BELT CAN SLIP, WEAR PREMATURELY, AND DECREASE ELECTRICAL OUTPUT.

- A. When to complete an alternator belt tension check.
 - (1) Immediately after the alternator belt is replaced and then after 25 hours of operation after installation.
 - (2) During each 100-hour service inspection thereafter.
- B. Use any of the following three methods to complete an alternator belt tension check:
 - Torque Method
 - Deflection Method
 - Belt Tension Gage Method

NOTICE: Refer to the latest revision of Service instruction SI-1129 for any new details on alternator belt tension check.

- (1) Torque Method (measure the torque required to slip the belt at the small pulley as follows):
 - (a) Hold and secure the propeller to prevent rotation of the crankshaft.
 - (b) Apply a torque indicating wrench to the nut that attaches the pulley to the alternator and turn it clockwise.
 - (c) Compare the torque value on the torque indicating wrench necessary to slip the belt at the small pulley to the specified torque for the width and condition of the belt identified in Table 1.

- (d) If the torque does not agree with Table 1 for a new alternator belt, complete the “Alternator Belt Tension Adjustment” procedure for the respective alternator in this chapter.

Table 1
Required Torque (Belt Tension)

Width of Belt	Condition of Belt	Torque at Pulley		Condition of Belt	Torque at Pulley	
		ft.-lb.	Nm		ft.-lb.	Nm
Twin 3/8 inch	New	22 to 26	30 to 35	Used*	14 to 18	19 to 24

* A belt is considered used if it has been installed on the engine and the engine has been operated.

(2) Deflection Method

- Attach the hook of a small spring-scale to the alternator belt at the approximate mid-point between the ring gear support and the alternator.
- Pull on the scale until a reading of 14 lb. (6.4 kg), is shown for a new belt.
- Measure the distance the alternator belt has moved with the 10 or 14 lb. (4.5 to 6.4 kg) load applied.
- The distance (deflection) is to be 5/16 in. (7.94 mm). If less than 5/16 in. (7.94 mm), the alternator belt tension is too tight.
- Adjust the belt tension as required to get the 5/16 in. (7.94 mm) distance (deflection) per the “Alternator Belt Tension Adjustment” procedure for the respective alternator in this chapter.

(3) Belt Tension Gage Method using Lycoming Belt Tension Gage (ST-131):

- Extend the hook on the Belt Tension Gage ST-131 (Figure 2) to its extreme position by depressing the handle.
- Put the hook over the alternator belt with the nose piece centered on the alternator belt.



Figure 2
Belt Tension Gage - ST-131

NOTICE: In the next step, release the handle of the Belt Tension Gage (ST-131) quickly. If the handle is released slowly internal friction will cause an inaccurate reading.

- Quickly release the handle of the Belt Tension Gage (ST-131) and read the indicated belt tension on the dial (Figure 3).
- Repeat the previous steps several times to ensure an accurate reading.
- If the tension reading on the alternator belt is out of tolerance, adjust the belt tension per the “Alternator Belt Tension Adjustment” procedure for the respective alternator in this section to get the appropriate reading on the Belt Tension Gage (ST-131).



Figure 3
Indicator on the Belt Tension Gage (ST-131)

C. Alternator Belt Tension Adjustment for the Left Alternator

- (1) Remove the safety wire/cable from the bolt in the alternator/idler adjusting link and left alternator (Figure 4).
- (2) Loosen the alternator adjusting bolt in the alternator/idler adjusting link and left alternator (Figure 5).
- (3) Rotate the alternator on the bracket to adjust the alternator belt tension.
- (4) Torque the bolt in the alternator adjusting link in accordance with the Standard Torque Tables in the latest revision of the *Service Table of Limits - SSP-1776*.
- (5) Complete the “Alternator Belt Tension Check/Adjustment” procedure in this chapter.
- (6) Install new safety wire/cable on the bolt on the alternator/idler adjusting link as shown in Figure 4.



Figure 4
Safety Wire/Cable on Bolts
of Alternator Adjusting Link

D. Alternator Belt Tension Adjustment for the Right Alternator

- (1) Remove the safety wire/cable from the two bolts in the right alternator adjusting link (Figure 4).
- (2) Loosen the alternator adjusting bolt in the right alternator adjusting link and right alternator (Figure 5).
- (3) Loosen the alternator adjusting bolt in the right alternator adjusting link and crankcase (Figure 5).
- (4) Rotate the alternator on the bracket to adjust the alternator belt tension.
- (5) Torque the two bolts in the right alternator adjusting link in accordance with the Standard Torque Tables in the latest revision of the *Service Table of Limits - SSP-1776*.
- (6) Complete the “Alternator Belt Tension Check/Adjustment” procedure in this chapter.
- (7) Install new safety wire/cable on the two bolts on the right alternator adjusting link as shown in Figure 4.

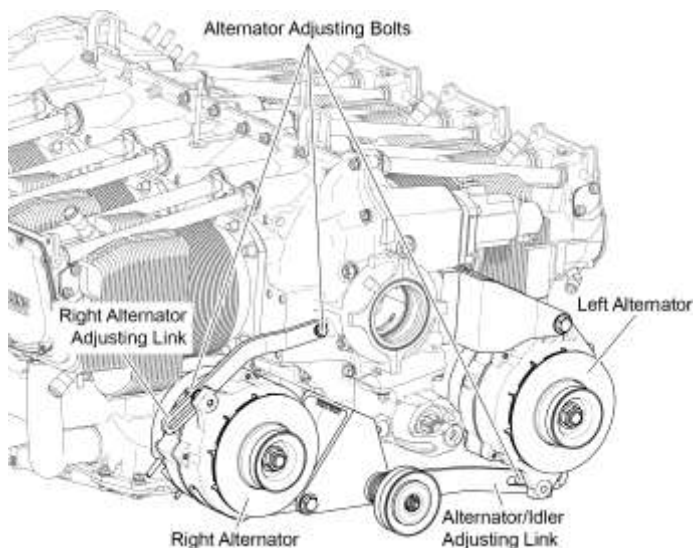


Figure 5
Alternator Belt Tension Adjusting Bolts
(Starter ring gear support and alternator belts removed from figure to show bolt locations)

4. Power Box and PMA

- A. The power box does not have regularly scheduled maintenance procedures. The power box is not field repairable. It only can be replaced.
- B. The Permanent Magnet Alternator (PMA) does not have regularly scheduled maintenance procedures. The PMA is not field repairable.

5. The Electrical System Includes Three Wiring Harnesses (Figure 6):

- Engine-to-firewall wiring harness - attaches to the engine and connects to the fuselage wiring harness through firewall connectors.
- Fuselage wiring harness - attaches to the ECU and power box; also attaches to the engine-to-firewall wiring harness through firewall connectors.
- Airframe interface wiring harness - supplied by the airframe manufacturer and connects aircraft power to the power box; it is the engine-to-operator interface (airframe avionics, ignition).

NOTICE: Refer to Appendix D in the TEO-540-A1A Engine Installation and Operation Manual for wiring harness designations.

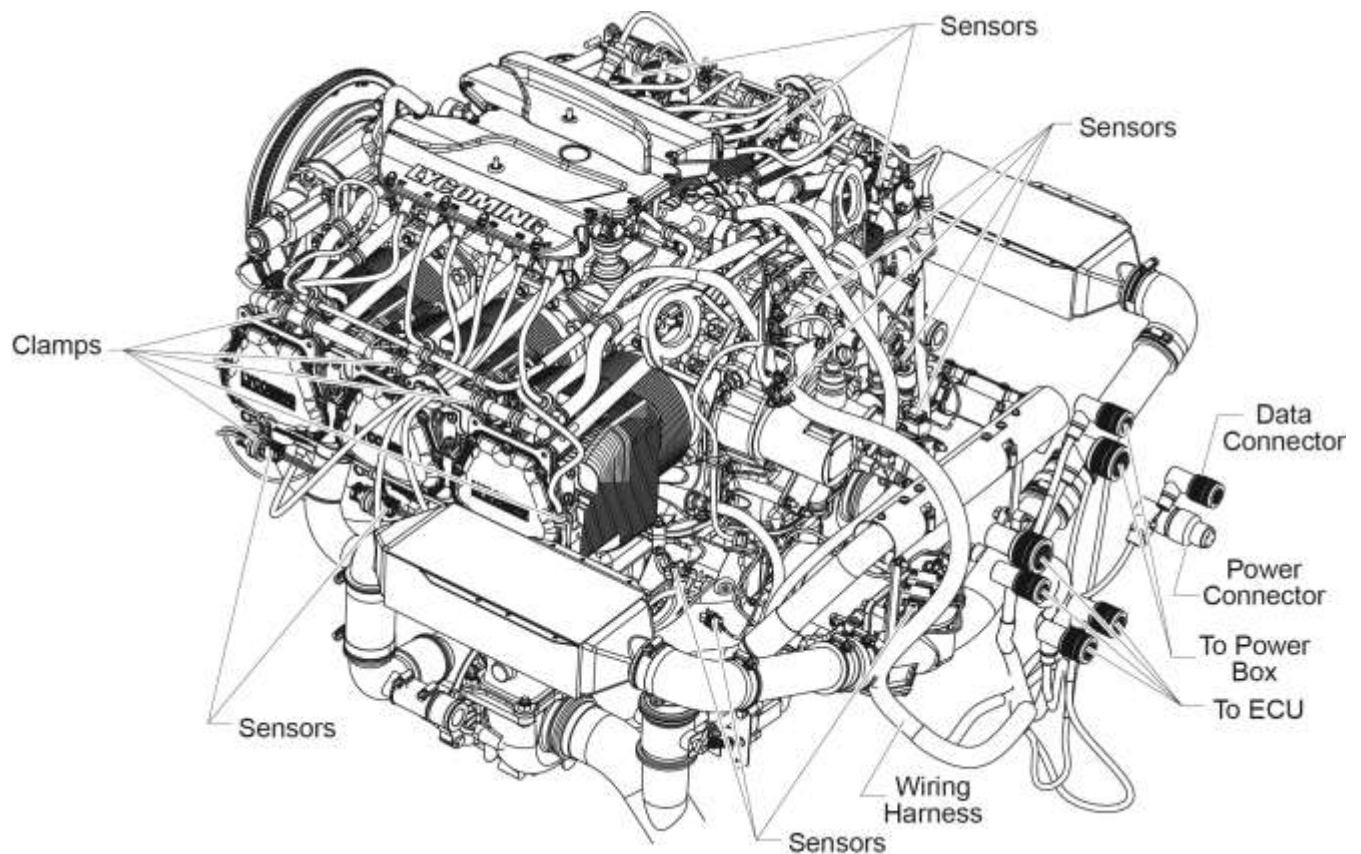


Figure 6
Wiring Harness Diagram

6. Wiring Harness Connectors

Several different types of wire connectors are used to connect the wiring harness to the sensors, actuators, and components installed on the engine. Table 2 identifies the different types of connectors and guidelines for disconnecting and connecting the wiring harness. Failure to follow the guidelines in table 2 for disconnecting and connecting the wiring harness could result in damage to the connector or the locking feature of the connector.

⚠ CAUTION USE CAUTION AROUND THE WIRING HARNESS, SENSORS AND ACTUATORS. THEY CAN BE EASILY DAMAGED AND CANNOT BE REPAIRED. IF ONE WIRE BREAKS ON THE WIRING HARNESS, THE COMPLETE HARNESS WILL NEED TO BE REPLACED.

USE CAUTION WHEN DISCONNECTING WIRING HARNESS CONNECTORS. NEVER PULL ON THE WIRES WHEN DISCONNECTING WIRING HARNESS CONNECTORS. NEVER USE A KNIFE BLADE OR SCREWDRIVER TO LIFT A LOCKING TAB. IF NECESSARY, USE A THIN PIECE OF WOOD OR PLASTIC TO LIFT THE LOCKING TAB.

ANY TIME AN ELECTRICAL CONNECTOR IS DISCONNECTED, INSTALL A CAP ON THE CONNECTOR TO PREVENT DAMAGE OR CONTAMINATION FROM FOD, CHEMICALS, OR FLUIDS.

NOTICE: Petrolatum or DC-4 lubricant or equivalent can be applied as necessary to the mating surfaces of connectors.

Table 2
Wiring Harness Connector Guidelines










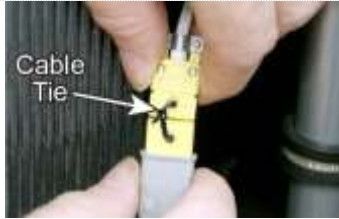

Sensor Name	Abbr.	Guidelines for Disconnecting and Connecting
Crankshaft Speed Sensor	CRANK	   <p>Figure 7 Speed Sensor Connector</p> <p>Figure 8 Press the Wire Locking Spring</p> <p>Figure 9 Separate the Connector</p>
Camshaft Speed Sensor	CAM	<p>The wiring harness connector for the Crankshaft and Camshaft Speed Sensors (Figure 7) are located on the accessory housing end of the engine. Refer to Figure 34.</p> <p>Disconnect:</p> <ol style="list-style-type: none"> 1. Hold the two parts of the connector, one in each hand. 2. Press the wire locking spring (Figure 8). 3. Separate to connector parts (Figure 9). <p>Connect:</p> <ol style="list-style-type: none"> 1. Hold the two parts of the connector, one in each hand. 2. Press the wire locking spring (Figure 8). 3. Insert the male connector into the female connector firmly and release the wire locking spring.






Table 2 (Cont.)
Wiring Harness Connector Guidelines

Sensor Name	Abbr.	Guidelines for Disconnecting and Connecting
Oil Temperature Sensor	OIL-T	 <p>Figure 10 Press the Rear of the Hinged Locking Tab</p>  <p>Figure 11 Wiring Harness Connector Removed from the Sensor</p>
Fuel Temperature Sensor	FUEL-T	<p>The wiring harness connectors for the Oil Temperature Sensor and Fuel Temperature Sensor connect directly to the sensor. The Oil Temperature Sensor is located near the oil filter (Figure 34) and the Fuel Temperature Sensor is installed in the fuel manifold (Figure 34).</p> <p>Disconnect:</p> <ol style="list-style-type: none"> 1. Press the rear of the hinged locking tab (Figure 10) to release it from the locking feature on the sensor and pull the wiring harness connector from the sensor (Figure 11). <p>Connect:</p> <ol style="list-style-type: none"> 1. Insert the wiring harness connector into the sensor and press firmly until you hear the hinged locking tab click in place.
Fuel Pump Pressure Sensor	FPP	 <p>Figure 12 Oil Pressure Sensor</p>  <p>Figure 13 Wiring Harness Connector Removed from the Sensor</p>
Fuel (Rail) Pressure Sensor	FUEL-P	
Induction Delta Pressure Sensor	DPS	<p>Pressure sensor connectors have a single locking tab on the wiring harness connector. The Fuel Pump Pressure Sensor, Oil Pressure Sensor, and Manifold Pressure Sensor are shown in Figure 34. The Fuel Rail Pressure Sensor is shown in Figure 37 and the Induction Delta Pressure Sensor is shown in Figure 38.</p> <p>Disconnect:</p> <ol style="list-style-type: none"> 1. Pull or pry up on the front of the locking tab (Figure 12) to release it from the locking feature on the sensor and pull the wiring harness connector from the sensor (Figure 13).
Oil Pressure Sensor	OIL-P	
Manifold Pressure Sensor	MAP	<p>Connect:</p> <ol style="list-style-type: none"> 1. Install the wiring harness connector onto the sensor and press firmly until you hear the hinged locking tab click in place.

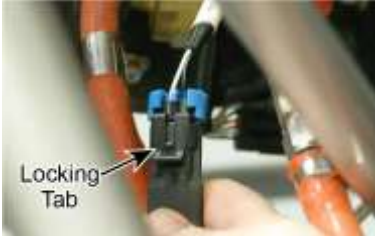


**Table 2 (Cont.)
Wiring Harness Connector Guidelines**

Sensor Name	Abbr.	Guidelines for Disconnecting and Connecting
Cylinder Head Temperature Sensor	CHT-	<div style="display: flex; justify-content: space-around;"> <div style="text-align: center;">  <p>Figure 14 CHT and EGT Connectors</p> </div> <div style="text-align: center;">  <p>Figure 15 EGT Connector Separated</p> </div> </div> <p>The Cylinder Head Temperature Sensor connectors and the Exhaust Gas Temperature Sensor connectors are attached, with cap screws to brackets on either side of the engine (Figure 36).</p>
Exhaust Gas Temperature Sensor	EGT-	<p>Disconnect:</p> <ol style="list-style-type: none"> 1. Remove the cap screw (Figure 14) from the female part of the connector on the wiring harness side. 2. Disconnect the wiring harness side of the connector from the sensor side of the connector (Figure 15). <p>Connect:</p> <ol style="list-style-type: none"> 1. Connect the wiring harness side of the connector to the sensor side of the connector. 2. Install the cap screw through the connector to hold the connector securely.
Turbine Inlet Temperature Sensor	TIT	<div style="display: flex; justify-content: space-around;"> <div style="text-align: center;">  <p>Figure 16 TIT Connector</p> </div> <div style="text-align: center;">  <p>Figure 17 TIT Connector Separated</p> </div> </div> <p>The Turbine Inlet Temperature Sensor connector (Figure 36) is the same type of connector as the Cylinder Head Temperature Sensor connectors and the Exhaust Gas Temperature Sensor connectors except it is not attached to a bracket. The two parts of the connector are secured with a cable tie through the holes in each part of the connector.</p> <p>Disconnect:</p> <ol style="list-style-type: none"> 1. Cut, remove, and discard the cable tie (Figure 16) from the connector and separate the two parts of the connector (Figure 17). <p>Connect:</p> <ol style="list-style-type: none"> 1. Connect the wiring harness side of the connector to the sensor side of the connector. 2. Install a cable tie through the holes in each part of the connector to secure the connection.






**Table 2 (Cont.)
Wiring Harness Connector Guidelines**

Sensor Name	Abbr.	Guidelines for Disconnecting and Connecting
Knock Sensor	KNOCK-	<div style="display: flex; justify-content: space-around;">    </div> <p>Figure 18 Hinged Locking Tab</p> <p>Figure 19 Press the Rear of the Hinged Locking Tab</p> <p>Figure 20 Connector Removed from the Knock Sensor</p> <p>The wiring harness connectors for the Knock Sensors (Figure 18) connect directly to each sensor, located on all six cylinders (Figure 35).</p> <p>Disconnect:</p> <ol style="list-style-type: none"> 1. Press the rear of the hinged locking tab (Figure 19) to release it from the locking feature on the sensor and pull the wiring harness connector from the sensor (Figure 20). <p>Connect:</p> <ol style="list-style-type: none"> 1. Insert the wiring harness connector into the sensor and press firmly until you hear the hinged locking tab click in place.
Primary Induction Air Deck Pressure Sensor	DECK-P-P	<div style="display: flex; justify-content: space-around;">   </div> <p>Figure 21 Primary and Secondary Induction Deck Pressure Sensors</p> <p>Figure 22 Wiring Harness Connector Removed from Induction Deck Pressure Sensor</p> <p>Pressure sensor connectors have a single locking tab on the wiring harness connector. The Primary and Secondary Induction Deck Pressure Sensors (Figure 34) are located on the pipe attached to the inlet of the throttle body. The Primary and Secondary Compressor Inlet Pressure Sensors (Figure 34) location is determined by the airframe manufacturer.</p> <p>Disconnect:</p> <ol style="list-style-type: none"> 1. Pull or pry up on the front of the locking tab (Figure 21) to release it from the locking feature on the sensor and pull the wiring harness connector from the sensor (Figure 22). <p>Connect:</p> <ol style="list-style-type: none"> 1. Install the wiring harness connector onto the sensor and press firmly until you hear the hinged locking tab click in place.
Secondary Induction Air Deck Pressure Sensor	DECK-P-S	
Primary Compressor Inlet Pressure Sensor	CIP-P	
Secondary Compressor Inlet Pressure Sensor	CIP-S	

**Table 2 (Cont.)
Wiring Harness Connector Guidelines**

Sensor Name	Abbr.	Guidelines for Disconnecting and Connecting
Induction Air Deck Temperature	DECK-T	 
Primary Induction Air Manifold Temperature Sensor	MAT-P	<p align="center">Figure 23 Induction Air Deck Temperature Sensor Connector</p> <p align="center">Figure 24 Induction Air Deck Temperature Sensor Connector Separated</p> <p>The Induction Air Temperature Sensor connectors have a single locking tab on the wiring harness connector. The Induction Air Deck Temperature Sensor (Figure 34) is mounted in the Y-pipe attached to the inlet of the throttle body. The Primary Induction Air Manifold Temperature Sensor (Figure 34) is located on the right side of the induction system. The Secondary Induction Air Manifold Temperature Sensor (Figure 34) is located on the left side of the induction system.</p>
Secondary Induction Air Manifold Temperature Sensor	MAT-S	<p>Disconnect:</p> <ol style="list-style-type: none"> 1. Pull or pry up on the front of the locking tab on the wiring harness side of the connector (Figure 23) to release it from the locking feature on the sensor side of the connector and pull the two parts of the connector apart (Figure 24). <p>Connect:</p> <ol style="list-style-type: none"> 1. Press the two parts of the connector together firmly until you hear the locking tab click in place.
Throttle Position Sensor	TPS	 <p align="center">Figure 25 Throttle Position Sensor Connector</p> <p>The Throttle Position Sensor (Figure 38) is located on the throttle body. The wiring harness connector for the Throttle Position Sensor connects directly to the sensor.</p> <p>Disconnect:</p> <ol style="list-style-type: none"> 1. Pull or pry up on the front of the locking tab on the wiring harness connector (Figure 25) to release it from the locking feature on the sensor and pull the wiring harness connector from the sensor. <p>Connect:</p> <ol style="list-style-type: none"> 1. Insert the wiring harness connector into the sensor and press firmly until you hear the locking tab click in place.

**Table 2 (Cont.)
Wiring Harness Connector Guidelines**

Wiring Harness Connection	Guidelines for Disconnecting and Connecting
<p>Fuel Injector</p>	<div style="display: flex; justify-content: space-around; align-items: flex-start;"> <div style="text-align: center;">  <p>Figure 26 Fuel Injector Connector</p> </div> <div style="text-align: center;">  <p>Figure 27 Locking Slide Feature in the Unlocked Position</p> </div> <div style="text-align: center;">  <p>Figure 28 Wiring Harness Connector Removed from the Fuel Injector</p> </div> </div> <p>The wiring harness is connected to each fuel injector on all six cylinders. The wiring harness connector for the Fuel Injector connects directly to the Fuel Injector.</p> <p>Disconnect:</p> <ol style="list-style-type: none"> 1. Move the green locking slide feature (Figure 26) to the unlocked position (Figure 27). 2. Press the grey release tab (Figure 26) and pull the wiring harness connector up to remove it from the fuel injector (Figure 28). <p>Connect:</p> <ol style="list-style-type: none"> 1. Install the wiring harness connector onto the sensor and press firmly until you hear the locking tab click in place. 2. Move the green locking slide feature (Figure 26) down until you hear it click into place.
<p>Prop Governor</p>	<div style="display: flex; justify-content: space-around; align-items: flex-start;"> <div style="text-align: center;">  <p>Figure 29 Prop Governor Connector</p> </div> <div style="text-align: center;">  <p>Figure 30 Wiring Harness Connector Removed from the Prop Governor</p> </div> </div> <p>The wiring harness connector for the Prop Governor connects directly to the Prop Governor, located on the front left-hand side of the engine.</p> <p>Disconnect:</p> <ol style="list-style-type: none"> 1. Pull or pry up on the front of both locking tabs on the wiring harness connector (Figure 29) to release them from the locking features on the prop governor and pull the wiring harness connector from the prop governor (Figure 30). <p>Connect:</p> <ol style="list-style-type: none"> 1. Insert the wiring harness connector into the prop governor connection and press firmly until you hear the locking tabs click in place.

**Table 2 (Cont.)
Wiring Harness Connector Guidelines**

Wiring Harness Connection	Guidelines for Disconnecting and Connecting
Wastegate Control	<div data-bbox="695 359 1081 611" data-label="Image"> </div> <p align="center">Figure 31 Wastegate Control Connector</p> <p>The wiring harness connector for Wastegate Control is the same type connector as used for the wiring harness connection to the Prop Governor. The wiring harness connector for Wastegate Control connects directly to the Wastegate Solenoid, located on the accessory housing.</p> <p>Disconnect:</p> <ol style="list-style-type: none"> 1. Pull or pry up on the front of both locking tabs (Figure 31) on the wiring harness connector to release them from the locking features on the wastegate solenoid and pull the wiring harness connector from the wastegate solenoid. <p>Connect:</p> <ol style="list-style-type: none"> 1. Insert the wiring harness connector into the wastegate solenoid connection and press firmly until you hear the locking tabs click in place.
Permanent Magnet Alternator	<div data-bbox="451 1100 773 1430" data-label="Image"> </div> <p align="center">Figure 32 Permanent Magnet Alternator Harness Plug</p> <div data-bbox="1013 1100 1321 1430" data-label="Image"> </div> <p align="center">Figure 33 Wiring Harness Plug Removed from the Permanent Magnet Alternator</p> <p>The wiring harness contains a power cable that connects to the Permanent Magnet Alternator (PMA) and supplies power generated by the PMA to the Power Box.</p> <p>Disconnect:</p> <ol style="list-style-type: none"> 1. Turn the collar on the wiring harness plug (Figure 32) counter-clockwise until it releases and pull the wiring harness plug from the PMA (Figure 33). <p>Connect:</p> <ol style="list-style-type: none"> 1. Align the wiring harness plug with the connection on the PMA and turn the collar clockwise to secure the connection.

7. Sensor Replacement Procedures

A. Name, abbreviation, identification (ID) number and replacement procedures for each of the sensors are identified in Table 3. The referenced figures show sensor locations.

⚠ CAUTION USE CAUTION AROUND THE WIRING HARNESS, SENSORS AND ACTUATORS. THEY CAN BE EASILY DAMAGED AND CANNOT BE REPAIRED. IF ANY OF THESE ITEMS ARE DAMAGED, THEY MUST BE REPLACED. IF ONE WIRE BREAKS ON THE WIRING HARNESS, THE COMPLETE HARNESS WILL NEED TO BE REPLACED.

NOTICE: Some of the sensor replacement instructions in Table 3 identify specific torque values for sensors that have fastening hardware to attach the sensor to the wiring harness. For other sensors that have fastening hardware refer to Table II section "Pipe Plugs" Part 1 for the given size of the hardware in the Standard Torque Tables in the latest revision of the *Service Table of Limits - SSP-1776* for applicable torque values. All other sensors are either a band clamp type or bayonet type, which are installed with a quarter turn rotation lock. Make sure the correct wiring harness connector is reconnected to the sensor any time the wiring harness has been disconnected.

Table 3
Sensor Replacement Procedures

Sensor Name	Abbr.	ID	Qty.	Location	Replacement Instructions
Crankshaft Speed Sensor	CRANK	A003	1	Mounted on the accessory housing (Figure 34)	<ol style="list-style-type: none"> 1. Disconnect the harness connector from the sensor per instruction in the "Wiring Harness Connectors" section in this chapter. 2. Remove cable ties and clamps from the sensor lead. 3. Remove and discard the safety wire/cable from the cap screw. 4. Remove the cap screw and washer. 5. Remove the sensor and O-ring from the accessory housing. Disassemble the O-ring. 6. Apply engine oil mixture to the O-ring on the new sensor. 7. Install the new sensor with the O-ring in the accessory housing with the cap screw and washer. Torque the cap screw per the Standard Torque Tables in the latest revision of the <i>Service Table of Limits - SSP-1776</i>. 8. Install new safety wire/cable on the cap screw. 9. Connect the harness connector to the sensor lead per instruction in the "Wiring Harness Connectors" section in this chapter and install cable ties and clamps. 10. Complete an operational ground check.*

**Table 3 (Cont.)
Sensor Replacement Procedures**

Sensor Name	Abbr.	ID	Qty.	Location	Replacement Instructions
Camshaft Speed Sensor	CAM	A004	1	Mounted on the accessory housing (Figure 34)	Same as crankshaft speed sensor.
Oil Temperature Sensor	OIL-T	A026	1	(Figure 34)	<ol style="list-style-type: none"> 1. Disconnect the harness connector from the sensor per instruction in the “Wiring Harness Connectors” section in this chapter. 2. Remove the sensor. 3. Install the new sensor. Torque hardware to 84 to 120 in.-lb. (9.5 to 13 Nm). 4. Connect the harness connector to the sensor per instruction in the “Wiring Harness Connectors” section in this chapter. 5. Complete an operational ground check.*
Manifold Pressure Sensor	MAP	A040	1	Mounted on the crankcase (Figure 34)	<ol style="list-style-type: none"> 1. Disconnect the wiring harness from the sensor per instruction in the “Wiring Harness Connectors” section in this chapter. 2. Remove the sensor from the engine. 3. Install the new sensor. 4. Refer to Standard Torque Tables in the latest revision of the <i>Service Table of Limits - SSP-1776</i> for torque values. 5. Connect the wiring harness to the sensor per instruction in the “Wiring Harness Connectors” section in this chapter. 6. Complete an operational ground check.*

**Table 3 (Cont.)
Sensor Replacement Procedures**

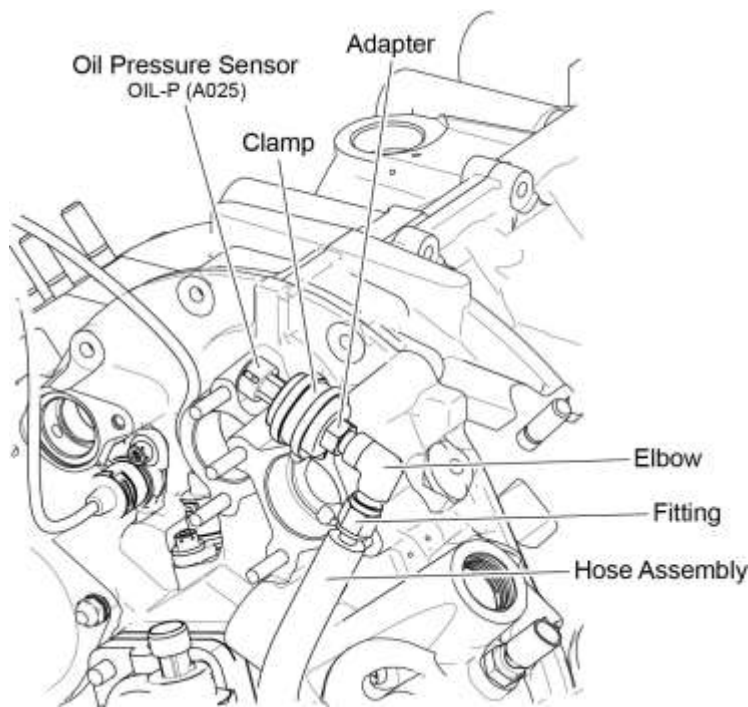
Sensor Name	Abbr.	ID	Qty.	Location	Replacement Instructions
Induction Air Deck Temperature	DECK-T	A041	1	Mounted in the Y-pipe attached to the inlet of the throttle body (Figure 34)	<ol style="list-style-type: none"> 1. Disconnect the harness connector from the sensor per instruction in the “Wiring Harness Connectors” section in this chapter. 2. Remove the sensor from the induction housing. 3. Install the new sensor in the induction housing. 4. Refer to Standard Torque Tables in the latest revision of the <i>Service Table of Limits - SSP-1776</i> for torque values. 5. Connect the harness connector to the sensor per instruction in the “Wiring Harness Connectors” section in this chapter. 6. Complete an operational ground check.*
Primary Induction Air Manifold Temperature Sensor	MAT-P	A035	1	(Figure 34)	<ol style="list-style-type: none"> 1. Disconnect the harness connector from the sensor per instruction in the “Wiring Harness Connectors” section in this chapter. 2. Remove and discard tie-wraps from the fire shield on the sensor lead. 3. Remove the fire sleeve from the sensor lead. 4. Remove the sensor. 5. Install the new sensor. 6. Refer to Standard Torque Tables in the latest revision of the <i>Service Table of Limits - SSP-1776</i> for torque values. 7. Install the fire sleeve on the sensor lead. 8. Install new tie wraps on the fire shield on the sensor lead. 9. Connect the harness connector to the sensor per instruction in the “Wiring Harness Connectors” section in this chapter. 10. Complete an operational ground check.*
Secondary Induction Air Manifold Temperature Sensor	MAT-S	A042	1	Mounted in the induction manifold (Figure 34)	Same as MAT-P procedure.

**Table 3 (Cont.)
Sensor Replacement Procedures**

Sensor Name	Abbr.	ID	Qty.	Location	Replacement Instructions
Cylinder Head Temperature (CHT) Sensor	CHT-1	A087	6	Mounted on the temperature probe port of each cylinder head (Figure 36) NOTICE: Be sure to install the correct CHT sensor in the applicable numbered cylinder	<ol style="list-style-type: none"> Remove the cap screw holding the CHT sensor connector to the harness bracket. Disconnect the harness connector from the sensor per instruction in the “Wiring Harness Connectors” section in this chapter. Remove the sensor from the cylinder head by pushing the locking collar in and turning 1/4 turn counterclockwise. Push the new sensor into the cylinder head and then push the locking collar in. Turn the locking collar 1/4 turn clockwise. Connect the harness connector to the sensor per instruction in the “Wiring Harness Connectors” section in this chapter. Install the cap screw. Torque the cap screw per the Standard Torque Tables in the latest revision of the <i>Service Table of Limits - SSP-1776</i>, for torque values. Complete an operational ground check.*
	CHT-2	A088			
	CHT-3	A089			
	CHT-4	A090			
	CHT-5	A091			
	CHT-6	A092			
Exhaust Gas Temperature (EGT) Sensor	EGT-1	A080	6	Mounted in the exhaust port of each cylinder (Figure 36) NOTICE: Be sure to install the correct EGT sensor in the applicable numbered cylinder	<ol style="list-style-type: none"> Remove the cap screw holding the EGT sensor connector to the harness connector. Disconnect the sensor connector from the harness connector per instruction in the “Wiring Harness Connectors” section in this chapter. Loosen the worm screw of the EGT sensor hose clamp. Remove the EGT sensor from the exhaust manifold. Insert the new EGT sensor in the exhaust manifold. Tighten the worm screw of the EGT sensor hose clamp. Torque the worm screw per the Special Torque Requirements Table in Section V of Part 1 in the latest revision of the <i>Service Table of Limits - SSP-1776</i>. Connect the sensor connector to the harness connector per instruction in the “Wiring Harness Connectors” section in this chapter. Install and torque the cap screw per Standard Torque Tables in the latest revision of the <i>Service Table of Limits - SSP-1776</i>. Complete an operational ground check.*
	EGT-2	A081			
	EGT-3	A082			
	EGT-4	A083			
	EGT-5	A084			
	EGT-6	A085			

**Table 3 (Cont.)
Sensor Replacement Procedures**

Sensor Name	Abbr.	ID	Qty.	Location	Replacement Instructions
Turbine Inlet Temperature Sensor	TIT	A093	1	Mounted in the housing of the exhaust collector (Figure 36)	<ol style="list-style-type: none"> 1. Disconnect the harness connector from the sensor per instruction in the “Wiring Harness Connectors” section in this chapter. 2. Remove the sensor from the exhaust collector. 3. Install the new sensor in the exhaust collector. 4. Refer to the Standard Torque Tables in latest revision of the <i>Service Table of Limits - SSP-1776</i>, for torque values. 5. Connect the harness connector to the sensor per instruction in the “Wiring Harness Connectors” section in this chapter. 6. Complete an operational ground check.*
Oil Pressure Sensor	OIL-P	A025	1	Remote mounted at top of accessory housing (Figure 34)	<ol style="list-style-type: none"> 1. Disconnect the harness connector from the sensor per instruction in the “Wiring Harness Connectors” section in this chapter. 2. Disconnect the hose assembly fitting from the elbow. 3. Loosen the clamp and remove the sensor from the clamp. 4. Install the new sensor with the clamp. Tighten the clamp per Standard Torque Tables in the latest revision of the <i>Service Table of Limits - SSP-1776</i>. 5. Connect the hose assembly fitting to the elbow. Torque the hose assembly fitting per Standard Torque Tables in the latest revision of the <i>Service Table of Limits - SSP-1776</i>. 6. Torque the sensor clamp per the Standard Torque Tables in the latest revision of the <i>Service Table of Limits - SSP-1776</i>. 7. Connect the harness connector to the sensor per instruction in the “Wiring Harness Connectors” section in this chapter. 8. Complete an operational ground check.*



Oil Pressure Sensor Detail from Figure 34

**Table 3 (Cont.)
Sensor Replacement Procedures**

Sensor Name	Abbr.	ID	Qty.	Location	Replacement Instructions
Fuel Pump Pressure Sensor	FPP	A014	1	Mounted in a fitting at the outlet of the engine driven mechanical fuel pump and before the engine filter (Figure 34)	<ol style="list-style-type: none"> 1. Disconnect the harness connector from the sensor per instruction in the “Wiring Harness Connectors” section in this chapter. 2. Remove the sensor from the fitting. 3. Install the new sensor in the fitting. 4. Refer to Standard Torque Tables in the latest revision of the <i>Service Table of Limits - SSP-1776</i> for torque values. 5. Connect the harness connector to the sensor per instruction in the “Wiring Harness Connectors” section in this chapter. 6. Complete an operational ground check.*
Fuel (Rail) Pressure Sensor	FUEL-P	A013	1	Mounted on the fuel manifold immediately before the fuel pressure regulator. NOTICE: Fuel manifold is mounted behind the coil box on top of the engine crankcase. (Figure 37)	<ol style="list-style-type: none"> 1. Ensure the fuel hoses are depressurized by loosening the cap on the fuel pressure regulator bleed port. 2. Disconnect the harness connector from the sensor per instruction in the “Wiring Harness Connectors” section in this chapter. 3. Remove the sensor from the pressure regulator manifold. 4. Install the new sensor in the pressure regulator manifold. 5. Refer to Standard Torque Tables in the latest revision of the <i>Service Table of Limits - SSP-1776</i>, for torque values. 6. Torque the cap on the bleed fitting to 84 to 120 in.-lb. (9.5 to 13 Nm). 7. Connect the harness connector to the sensor per instruction in the “Wiring Harness Connectors” section in this chapter. 8. Complete an operational ground check.*

**Table 3 (Cont.)
Sensor Replacement Procedures**

Sensor Name	Abbr.	ID	Qty.	Location	Replacement Instructions
Fuel Temperature Sensor	FUEL-T	A012	1	Mounted in the fuel manifold (Figure 37)	<ol style="list-style-type: none"> 1. Ensure fuel hoses are depressurized by loosening the cap on the fuel pressure regulator bleed port. 2. Disconnect the harness connector from the sensor per instruction in the “Wiring Harness Connectors” section in this chapter. 3. Remove the sensor from the pressure regulator manifold. 4. Install the new sensor in the pressure regulator manifold. 5. Refer to Standard Torque Tables in the latest revision of the <i>Service Table of Limits - SSP-1776</i> for torque values. 6. Torque the cap on the bleed fitting to 84 to 120 in.-lb. (9.5 to 13 Nm). 7. Connect the harness connector to the sensor per instruction in the “Wiring Harness Connectors” section in this chapter. 8. Complete an operational ground check.*
Primary Induction Air Deck Pressure Sensor	DECK-P-P	A045	1	Mounted on the pipe attached to the inlet of the throttle body (Figure 34)	<ol style="list-style-type: none"> 1. Disconnect the harness connector from the sensor per instruction in the “Wiring Harness Connectors” section in this chapter. 2. Cut and remove the safety wire from the cap screws. 3. Remove the cap screws and washers. 4. Remove the sensor retaining block. 5. Remove the sensor from manifold. 6. Install the new sensor in the manifold. 7. Install the sensor and retaining block with cap screws and washers. Tighten the cap screws. 8. Refer to Standard Torque Tables in the latest revision of the <i>Service Table of Limits - SSP-1776</i> for torque values. 9. Safety wire/cable the cap screws. 10. Connect the harness connector to the sensor per instruction in the “Wiring Harness Connectors” section in this chapter. 11. Complete an operational ground check.*

**Table 3 (Cont.)
Sensor Replacement Procedures**

Sensor Name	Abbr.	ID	Qty.	Location	Replacement Instructions
Secondary Induction Air Deck Pressure Sensor	DECK-P-S	A036	1	Mounted on the pipe attached to the inlet of the throttle body (Figure 34)	Same as DECK-P-P procedure.
Primary Compressor Inlet Pressure Sensor	CIP-P	A037	1	Mounting to be determined by the airframe manufacturer**	Refer to the Airframe Maintenance Manual for Procedure.
Secondary Compressor Inlet Pressure Sensor	CIP-S	A038	1	Mounting to be determined by the airframe manufacturer**	Refer to the Airframe Maintenance Manual for Procedure.
Knock Sensor	KNOCK-1	A016	6	Mounted on each cylinder head (Figure 35) NOTICE: Be sure to install the knock sensor in the correct numbered cylinder	1. Disconnect the harness connector from the sensor per instruction in the “Wiring Harness Connectors” section in this chapter. 2. Remove the bolt, lock washer, and washers securing the sensor to the cylinder and remove the sensor. Discard the lock washers. 3. Install the new sensor with a bolt, new lock washer, and washer. 4. Torque the bolt to 120 in.-lb. (13 Nm). 5. Connect the harness connector to the sensor per instruction in the “Wiring Harness Connectors” section in this chapter. 6. Complete an operational ground check.*
	KNOCK-2	A015			
	KNOCK-3	A018			
	KNOCK-4	A019			
	KNOCK-5	A020			
	KNOCK-6	A017			
Throttle Position Sensor	TPS	A043	2	Mounted to the throttle body (Figure 38)	To replace this sensor, replace the throttle body as per Chapter 73-20.
Induction Delta Pressure Sensor	DPS	A039	1	Mounted to the throttle body (Figure 38)	To replace this sensor, replace the throttle body as per Chapter 73-20.
* Per Chapter 72-00 ** Connected to the airframe induction system after the aircraft air cleaner(s) and before the turbocharger compressor inlets.					

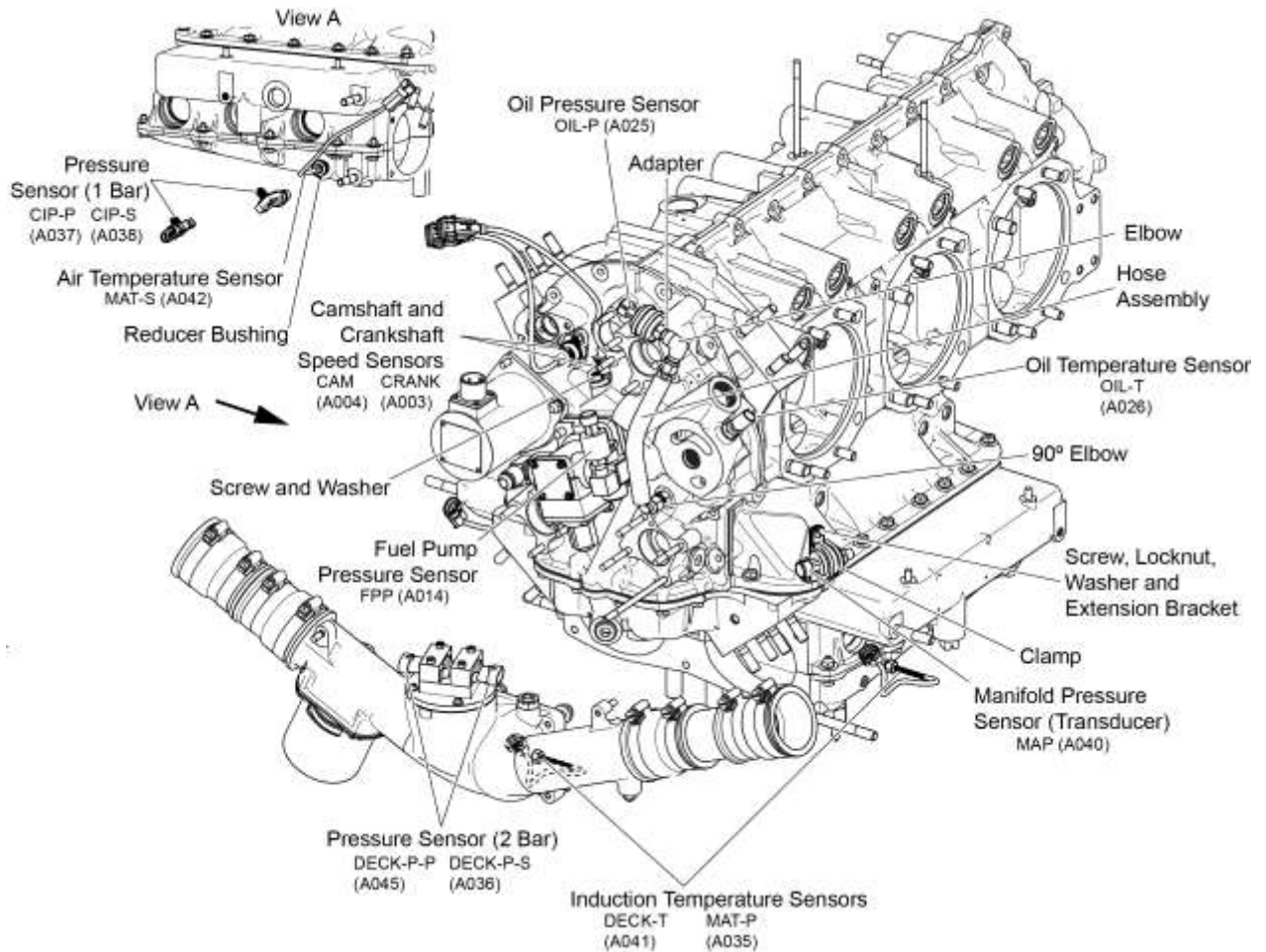


Figure 34
Sensor Locations (Accessory Housing View)

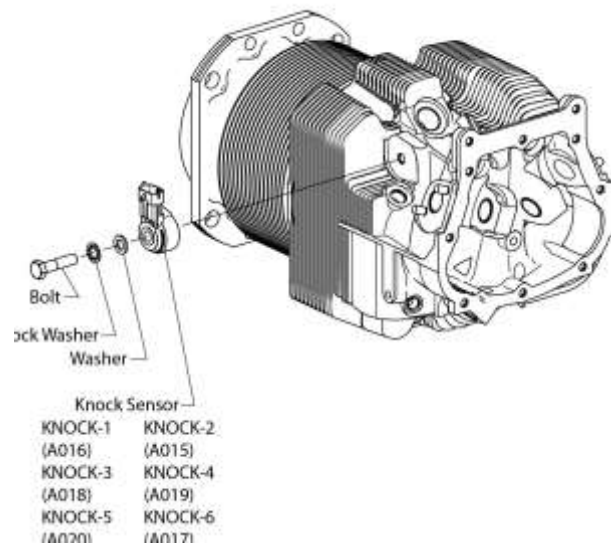


Figure 35
Knock Sensor

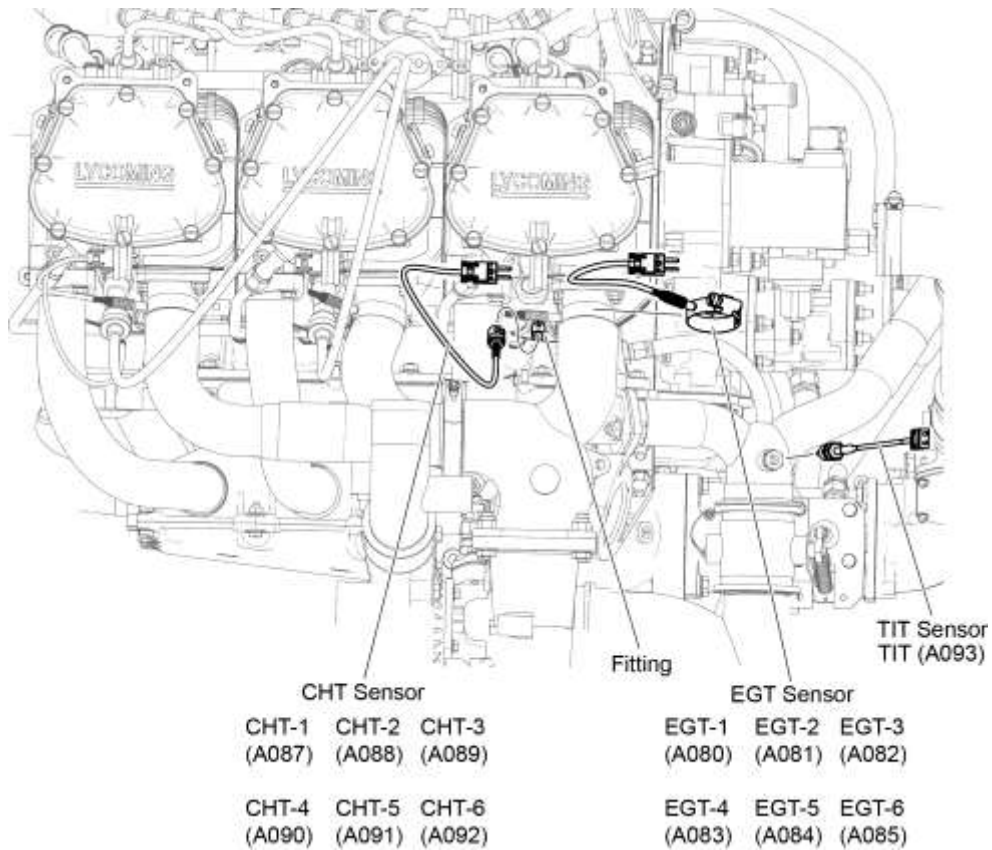


Figure 36
Sensors Locations (Left View)

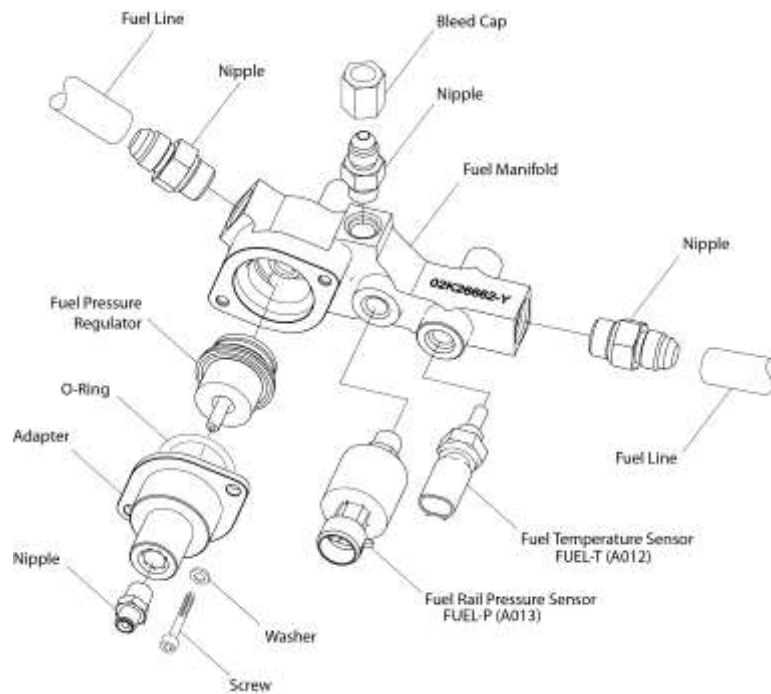


Figure 37
Fuel Injector Rail Pressure Sensor and Fuel Temperature Sensor

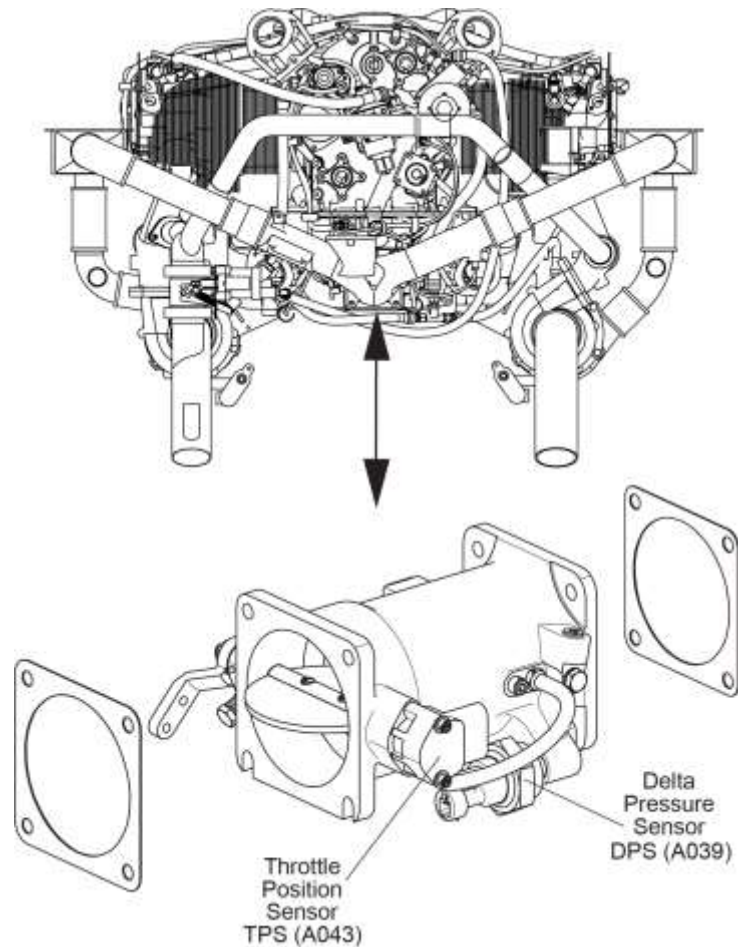


Figure 38
Sensors on the Throttle Body

8. Engine-to-Firewall Wiring Harness Removal

⚠ CAUTION ANY TIME AN ELECTRICAL CONNECTOR IS DISCONNECTED, INSTALL A CAP ON THE CONNECTOR TO PREVENT DAMAGE OR CONTAMINATION FROM FOD, CHEMICALS, OR FLUIDS.

NO EECS PARTS OR HARNESS CAN BE INTERCHANGED BETWEEN ENGINES UNLESS AGREED UPON BY LYCOMING ENGINES.

NOTICE: This procedure can be done with the engine installed in the airframe.

- A. Disconnect the battery.
- B. Pull the circuit breaker to disconnect power to the EECS/ECU.

⚠ CAUTION USE CAUTION AROUND THE WIRING HARNESS, SENSORS AND ACTUATORS. THEY CAN BE EASILY DAMAGED AND CANNOT BE REPAIRED. IF ANY OF THESE ITEMS ARE DAMAGED, THEY MUST BE REPLACED. IF ONE WIRE BREAKS ON THE WIRING HARNESS, THE COMPLETE HARNESS WILL NEED TO BE REPLACED.

- C. For reference on assembly, identify by label each of the sensors on the engine.

- D. Disconnect the engine-to-firewall wiring harness (Figure 39) from the airframe interface wiring harness at the four firewall connectors.
- E. Disconnect the two harness plugs A037-P (CIP-P) and A038-P (CIP-S) from the pressure sensors (Figure 34) installed in the induction system between the airframe induction air filter and the turbocharger compressor inlets.

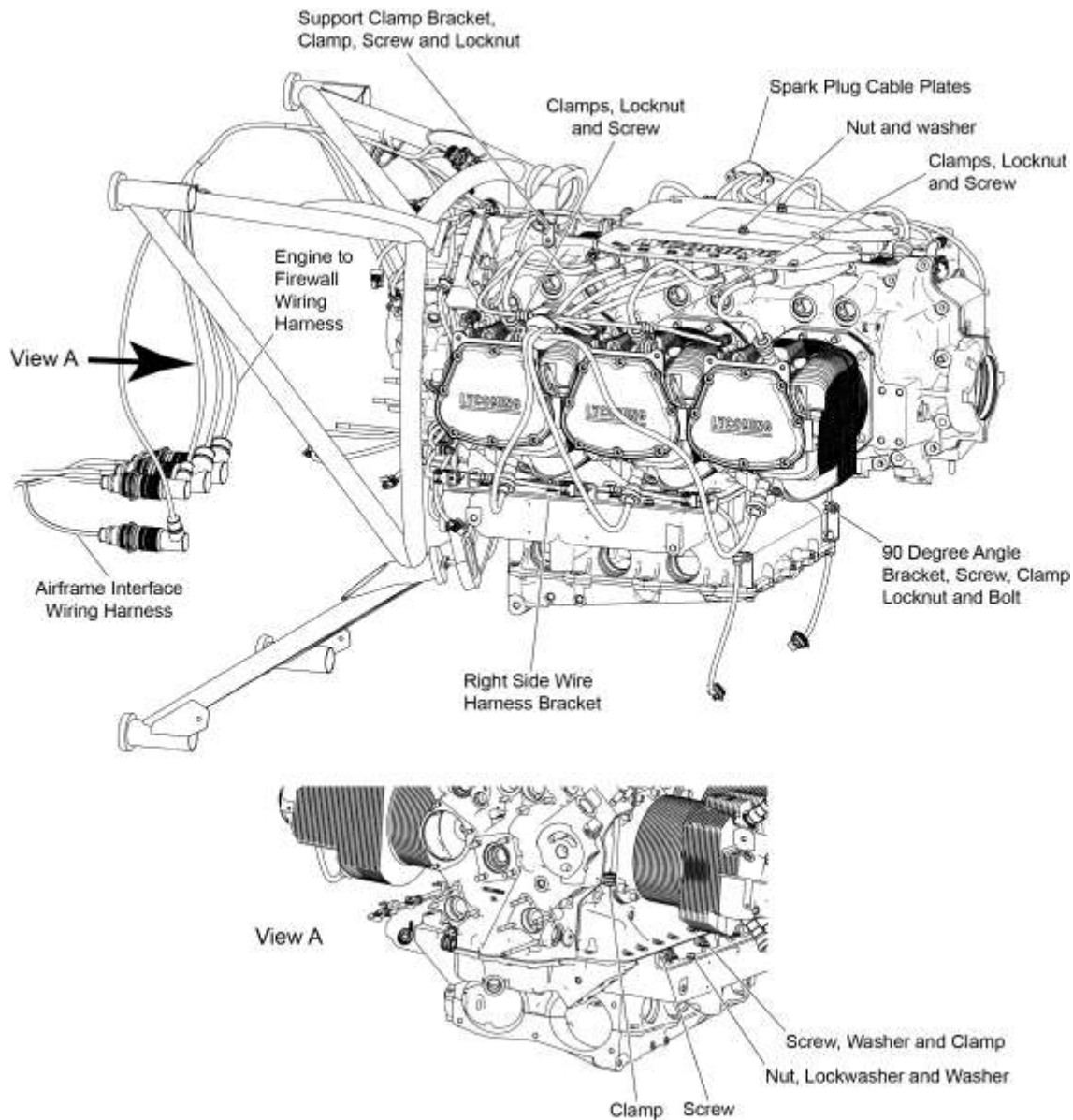


Figure 39
Wiring Harnesses - Top Right Front

NOTICE: Refer to Table 2 - Wiring Harness Connector Guidelines, in this chapter, when disconnecting the wiring harness from the engine sensors.

- F. Disconnect the connector A093-P (TIT) (Figure 36) from the sensor for the turbocharger inlet on the left side (exhaust bypass valve side) of the engine.
- G. Remove the coil box cover. Refer to the section "Coil Box Access" in Chapter 74-30.

- H. Identify and remove each engine-to-firewall wiring harness connector from its sensor, actuator, and coil.
- I. Remove the fasteners from the left and right side harness brackets. Remove the brackets.
- ⚠ CAUTION** THE HARNESS HAS DIFFERENT DIAMETERS AT VARIOUS LOCATIONS. CLAMPS ARE SIZED SPECIFICALLY FOR EACH AREA ON THE HARNESS. KEEP THE CLAMPS ON THE HARNESS TO BE REMOVED.
- J. Remove the harness from left and right side harness brackets. Allow the clamps to remain on the harness.
- K. If a harness is to be replaced with a new harness, identify the location of each clamp (Figures 39 and 40) by a label on the clamp.
- L. Once the harness is disconnected from all attachments, remove the engine-to-firewall wiring harness from the engine.

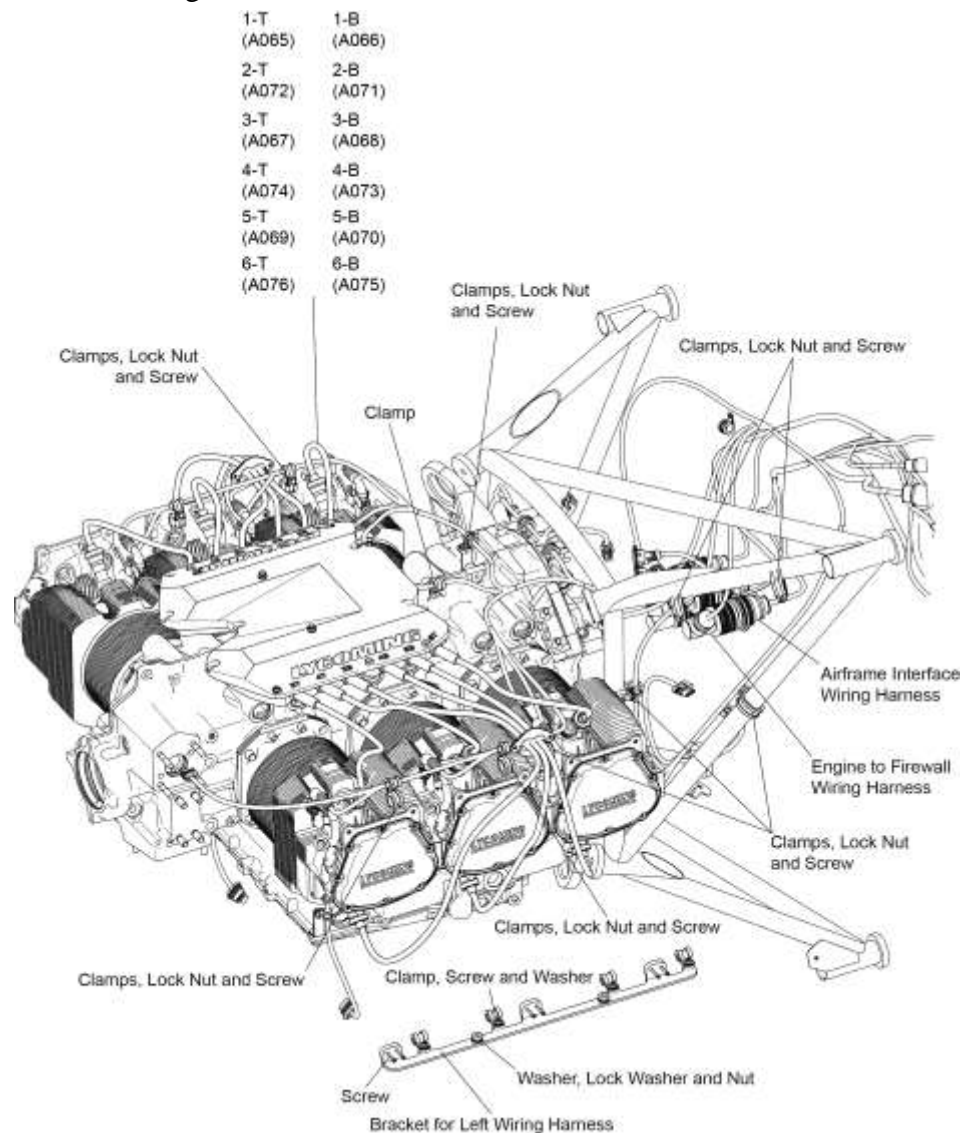


Figure 40
Wiring Harnesses - Top Left Front

9. Engine-to-Firewall Wiring Harness Installation

⚠ CAUTION USE CAUTION AROUND THE WIRING HARNESS, SENSORS AND ACTUATORS. THEY CAN BE EASILY DAMAGED AND CANNOT BE REPAIRED. IF ANY OF THESE ITEMS ARE DAMAGED, THEY MUST BE REPLACED. IF ONE WIRE BREAKS ON THE WIRING HARNESS, THE COMPLETE HARNESS WILL NEED TO BE REPLACED.

NO EECS PARTS OR HARNESS CAN BE INTERCHANGED BETWEEN ENGINES UNLESS AGREED UPON BY LYCOMING ENGINES.

NOTICE: All the plugs on the wiring harness are uniquely keyed and must be in the correct orientation for the plug to install correctly in the receptacle. Refer to Appendix D in the *TEO-540-A1A Engine Installation and Operation Manual*.

NOTICE: This procedure can be done with the engine installed in the airframe.
Remove protective caps before making any wiring harness connections.

- A. Ensure power is off.
- B. Ensure EECS/ECU breaker is pulled to disconnect power.
- C. Put the engine-to-firewall wiring harness on the engine as shown in Figures 39 and 40.

⚠ CAUTION THE HARNESS HAS DIFFERENT DIAMETERS AT VARIOUS LOCATIONS. CLAMPS ARE SIZED SPECIFICALLY FOR EACH AREA ON THE HARNESS. IF A NEW HARNESS IS TO BE INSTALLED, REFER TO THE LOCATION OF EACH CLAMP ON THE OLD HARNESS FOR INSTALLATION ON THE NEW HARNESS. ALL OF THE CLAMPS MUST BE INSTALLED IN THE CORRECT LOCATION ONE AT A TIME.

- D. If a new harness is being installed, remove the screws, lock nuts, bolts and screws, and labeled clamps from the old wiring harness one at a time. Discard the lock nuts.
- E. Install the left and right side harness brackets (Figures 39 and 40) on respective sides of the engine-to-firewall harness with the attaching screws, washers, and new lock nuts. Torque the hardware as per the Standard Torque Tables in the latest revision of the *Service Table of Limits - SSP-1776*.

⚠ CAUTION USE CAUTION WHEN TOUCHING THE SENSORS AND ACTUATORS. THEY CAN BE EASILY DAMAGED. NONE CAN BE REPAIRED. IF ANY OF THESE ITEMS ARE DAMAGED, THEY MUST BE REPLACED.

- G. Install each harness actuator connector in its corresponding actuator connection.

NOTICE: Refer to "Sensor Replacement Procedures" in this chapter to ensure the correct wiring harness lead is connected to its corresponding sensor.

Refer to Table 2 - Wiring Harness Connector Guidelines, in this chapter, when connecting the wiring harness to the engine sensors.

- H. Install each harness sensor connection in its corresponding sensor connection.
- I. Install each harness coil connection in its corresponding coil connection.
- J. Install the coil box cover. Refer to the section "Coil Box Access" in Chapter 74-30.

- K. For the remainder of the engine-to-firewall wiring harness installation, refer to the "Engine Installation" chapter and Appendix D in the *TEO-540-A1A Engine Installation and Operation Manual* for instructions to install the engine-to-firewall harness.
- L. Reset the EECS/ECU circuit breaker.
- M. Complete the operational ground check in Chapter 72-00.

10. Airframe Interface Wiring Harness Removal

NOTICE: Refer to latest revision of the Aircraft Maintenance Manual for aircraft specific removal and installation details.

- A. Disconnect the battery.
- B. Pull the circuit breaker to disconnect power to the EECS/ECU.

CAUTION USE CAUTION AROUND THE WIRING HARNESS. THE WIRING HARNESS CAN BE EASILY DAMAGED AND CANNOT BE REPAIRED. IF ONE WIRE BREAKS ON THE WIRING HARNESS, THE COMPLETE HARNESS WILL NEED TO BE REPLACED.

NO EECS PARTS OR HARNESS CAN BE INTERCHANGED BETWEEN ENGINES UNLESS AGREED UPON BY LYCOMING ENGINES.

- C. Refer to wiring diagram (T-11327-Y) in Appendix B of this manual. Disconnect the harness plug A001-P1 from the ECU large (100-pin) receptacle identified as PRI.
- D. Disconnect harness plug A001-P3 from the ECU small (37-pin) receptacle identified as PRI.
- E. Disconnect harness plug A001-P2 from the ECU large (100-pin) receptacle identified as SEC.
- F. Disconnect harness plug A001-P4 from the ECU small (37-pin) receptacle identified as SEC.
- G. Disconnect harness plug A002-P1 from the power box receptacle identified as PRI.
- H. Disconnect harness plug A002-P2 from the power box receptacle identified as SEC.
- I. Disconnect harness plug AF-P1 from the airframe interface wiring harness connector.
- J. Disconnect harness plug AF-P2 from the airframe interface wiring harness connector.
- K. On the engine side of the firewall, remove the safety wire and jam nuts from bulkhead connectors FW1-J1, FW1-J2, FW2-J1, and FW2-J2.

CAUTION THE HARNESS HAS DIFFERENT DIAMETERS AT VARIOUS LOCATIONS. CLAMPS ARE SIZED SPECIFICALLY FOR EACH AREA ON THE HARNESS. IF THE HARNESS IS NOT TO BE REPLACED WITH A NEW HARNESS, KEEP THE CLAMPS ON THE HARNESS TO BE REMOVED.

- L. Remove the harness from left and right side harness brackets. Allow the clamps to remain on the harness.
- M. If the harness is to be replaced with a new harness, identify the location of each clamp by a label on the clamp.
- N. Once the harness is disconnected from all attachments, remove the fuselage wiring harness from the aircraft.

11. Airframe Interface Wiring Harness Installation

⚠ CAUTION USE CAUTION AROUND THE WIRING HARNESS. THE WIRING HARNESS CAN BE EASILY DAMAGED AND CANNOT BE REPAIRED. IF ONE WIRE BREAKS ON THE WIRING HARNESS, THE COMPLETE HARNESS WILL NEED TO BE REPLACED.

NO EECS PARTS OR HARNESS CAN BE INTERCHANGED BETWEEN ENGINES UNLESS AGREED UPON BY LYCOMING ENGINES.

NOTICE: All the plugs on the wiring harness are uniquely keyed and must be in the correct orientation for the plug to install correctly in the receptacle. Refer to Appendix D in the *TEO-540-A1A Engine Installation and Operation Manual*.

This procedure can be done with the engine installed in the airframe.

Refer to latest revision of the Aircraft Maintenance Manual for aircraft specific removal and installation details.

- A. Refer to the wiring diagram.
- B. Ensure power is off.
- C. Ensure EECS/ECU breaker is pulled.

⚠ CAUTION THE HARNESS HAS DIFFERENT DIAMETERS AT VARIOUS LOCATIONS. CLAMPS ARE SIZED SPECIFICALLY FOR EACH AREA ON THE HARNESS. IF A NEW HARNESS IS TO BE INSTALLED, REFER TO THE LOCATION OF EACH CLAMP ON THE OLD HARNESS FOR INSTALLATION ON THE NEW HARNESS. ALL OF THE CLAMPS MUST BE INSTALLED IN THE CORRECT LOCATION ONE AT A TIME.


- D. If a new fuselage harness is to be installed, remove each clamp and attaching hardware.
- E. Install the harness with same routing as the removed harness.
- F. Secure all clamps on the harness using previous removed screws/bolts, washers, nuts and new lock washers, in same identified location they were removed

NOTICE: The threaded plugs must be tightened until the red colored band of the receptacle cannot be seen from the side of the connection.

- G. Ensure O-rings are on connectors, and install connections FW1-J1, FW1-J2, FW2-J1, and FW2-J2 into the correct holes in firewall.
- H. On the engine side of the firewall, install jam nuts on connectors FW1-J1, FW1-J2, FW2-J1, and FW2-J2, and safety wire jamb nuts.
- I. Attach the following connectors to the ECU:
 - (1) A001-P1 to PRI (100-pin).
 - (2) A001-P2 to SEC (100-pin).
 - (3) A001-P3 to PRI (37-pin).
 - (4) A001-P4 to SEC (37-pin).

- J. Attach the following connectors to the power box receptacle:
 - (1) A002-P1 to PRI.
 - (2) A002-P2 to SEC.
 - K. Connect harness plug AF-P1 to the airframe interface wiring harness connector.
 - L. Connect harness plug AF-P2 to the airframe interface wiring harness connector.
 - M. Reconnect the battery and reset the EECS/ECU circuit breaker.
 - N. Complete the operational ground check in Chapter 72-00.
12. ECU Removal
- NOTICE:** The Engine Control Unit (ECU) configuration is unique for each engine is not to be interchanged and installed on other engines.
- A. Disconnect the battery.
 - B. Pull the EECS/ECU breaker to disconnect power to the EECS.
 - C. Disconnect the airframe interface harness plug from the ECU large (100-pin) receptacle identified as PRI. Refer to Appendix D in the *TEO-540-A1A Engine Installation and Operation Manual*.
 - D. Disconnect the airframe interface harness plug from the ECU small (37-pin) receptacle identified as PRI.
 - E. Disconnect the airframe interface harness plug from the ECU large (100-pin) receptacle identified as SEC.
 - F. Disconnect the airframe interface harness plug from the ECU small (37-pin) receptacle identified as SEC.
 - G. Remove the ECU in accordance with instructions in the airframe maintenance manual.

13. ECU Installation

 **CAUTION** THE ECU HAS A SPECIFIC CONFIGURATION FOR EACH ENGINE AND THE AIRFRAME. THE ECU AND ENGINE HAVE FACTORY-DESIGNATED SERIAL NUMBERS THAT GO TOGETHER. MAKE SURE THE SERIAL NUMBER FOR THE ECU AGREES WITH THE SERIAL NUMBER ON THE ENGINE. IF THE SERIAL NUMBERS DO NOT AGREE, DO NOT INSTALL THE ECU. CONTACT LYCOMING ENGINES IMMEDIATELY.

- NOTICE:** The ECU configuration is unique for each engine and is not to be installed for any other engine unless a new configuration is loaded.
- A. Install the ECU in accordance with instructions in the airframe maintenance manual.
 - B. Connect the appropriate airframe interface harness plug to ECU large (100-pin) receptacle identified as PRI. Refer to Appendix D in the *TEO-540-A1A Engine Installation and Operation Manual*.
 - C. Connect the appropriate airframe interface harness plug A001-P2 to ECU large (100-pin) receptacle identified as SEC.
 - D. Connect the appropriate airframe interface harness plug A001-P3 to ECU small (37-pin) receptacle identified as PRI.

- E. Connect the appropriate airframe interface harness plug A001-P4 to ECU small (37-pin) receptacle identified as SEC.
- F. Reset the EECS/ECU circuit breaker.
- G. Connect the battery.
- H. Complete the operational ground check in Chapter 72-00.

14. Power Box Removal

- A. Disconnect the battery.
- B. Pull the circuit breaker to disconnect power to the EECS/ECU.
- C. Disconnect the airframe interface harness plug A002-P1 from the power box receptacle identified as PRI. Refer to Appendix D in the *TEO-540-A1A Engine Installation and Operation Manual*.
- D. Disconnect the airframe interface harness plug A002-P2 from the power box receptacle identified as SEC.
- E. Remove the power box in accordance with instructions in the airframe maintenance manual.

15. Power Box Installation

- A. Install the power box in accordance with instructions in the airframe maintenance manual.
- B. Connect the appropriate airframe interface harness plug A002-P1 to the power box receptacle identified as PRI. Refer to Appendix D in the *TEO-540-A1A Engine Installation and Operation Manual*.
- C. Connect the appropriate airframe interface harness plug A002-P2 to the power box) receptacle identified as SEC.
- D. Reconnect the battery and reset the EECS/ECU circuit breaker.
- E. Complete the operational ground check in Chapter 72-00.

16. Permanent Magnet Alternator (PMA) Replacement

NOTICE: The PMA does not have regularly scheduled maintenance procedures. The PMA is not field repairable. It can only be replaced.

A. PMA Removal

- (1) Remove the three nuts, lock washers, and washers (Figure 41) that attach the PMA to the accessory housing. Discard the lock washers.
- (2) Remove the PMA from the accessory housing.
- (3) Remove and discard the O-ring from the PMA mating surface.

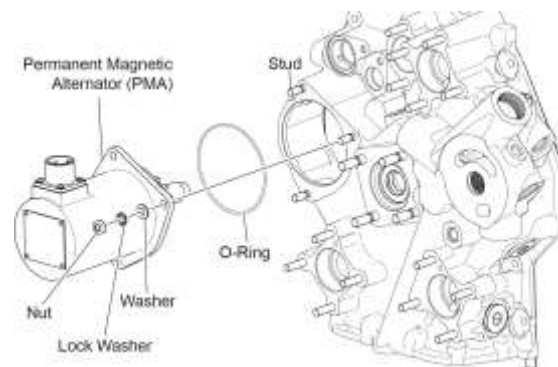


Figure 41
Permanent Magnet Alternator

B. PMA Installation

- (1) Remove the shaft from the PMA (Figure 43).
- (2) Lubricate the counter-bore inside the PMA body with engine oil (Figure 42).

⚠ CAUTION MAGNETIC PULL CAN CAUSE THE SHAFT TO BE DAMAGED DURING INSTALLATION. HOLD THE SHAFT FIRMLY DURING INSTALLATION.

- (3) Re-install the shaft in the PMA body (Figure 43).



Figure 42

Counter-Bore Inside the PMA Body



Figure 43

Shaft in PMA Body



Figure 44

Shaft Bore in the Crankcase

NOTICE: Engine oil is permissible on shaft gear.

- (4) Fill the internals of the PMA shaft with clean engine oil.
- (5) Lubricate the PMA shaft bore in the crankcase with clean engine oil (Figure 44).
- (6) Install a new O-ring (Figure 41) in the groove of the PMA mating surface.
- (7) Align the holes in the PMA flange with the three studs in the accessory housing as shown in Figure 41.
- (8) Install the PMA by meshing the PMA gear with the idler gear in the accessory housing.
- (9) Attach the PMA to the accessory housing with the three nuts, new lock washers, and washers (Figure 41).
- (10) Torque the nuts in incremental steps to a final torque of 96 in.-lb. (11 Nm).

17. Starter Replacement

A. Starter Removal

- (1) Disconnect the battery.
- (2) Remove electrical leads from the starter. Refer to the airframe manufacturer's manual.
- (3) Remove the bolt, lock washer, and washer from the starter (Figure 45). Discard the lock washer.
- (4) Hold the starter and remove the three nuts, lock washers, and washers from the studs on the mounting face for the starter. Discard the lock washers.
- (5) Remove the starter from the studs on the engine.

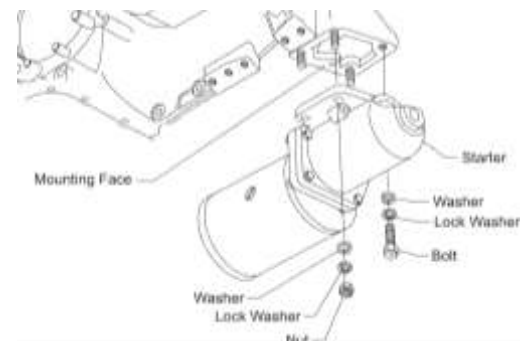


Figure 45
Starter Detail

- (4) Remove the alternator and alternator belts (Figure 48).

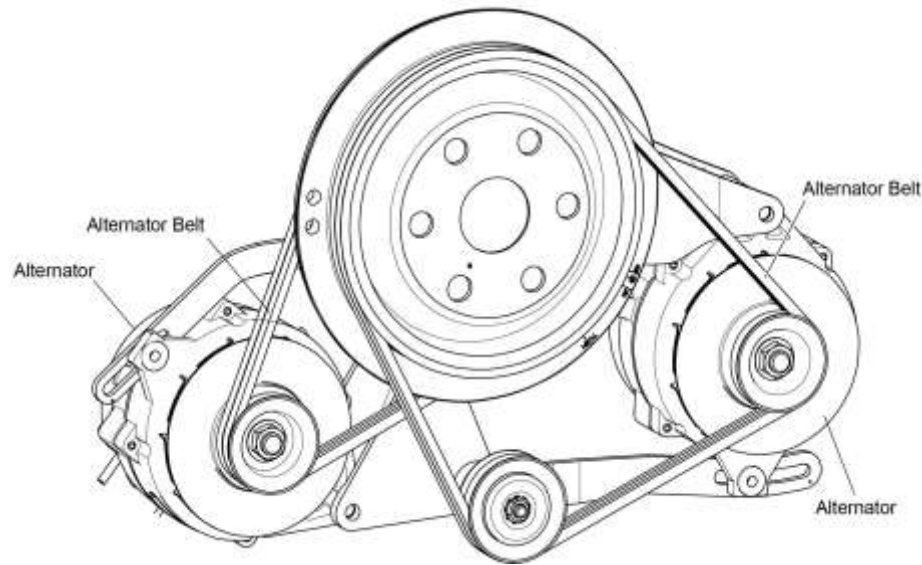


Figure 48
Alternators and Alternator Belts

B. To remove the right alternator bracket:

- (1) Remove the safety wire/cable from the two bolts that attach the alternator bracket to the crankcase. Discard the safety wire/cable.
- (2) Remove the two bolts and washers (Figure 47).
- (3) Remove the safety wire/cable from the idler pulley shaft nut. Discard the safety wire/cable.
- (4) Remove the lock nut and lock washer from the idler pulley shaft. Discard the lock nut and lock washer.
- (5) Remove the, idler pulley shaft, retaining rings, double-row ball bearing, dual alternator idler pulley, alternator idler bearing shield, lock washer and lock nut from the right alternator bracket as an assembly. Discard the retaining rings, lock washer and lock nut.
- (6) Remove the alternator/idler adjusting link and idler pulley spacer from the right alternator bracket.
- (7) Remove the right alternator bracket from the engine.
- (8) Remove the safety wire/cable from the bolt that attaches the right alternator adjusting link to the engine. Discard the safety wire/cable.
- (9) Remove the bolt, washer, and right alternator adjusting link from the engine.

C. To remove the left alternator bracket:

- (1) Remove the four bolts, lock washers, washers, left alternator bracket, and alternator spacer from the engine. Discard the lock washers.

19. Alternator and Bracket Installation

A. To install the left alternator bracket:

- (1) Install the alternator spacer, left alternator bracket, four washers, four new lock washers, and four nuts (Figure 47) on the engine.
- (2) Torque the nuts in accordance with the Standard Torque Tables in the latest revision of the *Service Table of Limits - SSP-1776*.

B. To install the right alternator bracket:

- (1) Install the right alternator bracket, two bolts, and two washers (Figure 47) on the engine.
- (2) Torque the bolts in accordance with the Standard Torque Tables in the latest revision of the *Service Table of Limits - SSP-1776*.
- (3) Install new safety wire/cable on the two bolts. Refer to the latest revision of Service Instruction No. SI-1566.
- (4) Install the new lock nut, washer, idler pulley spacer, alternator/idler adjusting link and dual alternator idler pulley, two new retaining rings, double-row ball bearings, and alternator bearing shield on the right alternator bracket. Torque the nut in accordance with the Standard Torque Tables in the latest revision of the *Service Table of Limits - SSP-1776*.
- (5) Install new safety wire/cable on the idler pulley shaft lock nut. Refer to the latest revision of Service Instruction No. SI-1566.
- (6) Install the bolt, washer, and right alternator adjusting link on the engine. Torque the bolt in accordance with the Standard Torque Tables in the latest revision of the *Service Table of Limits - SSP-1776*.
- (7) Install new safety wire/cable on the two bolts on the right alternator adjusting link (Figure 46). Refer to the latest revision of Service Instruction No. SI-1566.

C. To install either the left or right alternator:

NOTICE: Refer to the *TEO-540-A1A Illustrated Parts Catalog* to ensure the correct approved alternators for your engine are installed.

- (1) Mount the alternator on the alternator bracket (Figure 47).
- (2) Install the bolt, washers, and new slotted nut on the alternator bracket and alternator as shown in Figure 47.
- (3) Install the alternator belt on the alternator per the “Alternator Belt Installation” procedure in this chapter.
- (4) Shim the alternator(s) as required to align the belt to the starter ring gear drive pulley
- (5) Install the alternator adjusting link on the alternator with the bolt and washer as shown in Figure 47.
- (6) Examine and adjust the alternator belt tension per the “Alternator Belt Inspection” section in this chapter.
- (7) Torque the nuts in accordance with the Standard Torque Tables in the latest revision of the *Service Table of Limits - SSP-1776*.
- (8) Install a new cotter pin in each new nut.

20. Alternator Belt Replacement

A. Alternator Belt Removal

- (1) Remove the safety wire/cable from both bolts on the right alternator adjusting link (Figure 46).
- (2) Loosen the bolt that attaches the alternator adjusting link to the alternator (Figure 47).
- (3) Loosen the bolt that attaches the alternator adjusting link to the crankcase (Figure 47).
- (4) Rotate the alternator on the bracket towards the starter ring gear.
- (5) Remove the alternator belt from the alternator pulley and the starter ring gear.

B. Alternator Belt Installation

- (1) Install the alternator belt in the alternator belt groove on the starter ring gear support.
- (2) Install the alternator belt in the groove on the alternator pulley (Figure 48).
- (3) Adjust the alternator belt tension. Refer to the “Alternator Belt Tension Adjustment” procedure for the respective alternator in this chapter.
- (4) Shim the alternator(s) as required to align the belt to the starter ring gear drive pulley.
- (5) Torque the bolts that attach the right alternator adjusting link to the right alternator and to the crankcase to 17 ft.-lb. (23 Nm).
- (6) Install new safety wire/cable on the two bolts on the right alternator adjusting link as shown in Figure 46.

21. Starter Ring Gear Support Replacement

A. Starter Ring Gear Support Removal

- (1) If not already done, release the tension on the alternator belts.

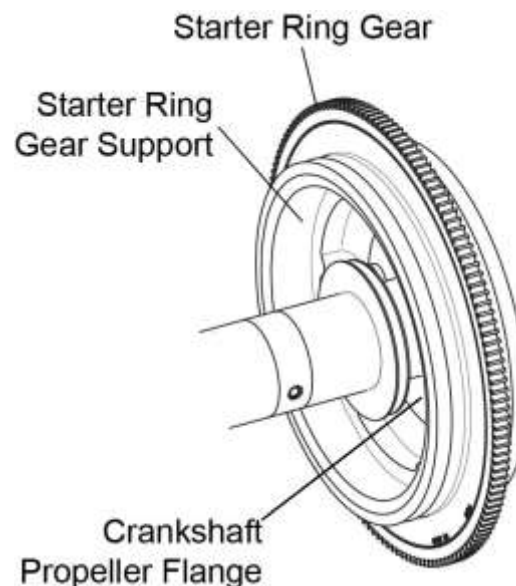


Figure 49
Starter Ring Gear Support

- (2) Remove the alternator belts from the starter ring gear support (Figure 49).
- (3) Remove the starter ring gear support from the crankshaft propeller flange.

B. Starter Ring Gear Support Installation

- (1) Install the alternator belts in the pulley of the starter ring gear support.
- (2) Assemble the ring gear support over the propeller flange bushings.
- (3) Locate the starter ring gear so that the "0" on the ring gear support aligns with the "0" on the crankshaft flange.
- (4) Align the mark on the crankshaft flange (Figure 50) with the mark on the starter ring gear assembly (Figure 51). Install the starter ring gear on the crankshaft flange.
- (5) Adjust the alternator belt tension. Refer to the "Alternator Belt Tension Adjustment" procedure for the respective alternator in this chapter.

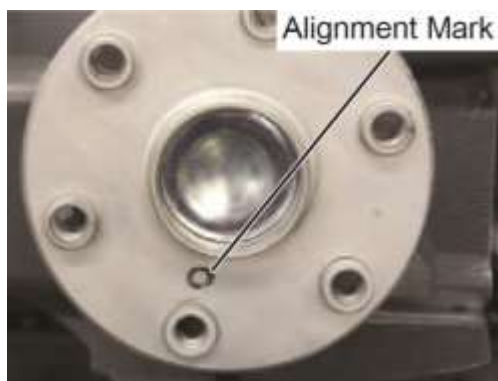


Figure 50
Alignment Mark
on the Crankshaft Flange



Figure 51
Alignment Mark on the Starter Ring Gear

22. Starter Ring Gear Replacement

NOTICE: The following procedure is for replacing a worn or damaged starter ring gear without replacing the starter ring gear support.

A. Starter Ring Gear Removal

- (1) Make sure that none of the propeller bolt holes in the starter ring gear support are worn or out-of-round.
- (2) If you find defective holes, replace the entire starter ring gear assembly.

⚠ CAUTION DO NOT GRIND INTO THE STARTER RING GEAR SUPPORT. IF YOU GRIND INTO THE STARTER RING GEAR SUPPORT, IT MUST BE REPLACED.

- (3) If the propeller bolt holes are satisfactory, grind through the starter ring gear until there is only a thin ring of gear metal. Do not grind into the starter ring gear support.
- (4) Put the starter ring gear on a flat metal surface and break the thin metal ring from the grinding operation. The starter ring gear will spring open for easy removal from the starter ring gear support.

B. Starter Ring Gear Inspection

Examine the starter ring gear face for defects. If the ring gear is damaged, replace it as per instructions in this chapter. Do not use it again.

C. Starter Ring Gear Installation

- (1) Put the starter ring gear support on a flat surface (Figure 52) with the alternator/generator belt groove upward.

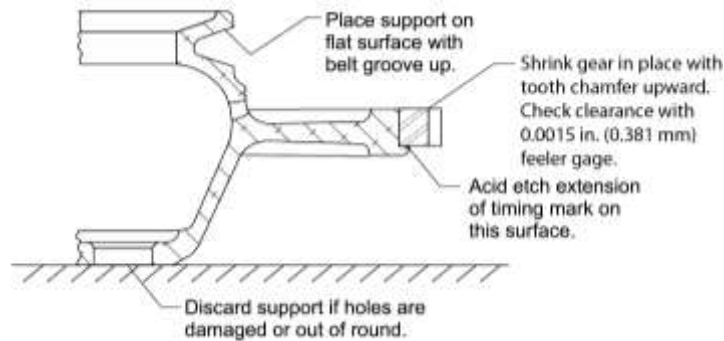


Figure 52
Starter Ring Gear Support

- (2) Heat the new starter ring gear to approx. 450°F (232°C) in an oven or with a torch.
- (3) Assemble the heated gear on the ring gear support (with the tooth chamfer up).

NOTICE: As the starter ring gear cools, it will shrink to the support.

- (4) Use a 0.0015 in. (0.0381 mm) feeler gage to measure the clearance between the ring gear and support at both locations where the ring gear and support surfaces make contact. Measure around the entire circumference. The clearance measurements must be same to ensure correct seating of the ring gear against the support face. Different clearance measurements are an indication of incomplete assembly or warpage and must be corrected.
- (5) Install the starter ring gear support with the new starter ring gear on the crankshaft flange per the “Starter Ring Gear Support Installation” section in this chapter.

This page intentionally left blank.

72-80 - INDUCTION SYSTEM MAINTENANCE

1. Induction System Inspection

- A. Look for leaks at intake pipe connections (Figure 1).
- B. Examine for cracked intake pipes. Replace cracked intake pipes.
- C. Examine intake pipe seal ring for displacement, broken or missing, replace seal ring as required.
- D. Examine for loose flange bolts. Replace the flange gasket and lock washers. Torque the bolt in accordance with the Standard Torque Tables in the latest revision of the *Service Table of Limits - SSP-1776*.

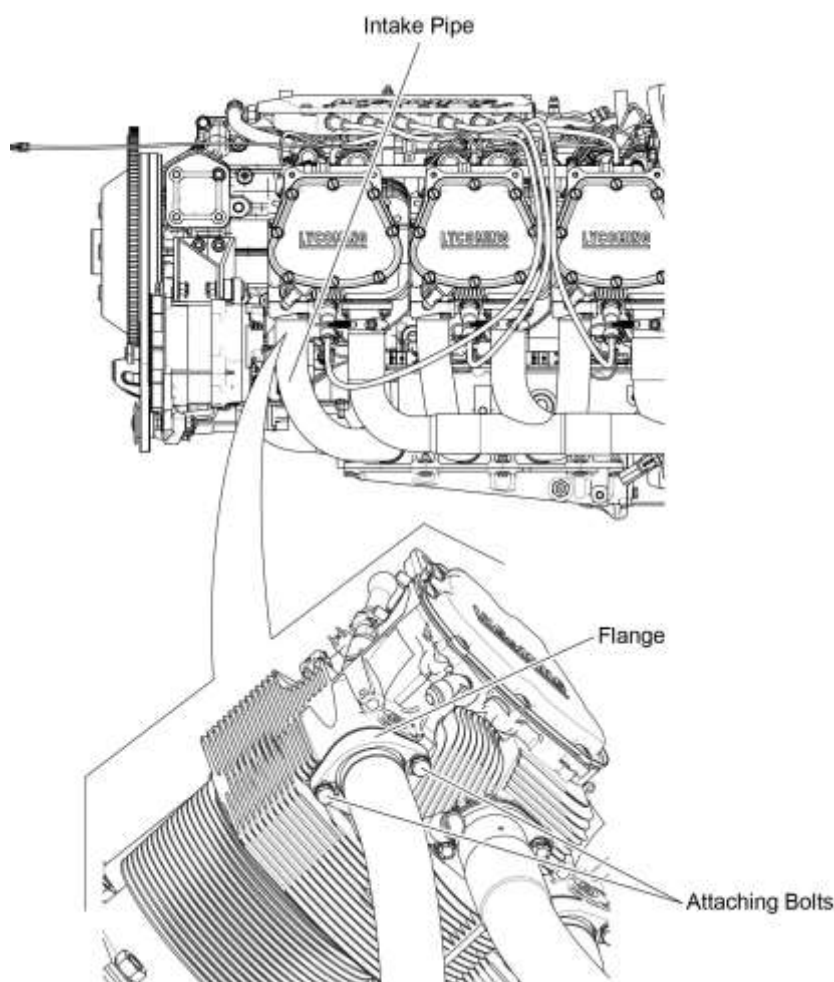


Figure 1
Intake Pipes and Attaching Parts

2. Intake Pipe Replacement

NOTICE: Each engine cylinder has a corresponding intake pipe of a different part number. Be sure to replace the intake pipe with the correct replacement intake pipe that corresponds to the engine cylinder number (Figure 2). Refer to the *TEO-540-A1A Illustrated Parts Catalog* for the part numbers of the correct replacement intake pipes.

A. Intake Pipe Removal

- (1) If removing intake pipe (Figure 2) for either Cylinder Nos. 5 or 6, loosen the hose clamps and remove the heat shield and two hose clamps.
- (2) Remove the two bolts, lock washers, and washers from the intake pipe flange at the engine cylinder (Figure 2). Discard the lock washers.
- (3) Remove the gasket from the intake pipe, discard the gasket.
- (4) If the intake pipe is not to be replaced, attach a label to the intake pipe that identifies the corresponding engine cylinder number for reference on assembly.
- (5) Remove the intake pipe and seal ring at the oil sump connection. Discard the seal ring.

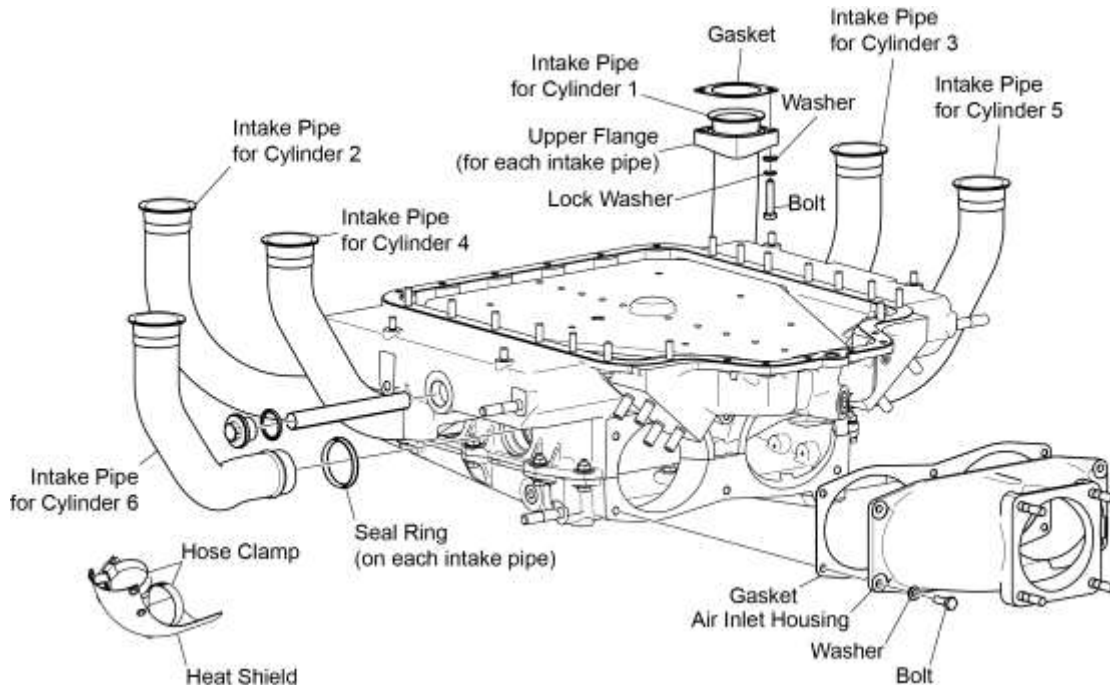


Figure 2
Intake Pipes and Attaching Parts

B. Intake Pipe Installation

NOTICE: Since there is a corresponding intake pipe for each engine cylinder, make sure the correct intake pipe is installed for the respective engine cylinder. Refer to the *TEO-540-A1A Illustrated Parts Catalog* for the part number and installation location of each intake pipe.

- (1) Install the intake pipe with a new seal ring at the oil sump (Figure 2) in the oil sump opening for the corresponding cylinder.
- (2) Attach the corresponding intake pipe to the correct engine cylinder flange with a new gasket, two bolts, two new lock washers, and two washers. Torque the two bolts to 96 to 108 in.-lb. (11 to 12 Nm).
- (3) Install a heat shield with two hose clamps. Tighten the hose clamps to hold the heat shield securely in place.

3. Fuel Drain Valve Adapter Assembly Inspection

The fuel drain valve adapter (Figure 3) is a valve in the induction system that closes during engine operation and opens when the engine is shut down to allow excess fuel to drain from the induction system. If the valve is not operating correctly it can either allow outside air into the induction system during engine operation or fail to drain excess fuel from the induction system when the engine is shut down.

If your engine has a fuel drain valve adapter, examine the assembly as follows:

A. Remove the fuel drain valve adapter assembly from the induction housing (Figure 3).

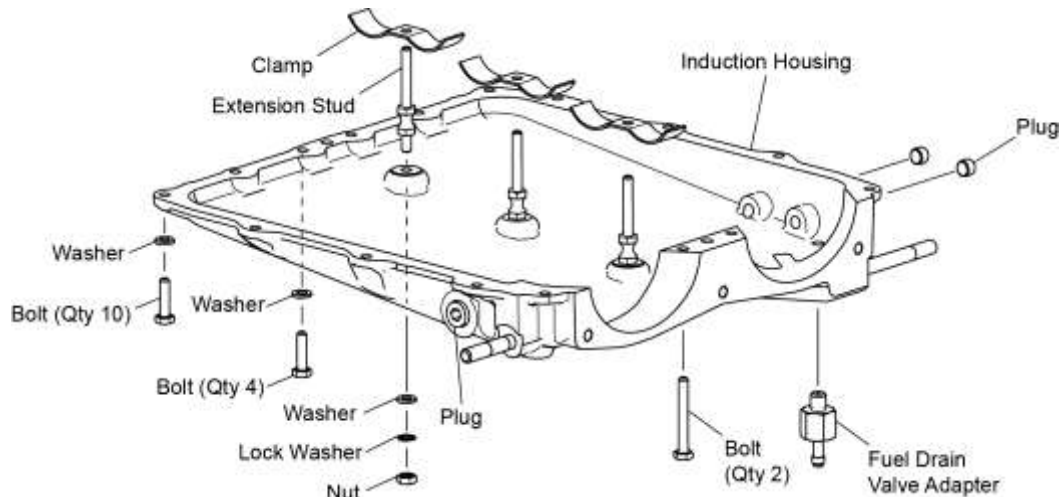


Figure 3
Induction Housing

B. Examine the fuel drain valve adapter for damage.

C. Make sure the fuel drain valve adapter is operating correctly:

- (1) The valve is operating correctly if it is open with no air pressure applied.
- (2) The valve is operating correctly if it closes when 0.75 to 1.0 psi (5.2 to 6.9 kPa) of air pressure is applied to the inboard side of the fuel drain valve adapter assembly, then repeated with the outboard side.

D. If the valve is not operating correctly or if it is damaged, replace the fuel drain valve adapter assembly.

E. Install a serviceable fuel drain valve adapter in the induction housing. Torque the fuel drain valve adapter to 40 in.-lb. (4.5 Nm).

4. Induction Housing Replacement

A. Induction Housing Removal

- (1) Remove the 10 bolts, 20 washers, 10 lock washers, and nuts from the induction housing and oil sump (Figure 3). Discard the lock washers.
- (2) Remove the four bolts and washers from the induction housing.
- (3) Remove the induction housing.

B. Induction Housing Installation

- (1) Install the induction housing on the oil sump.
- (2) Install and torque the four bolts and 10 bolts with new lock washers in the induction housing per the Standard Torque Tables in the latest revision of the *Service Table of Limits - SSP-1776*.

5. Air Inlet Housing Replacement**A. Air Inlet Housing Removal**


- (1) Remove the six bolts and washers from the air inlet housing (Figure 2).
- (2) Remove the air inlet housing and gasket from the induction housing. Discard the gasket.


B. Air Inlet Housing Installation

- (1) Install the air inlet housing (Figure 2) with a new gasket on the induction housing with the six bolts and washers.
- (2) Torque the bolts to 96 to 106 in.-lb. (11 to 12 Nm).

73-10 - ENGINE FUEL AND CONTROL – DISTRIBUTION MAINTENANCE

1. Fuel System Inspection

 WARNING DO NOT SMOKE OR HAVE AN OPEN FIRE/FLAME OR USE ANY DEVICE THAT CAN MAKE SPARKS DURING THIS INSPECTION. FLAMES OR SPARKS CAN CAUSE FUEL IGNITION WHICH CAN CAUSE SERIOUS BURNS, INJURY, OR DEATH.

 CAUTION TO ENSURE CORRECT ENGINE OPERATION AND FLIGHT SAFETY, THERE MUST NOT BE ANY FUEL LEAK AND ALL FUEL HOSES MUST BE SECURED WITH CLAMPS (PER THE “FUEL HOSE INSPECTION” PROCEDURE IN THIS CHAPTER). IDENTIFY AND CORRECT THE CAUSE OF ANY FUEL LEAK.

NOTICE: This inspection is to be done every 100 hours.

- A. Make a copy of the Fuel System Inspection Checklist in this chapter and complete this checklist for this inspection.
- B. Examine the fuel pump for secure attachment and damage. Replace a damaged or malfunctioning fuel pump. Tighten any loose fasteners in accordance with the Standard Torque Tables in the latest revision of the *Service Table of Limits - SSP-1776*.
- C. Examine the two fuel injector rail assemblies (Figure 1) for damage, leaks, and loose fittings or connections. Tighten any loose fittings or connection in accordance with the Standard Torque Tables in the latest revision of the *Service Table of Limits - SSP-1776*. Replace a damaged fuel injector rail assembly per the “Fuel Injector Rail Assembly Replacement” section in this chapter.
- D. Examine the weld joints at the end of both fuel injector rail assemblies for cracks. Replace the fuel injector rail assembly if the weld joint is cracked.
- E. Examine the fuel injector and fire sleeves (Figures 1 and 9) for damage, leaks, and loose fittings or connections. If the fuel injector fire sleeves are damaged, replace them. Tighten any loose fittings or connection in accordance with the Standard Torque Tables in the latest revision of the *Service Table of Limits - SSP-1776*. Replace a damaged fuel injector per the “Fuel Injector Replacement” section in this chapter.
- F. Examine fuel hose fittings for damage or leaks. Make sure all fuel hose fittings and connections are secure and correctly torqued per the Standard Torque Tables in the latest revision of the *Service Table of Limits - SSP-1776*. If tightening does not correct a fuel leak, replace the fitting.
- G. Remove the fuel inlet strainers from the inlet side and clean the inlet strainer.
- H. Complete the “Fuel Hose Inspection” procedure in this chapter.
- I. Make sure the power control and linkage have full travel, freedom of movement.
- J. Lubricate the linkage per the aircraft manufacturer's instruction.
- K. Operate the engine and look for leaks. Identify and correct the cause of any leak or malfunction. If leaks or malfunctions were found and corrected, operate the engine again to make sure it is operating correctly and there is no leak anywhere.
- L. Do not return the engine to service unless the engine is operating correctly and does not have any leaks.

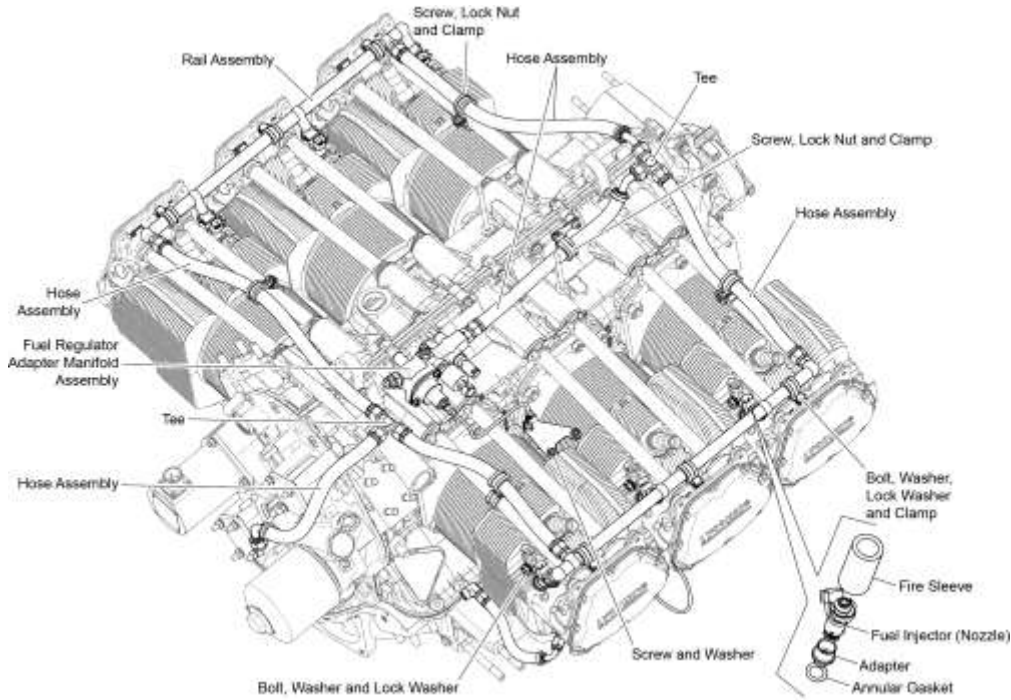


Figure 1
Fuel System Components

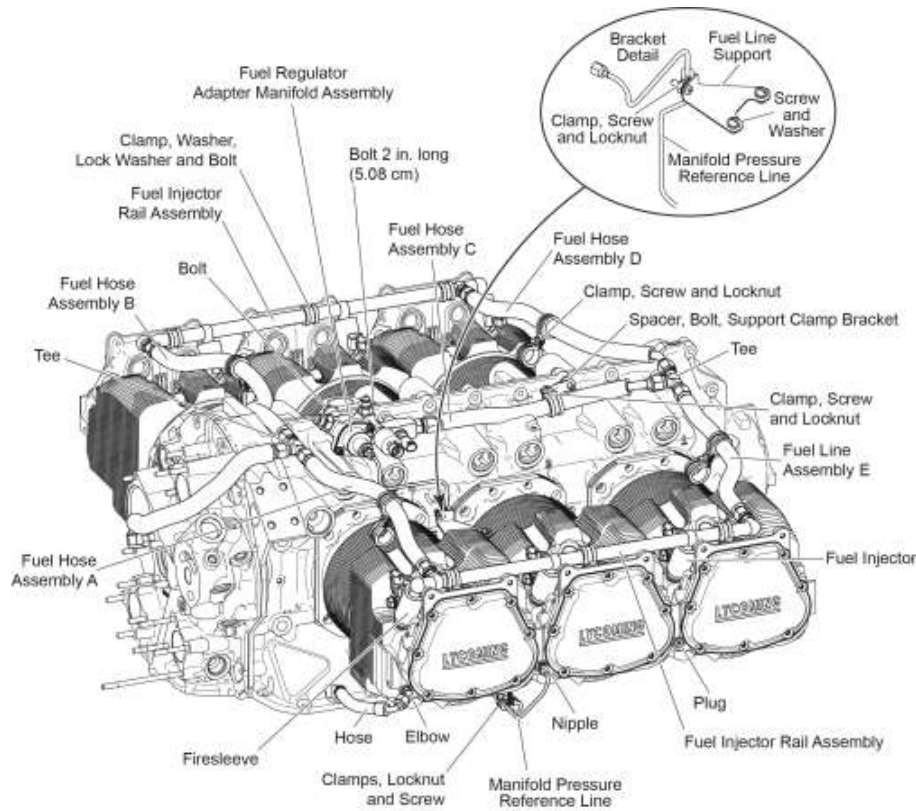




Figure 2
Fuel Distribution System


2. Fuel Hose Inspection

 **WARNING** DO NOT SMOKE OR HAVE AN OPEN FIRE/FLAME OR USE ANY DEVICE THAT CAN MAKE SPARKS DURING THIS INSPECTION. FLAMES OR SPARKS CAN CAUSE FUEL IGNITION WHICH CAN CAUSE SERIOUS BURNS, INJURY, OR DEATH.

 **CAUTION** TO ENSURE CORRECT ENGINE OPERATION AND FLIGHT SAFETY, THERE MUST NOT BE ANY FUEL LEAK AND ALL FUEL HOSES MUST BE SECURED WITH SERVICEABLE CUSHIONED CLAMPS. IDENTIFY AND CORRECT THE CAUSE OF ANY FUEL LEAK.

NOTICE: This fuel hose inspection is to be done during every visual inspection, after every 100 hours of engine operation, and any time fuel hoses or clamps are serviced, removed, or replaced. Copy and record findings in the Fuel System Inspection Checklist in this chapter.

- A. There are six fuel hoses (or lines) on this engine (Figure 3). For reference, identify each fuel hose by number.
- B. Examine each fuel hose for damage, leaks, dents, pits, nicks, kinks, stains (from fuel leaks), cracks, brittleness, nearby heat sources, chafing, looseness, and sharp bends. Refer to Figure 4 which shows the minimum acceptable bend radius for a bend in the fuel hose. Replace (**do not try to repair**) a worn, damaged, chafed, brittle, kinked, or loose fuel hose. (A loose fuel hose could have been subjected to vibrational forces and be weakened. Cracks can develop at kinks in fuel hoses.)

 **CAUTION** TO SUPPORT FUEL SYSTEM PERFORMANCE, ALL WORN, DAMAGED, CHAFED, BRITTLE, KINKED, OR LOOSE FUEL HOSES MUST BE REPLACED - NOT REPAIRED. MAKE SURE EACH FUEL HOSE IS INSTALLED WITH SERVICEABLE CUSHIONED CLAMPS TO KEEP THE FUEL HOSES SECURELY IN PLACE TO PREVENT FUEL HOSE DAMAGE DUE TO VIBRATION AND FRICTION AGAINST OTHER PARTS OF THE ENGINE. VIBRATION, RUBBING, AND/OR KINKS IN THE FUEL HOSES CAN CAUSE CRACKS IN THE FUEL HOSES. AS A RESULT, THE FUEL HOSES CAN EVENTUALLY BREAK, LEAK FUEL ON THE ENGINE, AND CAUSE A FIRE OR ENGINE STOPPAGE.

- C. Make sure all fuel hoses are held in place securely using serviceable cushioned clamps to prevent fuel hose movement due to vibration.
 - (1) Make sure each clamp securely supports the fuel hose to prevent fuel hose movement due to vibration, friction, or motion frequencies. **Do NOT use plastic tie straps as clamps.**
 - (2) Examine the cushion on clamps for deterioration. If cushions are deteriorated or missing, replace the clamp with a new clamp with the cushion intact. The fuel hose could need to be replaced per guidelines in Table 1.
 - (3) **If a fuel hose had been in service and clamps were not installed, replace the fuel hose with a new fuel hose (as a precaution since vibration can cause cracks in the fuel hoses.)**
 - (4) Make sure the clamps are securely attached. If the clamps are loose, replace the fuel hose.

⚠ CAUTION REPLACE ANY FUEL HOSE THAT IS BRITTLE, CRACKED, DENTED, OR KINKED; CRACKS CAN DEVELOP AT THE SITE OF SHARP BENDS OR KINKS.

D. Examine solder joints at the end of fuel hoses for cracks. Replace the fuel hose if a crack is found at a solder joint.

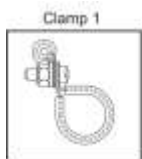
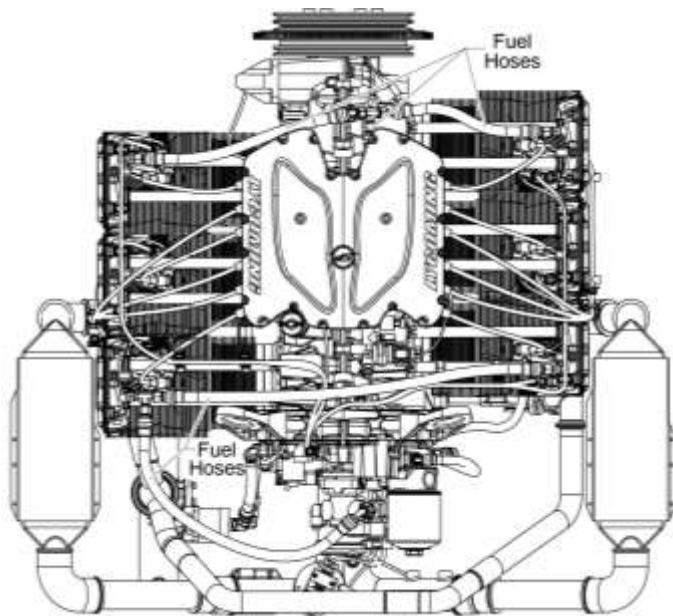
NOTICE: Figure 3 is an example of a fuel hose routing configuration for this engine. This figure is conceptual and for reference only. Fuel hose routing on your engine could have a different configuration.

⚠ WARNING DO NOT ROUTE FUEL HOSES CLOSE TO HEAT SOURCES. HEAT CAN CAUSE FUEL VAPORIZATION IN THE FUEL HOSES OR CAN DAMAGE THE FUEL HOSE AND CAUSE A FUEL LEAK WHICH COULD LEAD TO ENGINE STOPPAGE OR A FIRE.

⚠ CAUTION DO NOT RETURN THE ENGINE TO SERVICE UNLESS THE ENGINE IS OPERATING CORRECTLY AND DOES NOT HAVE ANY LEAKS.

E. Make sure no fuel hoses touch the engine or aircraft baffle hardware. There must be a minimum clearance of 3/16 in. (4.76 mm) between a fuel hose and any engine or aircraft surface.

F. After the inspection, refer to Table 1 for any corrective action if necessary.



LW-16286-10-75 Clamp
LW-16286-10-13 Clamp
STD-860 Screw
STD-670 Nut



LW-16286-25-63 Clamp
STD-860 Screw
STD-425 Washer
STD-670 Nut

Figure 3

TEO-540-A1A Fuel Hose Routing and Clamps

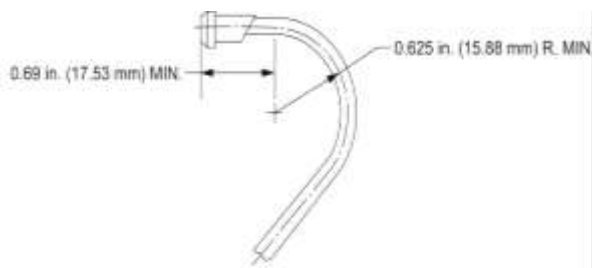



Figure 4
Minimum Acceptable Bend Radius
for a Bend in the Manifold Pressure
Reference Line

Table 1
Corrective Action for Fuel Hoses

Condition	Corrective Action
Leaky, cracked, brittle, worn, chafed, fuel hose	Do NOT repair any fuel hose that leaks or is cracked, brittle worn, or chafed. Replace the fuel hose with a new fuel hose.
Damaged, brittle, cracked, kinked, loose, crimped fuel hose	Do NOT re-use any fuel hose that is damaged, brittle, cracked, or kinked. Replace the fuel hose with a new fuel hose.
No clamps installed on fuel hose that had been in service	Replace the fuel hose with a new fuel hose (as a precaution) and install serviceable cushioned clamps on the fuel hose to securely hold the fuel hose in place and prevent fuel hose movement from vibration.
Loose clamps	Replace the fuel hose with a new fuel hose and install serviceable cushioned clamps on the fuel hose to securely hold the fuel hose in place to prevent fuel hose movement from vibration.
Deteriorated cushion on clamp, missing cushion, or cushion does not completely cover the fuel hose diameter.	Examine fuel hoses in areas adjacent to the clamp. Replace any fuel hose that has missing or deteriorated cushions on clamps.
Problem with fuel injector clamp installation caused by obstructive baffling	Install the fuel injector clamps to enable clearance.

3. Fuel Injector Leak Check

 WARNING DO NOT SMOKE OR HAVE AN OPEN FIRE FLAME OR USE ANY DEVICE THAT CAN MAKE SPARKS. FLAMES OR SPARKS CAN CAUSE FUEL IGNITION WHICH CAN CAUSE SERIOUS BURNS, INJURY OR DEATH. MAKE SURE THERE IS ADEQUATE VENTILATION ANY TIME THE ENGINE FUEL SYSTEM IS OPENED. FAILURE TO PROVIDE ADEQUATE VENTILATION COULD RESULT IN INJURY OR DEATH OF PERSONNEL.

A. Equipped with Airframe Boost Pump

NOTICE: Complete this procedure on each suspect leaky fuel injector.

- (1) Apply power to the aircraft.
- (2) Turn on the airframe boost pump.
- (3) Examine the inlet of each fuel injector (Figure 1) and fuel injector rail assembly for leaks. Replace any fuel injectors that are leaking. Refer to the section "Fuel Injector Replacement" in this chapter.
- (4) Turn off the airframe boost pump.
- (5) Start the engine and operate it for 3 minutes.

- (6) Shut down engine and look for fuel leaks (wet spots or pooled fuel) behind the fuel injector adapter in the cylinders. Replace any adapter that is leaking. Refer to the sections "Removal of Adapter from Fuel Injector" and "Installation of Adapter on Fuel Injector" in this chapter.

⚠ CAUTION DO NOT RETURN THE ENGINE TO SERVICE UNLESS THE ENGINE IS OPERATING CORRECTLY AND DOES NOT HAVE ANY LEAKS.

- (7) Look for any fuel leaks. Identify and correct the cause of any fuel leaks. There must not be any fuel leaks. All fuel connections must be secure and torqued in accordance with the Standard Torque Tables in the latest revision of the *Service Table of Limits - SSP-1776*.
- (8) If leaks or malfunctions were found and corrected, operate the engine again to make sure it is operating correctly and there is no leak anywhere.

B. Without Airframe Boost Pump

NOTICE: Complete this procedure on each suspect leaky fuel injector.

- (1) Apply power to the aircraft.
- (2) Start the engine and operate it for 3 minutes.
- (3) Shut down engine and look for fuel leaks (wet spots or pooled fuel) around the fuel injector inlet, fuel injector rail assembly (Figure 1), and injector adapter in the cylinder. Replace any fuel injector, rail, or adapter that leaks per procedures in this chapter.

⚠ CAUTION DO NOT RETURN THE ENGINE TO SERVICE UNLESS THE ENGINE IS OPERATING CORRECTLY AND DOES NOT HAVE ANY LEAKS.

- (4) Look for any fuel leaks. Identify and correct the cause of any fuel leaks. There must not be any leaks. All fuel connections must be secure and torqued in accordance with the Standard Torque Tables in the latest revision of the *Service Table of Limits - SSP-1776*.
- (5) If leaks or malfunctions were found and corrected, operate the engine again to make sure it is operating correctly and there is no leak anywhere.

4. Fuel System Inspection

Copy and complete the Fuel System Inspection Checklist.

Fuel System Inspection Checklist

Engine Model: TEO-540-A1A	Date of Inspection:		Inspector:
Inspection Item	Fuel Hose	Findings	Corrective Action Taken
Examine the fuel pump for secure attachment and damage. Replace a damaged or malfunctioning fuel pump per the "Fuel Pump Replacement" procedure in this chapter	N/A		

Fuel System Inspection Checklist (Cont.)


Inspection Item	Fuel Hose	Findings	Corrective Action Taken
Examine the fuel injector rail assembly for damage, leaks, and loose fittings or connections. Tighten any loose fitting or connection.* Replace a damaged fuel injector rail assembly per the “Fuel Injector Rail Assembly Replacement” procedure in this chapter.	N/A		
Examine the fuel injectors for damage, leaks, and loose fittings or connections. Tighten any loose fitting or connection.* Replace a damaged fuel injector per the “Fuel Injector Replacement” procedure in this chapter.	Cyl. 1		
	Cyl. 2		
	Cyl. 3		
	Cyl. 4		
	Cyl. 5		
	Cyl. 6		
NOTICE: Fuel hoses are identified as A, B, C, D, and E in Figure 7			
Examine fuel hose fittings for damage or leaks. Unless otherwise stated, make sure all fuel hose fittings and connections are secure and correctly torqued.* If tightening does not correct a fuel leak, replace the fitting.	A		
	B		
	C		
	D		
	E		
Examine each fuel hose for damage, leaks, nicks, dents, pits, nicks, kinks, stains (from fuel leaks), cracks, brittleness, nearby heat sources, chafing, and looseness. Replace (do not try to repair) a worn, damaged, kinked, chafed, cracked, brittle, or loose fuel hose per the “Fuel Hose Replacement” procedure in this chapter. Make sure no fuel hoses touch the engine or aircraft baffle hardware. There must be a minimum clearance of 3/16 in. (4.76 mm) between a fuel hose and any engine or aircraft surface. In general, make sure fuel hoses do not touch heat sources.	A		
	B		
	C		
	D		
	E		
* Per the Standard Torque Tables in the latest revision of the <i>Service Table of Limits - SSP-1776</i> .			

Fuel System Inspection Checklist (Cont.)

Inspection Item	Fuel Hose	Findings	Corrective Action Taken
Make sure each fuel hose is held in place securely using serviceable cushioned clamps to prevent fuel hose movement due to vibration. <u>If a fuel hose had been in service and clamps were not installed, replace the fuel hose with a new fuel hose.</u> Make sure clamps are securely attached. If the clamps are loose, replace the fuel hose. Install new clamps that attach the hose securely.	A		
	B		
	C		
	D		
	E		
Examine the cushion on clamps for deterioration. If cushions are deteriorated or missing, replace the fuel hose and the clamp with a new clamp with the cushion intact.	A		
	B		
	C		
	D		
	E		
Examine solder joints, as necessary, at the end of each fuel hose for cracks. Replace the fuel hose if a crack is found at a solder joint.			
Operate the engine and look for fuel leaks. Identify and correct the cause of any fuel leak or malfunction. Operate the engine again to make sure it is operating correctly and there is no leak anywhere.	N/A		
Tighten any loose fasteners, fittings, or connections.*	N/A		

* Per the Standard Torque Tables in the latest revision of the *Service Table of Limits - SSP-1776*.

5. Fuel Hose Replacement

 WARNING DO NOT SMOKE OR HAVE AN OPEN FIRE FLAME OR USE ANY DEVICE THAT CAN MAKE SPARKS. FLAMES OR SPARKS CAN CAUSE FUEL IGNITION WHICH CAN CAUSE SERIOUS BURNS, INJURY OR DEATH.

 CAUTION DO NOT ATTEMPT TO REPAIR A DAMAGED FUEL HOSE. REPLACE ANY FUEL HOSE THAT IS BRITTLE, CRACKED, OR KINKED; CRACKS CAN DEVELOP AT THE SIDE OF SHARP BENDS OR KINKS.

NOTICE: If this fuel hose replacement procedure is completed with the engine installed in the airframe, refer to the airframe manufacturer's instructions for shutting off the fuel and grounding the aircraft.

A. Fuel Hose Removal

- (1) Put a fuel collection container under the fuel hose (Figure 3) at each fitting connection.
- (2) Make a sketch to identify clamps that attach to brackets for reference on assembly.
- (3) Remove and discard the P and L clamps (Figures 5 and 6) from the fuel hose.
- (4) Disconnect the fuel hose from the fitting on each end.
- (5) Remove the fuel hose. (Keep the fuel fittings if they are not part of the fuel hose.)

NOTICE: If no clamps were attached to the fuel hose, replace the fuel hose and install serviceable cushioned clamps to dampen vibration.

B. Fuel Hose Installation

 WARNING DO NOT ROUTE FUEL HOSES CLOSE TO HEAT SOURCES. HEAT CAN DAMAGE THE FUEL HOSE AND CAUSE A FUEL LEAK WHICH COULD LEAD TO CATASTROPHIC ENGINE FAILURE.

NOTICE: Refer to the *TEO-540-A1A Illustrated Parts Catalog* fuel hose part numbers. Figure 3 shows a conceptual example of a fuel hose routing configuration. Some fuel hose configurations can either use short or long fuel injector lines. Your fuel hose routing configuration could be different.

- (1) Do not let the fuel hose touch the engine or aircraft baffle hardware.
- (2) Make sure there is a minimum clearance of 3/16 in. (4.76 mm) between a fuel hose and any engine or aircraft surface.
- (3) Make sure the fuel hose is not crimped or kinked, there are no cracks at solder joints, and the fuel hose is in compliance with Figure 4 for the minimum acceptable bend in the fuel hose.

NOTICE: If installing a new fuel hose where fittings were not attached as part of the fuel hose assembly, the fitting can be installed if the threads are not damaged.

- (4) Connect the fuel hose to the fuel fitting on each end.

- (5) Torque each fuel hose fitting in accordance with the Standard Torque Tables in the latest revision of the *Service Table of Limits - SSP-1776*.
- (6) Make sure that the fuel hoses are securely held in place, attached to the engine (to dampen vibration during flight) with the necessary serviceable cushioned clamps and hardware. Install clamps on the fuel hose as per the following guidelines:
 - (a) Make sure each serviceable clamp securely supports the fuel hose to prevent fuel hose movement due to vibration, friction, or motion frequencies during flight. **Do NOT use plastic tie straps as clamps.**
 - (b) Install serviceable cushioned clamps on the fuel hose. Make sure the cushion is not missing and is intact, and completely covers the fuel hose diameter. If cushions are deteriorated or missing, replace the clamp with a new clamp with the cushion intact.
 - (c) Refer to Figures 5 and 6 which show how the fasteners are to be installed on P-clamps and L-shaped clamps.



Figure 5
P-Clamp

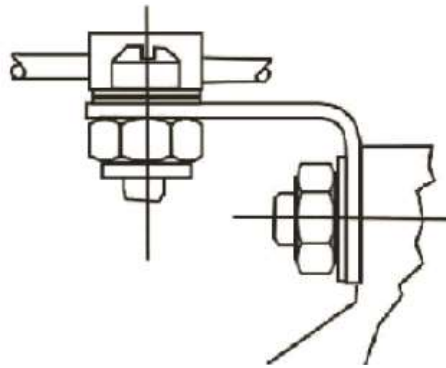


Figure 6
L-Shape Clamp

- (d) Make sure the clamps are securely attached to support the fuel hose and to prevent movement from vibration or motion frequencies.
- (e) Torque the fuel hose connections in accordance with the Standard Torque Tables in the latest revision of the *Service Table of Limits - SSP-1776*.

⚠ CAUTION TO ENSURE CORRECT ENGINE OPERATION AND FLIGHT SAFETY, THERE MUST NOT BE ANY FUEL LEAK AND ALL FUEL HOSES MUST BE SECURED WITH CLAMPS. IDENTIFY AND CORRECT THE CAUSE OF ANY FUEL LEAK.

- (7) Complete the operational ground check in Chapter 72-00 after all maintenance is complete. Look for fuel leaks at the fuel hoses and connections during engine operation. Identify and correct the cause of any fuel leak. There must not be any fuel leak when the engine is returned to service.
- (8) Remove the fuel collection container and dispose of the fuel in accordance with environmental regulations.

6. Fuel Injector Rail Assembly Replacement

⚠ WARNING DO NOT SMOKE OR HAVE AN OPEN FIRE FLAME OR USE ANY DEVICE THAT CAN MAKE SPARKS. FLAMES OR SPARKS CAN CAUSE FUEL IGNITION WHICH CAN CAUSE SERIOUS BURNS, INJURY, OR DEATH.

NOTICE: As shown in Figure 7, there are two fuel injector rail assemblies, one on each side of the engine. Each fuel injector rail assembly is attached to fuel hoses and the fuel injectors on the three engine cylinders on each side of the engine.

If this fuel injector rail assembly replacement procedure is completed with the engine installed in the airframe, refer to the airframe manufacturer's instructions for shutting off the fuel and grounding the aircraft.

A. Fuel Injector Rail Assembly Removal

- (1) Remove the harness connector from all three fuel injectors on the affected fuel injector rail assembly.
- (2) Remove the screw and lock nut from each of the two clamps that attach the wiring harness to the fuel injector rail assembly. Discard the lock nuts.
- (3) Move the wiring harness so it does not interfere with fuel injector rail assembly removal.
- (4) Put a fuel collection container under the side of the engine where the fuel injector rail assembly (Figure 7) is to be removed.

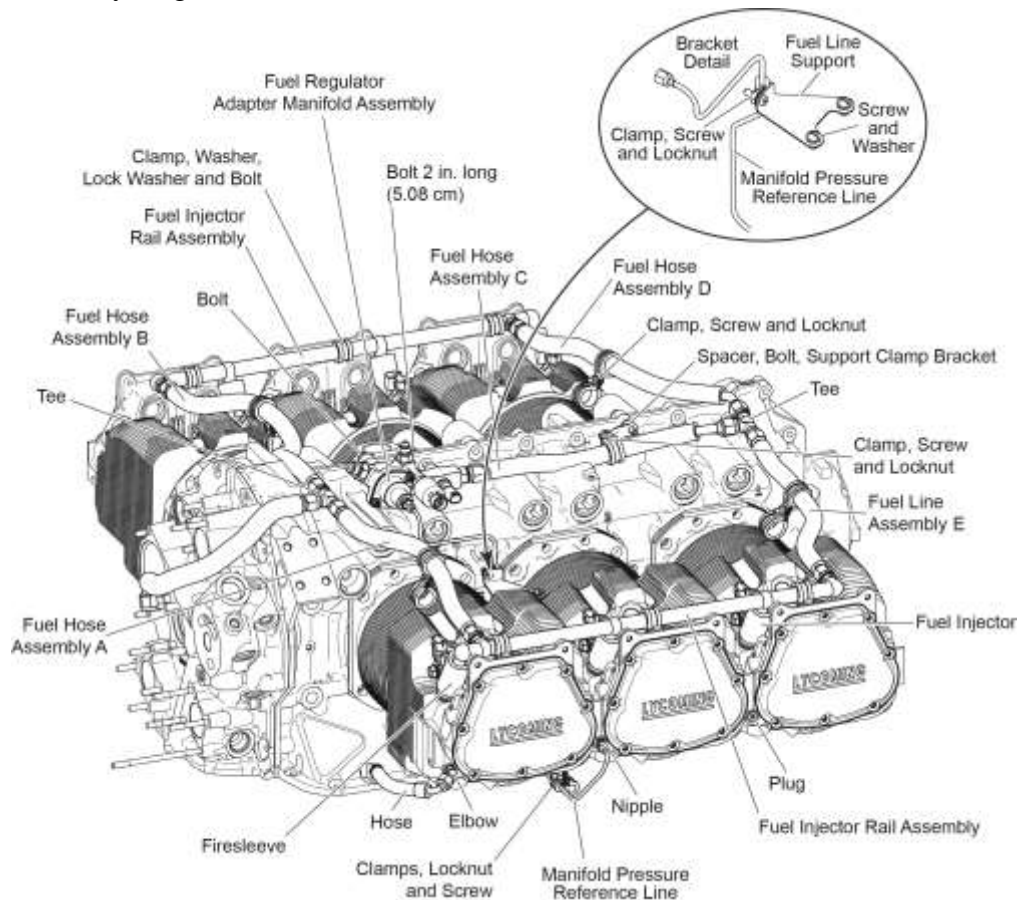


Figure 7
Fuel Distribution System

- (5) Loosen the cap on the fuel pressure regulator bleed port to release pressure from the fuel hoses.
- (6) Disconnect the two fuel hoses (identified as A and E or B and D in Figure 7) from the fuel injector rail assembly coupling at each end of the fuel injector rail assembly to be removed.
- (7) Remove the bolt, washer, and lock washer from each clamp on the fuel injector rail assembly (Figure 8). Discard the lock washers. Keep the hardware fasteners and clamps.

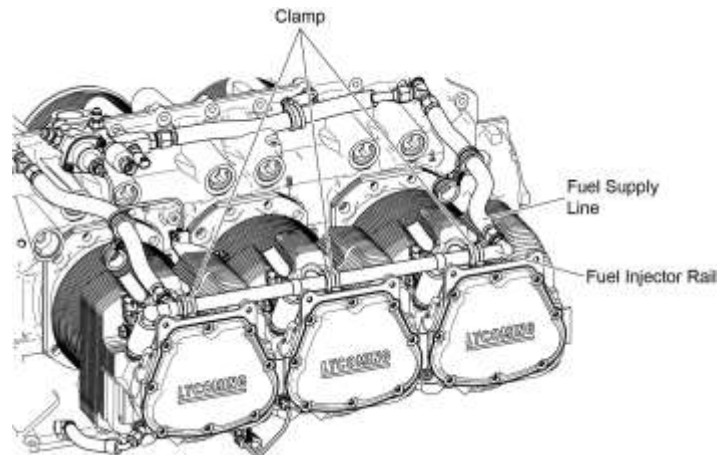


Figure 8
Fuel Injector Rail Assembly

- (8) Cut and remove the safety wire from the fire sleeve on the fuel injector (Figure 9)
- (9) Move the locking clip to unlock each fuel injector from the fuel injector rail.
- (10) Remove the fuel injector rail from the fuel injectors.
- (11) Remove the three fuel injectors from the fuel injector adapters.
- (12) Remove the fuel collection container and dispose of the fuel in accordance with environmental regulations.

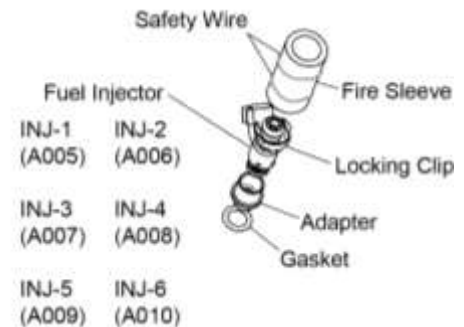


Figure 9
Fuel Injector

B. Fuel Injector Rail Assembly Installation


- (1) Lubricate the fuel injector O-rings with silicone spray.

⚠ CAUTION DO NOT DAMAGE THE FUEL INJECTOR O-RING DURING INSTALLATION. LOSS OF FUEL SYSTEM PRESSURE AND FUEL LEAKAGE COULD OCCUR AND CAUSE A POTENTIAL FIRE HAZARD.

NOTICE: Make sure the fuel injector(s) to be installed are acceptable.


- (2) Install the new lubricated O-ring on each fuel injector.
- (3) Install the three fuel injectors (with the fire sleeve installed on the injectors) on the fuel injector rail.

- (4) Make sure the fuel injectors are oriented correctly on the fuel rail. Move the locking clip to lock each fuel injector to the fuel injector rail.
- (5) Safety wire the fire sleeve (Figure 9).
- (6) Install the fuel injector rail with the fuel injectors installed (Figure 7) on the engine with the fuel injectors installed in the fuel injector adapters.
- (7) Torque the coupling on each end of the fuel injector rail in accordance with the Standard Torque Tables in the latest revision of the *Service Table of Limits - SSP-1776*.
- (8) Install the clamps on the fuel injector rail each with a bolt, washer, and new lock washer. Torque the bolts in accordance with the Standard Torque Tables in the latest revision of the *Service Table of Limits - SSP-1776*.
- (9) Connect the fuel hoses (A and E or B and D in Figure 7) to the fuel injector rail coupling at each end of the fuel injector rail. Torque in accordance with the Standard Torque Tables in the latest revision of the *Service Table of Limits - SSP-1776*.
- (10) Attach the each of the three fuel injector harness connectors to applicable fuel injectors.
- (11) Attach the wiring harness to the fuel injector rail with the two clamps, screws, and new lock nuts. Torque the lock nuts in accordance with the Standard Torque Tables in the latest revision of the *Service Table of Limits - SSP-1776*.
- (12) Install and tighten the bleed cap on the fuel pressure regulator bleed port.

 **CAUTION** DO NOT RETURN THE ENGINE TO SERVICE UNLESS THE ENGINE IS OPERATING CORRECTLY AND DOES NOT HAVE ANY LEAKS. THERE MUST NOT BE ANY FUEL LEAKS. A FUEL LEAK CAN CAUSE A FIRE.

- (13) Look for any fuel leaks. Identify and correct the cause of any fuel leaks. There must not be any leaks. All fuel connections must be secure and torqued in accordance with the Standard Torque Tables in the latest revision of the *Service Table of Limits - SSP-1776*.
- (14) If leaks or malfunctions were found and corrected, operate the engine again to make sure it is operating correctly and there is no leak anywhere.

7. Fuel Injector Replacement

 **WARNING** DO NOT SMOKE OR HAVE AN OPEN FIRE FLAME OR USE ANY DEVICE THAT CAN MAKE SPARKS. FLAMES OR SPARKS CAN CAUSE FUEL IGNITION WHICH CAN CAUSE SERIOUS BURNS, INJURY OR DEATH.

NOTICE: If this fuel injector replacement procedure is completed with the engine installed in the airframe, refer to the airframe manufacturer's instructions for shutting off the fuel and grounding the aircraft.


A. Fuel Injector Removal

NOTICE: All three fuel injectors are removed per the "Fuel Injector Rail Assembly Removal" procedure, regardless of how many fuel injectors are replaced.

- (1) Remove the fuel injector rail and the three fuel injectors per instructions in the "Fuel Injector Rail Assembly Removal" section of this chapter.
- (2) Carefully remove the safety wire from the fire sleeve of the fuel injector (Figure 9) to prevent damage to the fire sleeve.

- (3) Remove the fire sleeve from the fuel injector to be replaced.
- (4) Discard the fuel injector to be replaced.
- (5) Remove the fuel collection container and dispose of the fuel in accordance with environmental regulations.


B. Fuel Injector Installation

 **CAUTION** DO NOT DAMAGE THE FUEL INJECTOR O-RING DURING INSTALLATION. LOSS OF FUEL SYSTEM PRESSURE AND FUEL LEAKAGE COULD OCCUR AND CAUSE A POTENTIAL FIRE HAZARD.

NOTICE: Fuel injectors are identical and can be installed in any of the six cylinders in the engine.

- (1) Make sure the fuel injector(s) to be installed are acceptable.
- (2) Install the fuel injector rail and fuel injectors per instructions in the “Fuel Injector Rail Assembly Installation” section of this chapter.

8. Fuel Injector Adapter Replacement

 **WARNING** DO NOT SMOKE OR HAVE AN OPEN FIRE FLAME OR USE ANY DEVICE THAT CAN MAKE SPARKS. FLAMES OR SPARKS CAN CAUSE FUEL IGNITION WHICH CAN CAUSE SERIOUS BURNS, INJURY OR DEATH.

NOTICE: If this fuel injector adapter replacement procedure is completed with the engine installed in the airframe, refer to the airframe manufacturer’s instructions for shutting off the fuel and grounding the aircraft.

A. Removal of Adapter from Fuel Injector

- (1) Remove the fuel injector rail per instructions in the “Fuel Injector Rail Assembly Removal” section of this chapter.
- (2) Remove the fuel injector adapter (Figure 9) to be replaced from the engine cylinder.
- (3) Discard the fuel injector adapter and the annular gasket.

B. Installation of Adapter on Fuel Injector

 **CAUTION** DO NOT DAMAGE THE FUEL INJECTOR O-RING DURING INSTALLATION. LOSS OF FUEL SYSTEM PRESSURE AND FUEL LEAK COULD OCCUR CREATING A POTENTIAL FIRE HAZARD.

- (1) Apply Loctite[®] 569 to the threads of the fuel injector adapter.
- (2) Install a new annular gasket on the fuel injector adapter.
- (3) Install the new fuel injector adapter with the new annular gasket in the engine cylinder. Torque the fuel injector adapter to 12 ft.-lb. (16 Nm).
- (4) Install the fuel injector rail and fuel injectors per instructions in the “Fuel Injector Rail Assembly Installation” section of this chapter.

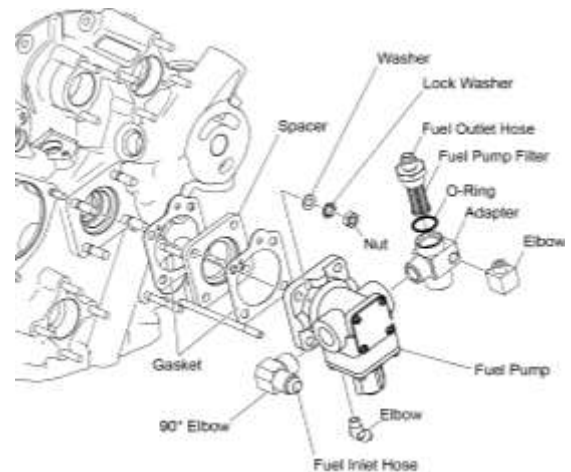
9. Fuel Pump Filter Replacement

⚠ WARNING DO NOT SMOKE OR HAVE AN OPEN FIRE FLAME OR USE ANY DEVICE THAT CAN MAKE SPARKS. FLAMES OR SPARKS CAN CAUSE FUEL IGNITION WHICH CAN CAUSE SERIOUS BURNS, INJURY OR DEATH.

NOTICE: If this fuel pump filter replacement procedure is completed with the engine installed in the airframe, refer to the airframe manufacturer's instructions for shutting off the fuel and grounding the aircraft.

A. Fuel Pump Filter Removal

- (1) Put a fuel collection container under the engine where the fuel hose connects to the fuel pump filter (Figure 10).
- (2) Loosen the cap on the fuel pressure regulator bleed port to release pressure from the fuel hoses.
- (3) Disconnect the fuel outlet hose from the fuel pump filter.
- (4) Loosen and remove the fuel pump filter from the adapter.
- (5) Remove and discard the O-ring from the fuel pump filter.
- (6) Clean the fuel pump filter per Chapter 05-30.
- (7) Remove the fuel collection container and dispose of the fuel in accordance with environmental regulations.



**Figure 10
Fuel Pump**

B. Fuel Pump Filter Inspection

- (1) Complete the "Fuel Pump Filter Removal" procedure in this chapter.
- (2) Examine the fuel pump filter (Figure 10) for dents, damage, dirt, and contamination.
 - (a) If metal particles are found, identify the source and correct the cause of the problem.
 - (b) If the fuel pump filter is damaged, replace the fuel pump filter.
- (3) Clean the fuel pump filter per instructions in Chapter 05-30.
- (4) Complete the "Fuel Pump Filter Installation" procedure in this chapter.

C. Fuel Pump Filter Installation

⚠ CAUTION DO NOT DAMAGE THE FUEL PUMP FILTER O-RING DURING INSTALLATION. LOSS OF FUEL SYSTEM PRESSURE AND FUEL LEAKAGE COULD OCCUR CREATING A POTENTIAL FIRE HAZARD.

NOTICE: A new O-ring must be installed every time the fuel pump filter is installed. The O-ring must be replaced if the fuel pump filter is re-installed.


- (1) Install the new O-ring (Figure 10) on the fuel pump filter.

- (2) Apply a light coat of engine oil to the new O-ring. Leave the first leading thread free and apply a 360° bead of Loctite® LB-8009™ to the following three to four threads of the fuel pump filter.
- (3) Install a new fuel pump filter or serviceable clean fuel pump filter with the O-ring in the adapter and initially hand-tighten the filter.
- (4) Torque the fuel pump filter to between 40 and 43 ft.-lb. (54 and 58 Nm).
- (5) Connect the fuel outlet hose to the fuel pump filter.
- (6) Install and tighten the bleed cap on the fuel pressure regulator bleed port.

 **CAUTION** DO NOT RETURN THE ENGINE TO SERVICE UNLESS THE ENGINE IS OPERATING CORRECTLY AND DOES NOT HAVE ANY LEAKS.

- (7) Look for any fuel leak. Identify and correct the cause of any fuel leak. There must not be any leak. All fuel connections must be secure and torqued in accordance with the Standard Torque Tables in the latest revision of the *Service Table of Limits - SSP-1776*.
- (8) If a leak or malfunction was found and corrected, operate the engine again to make sure it is operating correctly and there is no leak anywhere.

10. Fuel Pump Replacement

 **WARNING** DO NOT SMOKE OR HAVE AN OPEN FIRE FLAME OR USE ANY DEVICE THAT CAN MAKE SPARKS. FLAMES OR SPARKS CAN CAUSE FUEL IGNITION WHICH CAN CAUSE SERIOUS BURNS, INJURY OR DEATH.

NOTICE: If this fuel pump replacement procedure is completed with the engine installed in the airframe, refer to the airframe manufacturer's instructions for shutting off the fuel and grounding the aircraft.

A. Fuel Pump Removal

- (1) Put a collection container under the engine where the fuel hose connects to the fuel pump inlet (Figure 10).
- (2) Loosen the cap on the fuel pressure regulator bleed port to release pressure from the fuel hoses.
- (3) Disconnect the fuel inlet hose from the 90° elbow on the fuel pump.
- (4) Disconnect the fuel outlet hose from the fuel pump filter.
- (5) Let the fuel drain into the collection container. Remove the collection container. Dispose of the fuel in accordance with environmental regulations.
- (6) Disconnect the harness connector from Fuel Pump Pressure Sensor on the fuel pump outlet.
- (7) Remove four nuts (Figure 10), washers, and lock washers that attach the fuel pump to the accessory drive. Discard the lock washers.
- (8) Remove the fuel pump from the studs on the accessory pad.
- (9) Remove the two gaskets and spacer from the accessory pad. Discard the gaskets.

B. Fuel Pump Installation

⚠ CAUTION DO NOT USE SHARP METAL OBJECTS TO CLEAN GASKET MATERIAL FROM FUEL PUMP MATING SURFACES ON THE ACCESSORY DRIVE AND SPACER. NICKS AND GOUGES COULD RESULT, PREVENTING GASKETS FROM PROVIDING AN ADEQUATE SEAL.

DO NOT DAMAGE THE TWO GASKETS DURING INSTALLATION. A FUEL LEAK CAN OCCUR.

- (1) Clean the fuel pump accessory pad and fuel pump spacer (Figure 10) to make sure that all gasket material has been removed.
- (2) If installing a new fuel pump, remove the 90° elbow, fuel pump filter and pressure sensor adapter, and 1/8 NPT to 1/4 tube from the removed fuel pump, and install these components on the new fuel pump.
- (3) Install two new gaskets with the spacer on the fuel pump mount pad on the studs on the accessory pad as shown in Figure 10.
- (4) Install the fuel pump on the accessory pad studs.
- (5) Install a washer, a new lock washer and a nut on each of the accessory pad studs.
- (6) Torque the nuts to the specified limit in the Standard Torque Tables in the latest revision of the *Service Table of Limits - SSP-1776*.
- (7) Connect the fuel pump inlet supply hose to the 90° elbow on the fuel pump (Figure 10).
- (8) Connect the fuel pump outlet hose to the fuel pump filter.
- (9) Attach the harness connector to the Fuel Pump Pressure Sensor on the fuel pump outlet.
- (10) Install and tighten the bleed cap on the fuel pressure regulator bleed port.

⚠ CAUTION DO NOT RETURN THE ENGINE TO SERVICE UNLESS THE ENGINE IS OPERATING CORRECTLY AND DOES NOT HAVE ANY LEAKS.

- (11) Look for any fuel leak. Identify and correct the cause of any fuel leak. There must not be any leak. All fuel connections must be secure and torqued in accordance with the Standard Torque Tables in the latest revision of the *Service Table of Limits - SSP-1776*.
- (12) If a leak or malfunction was found and corrected, operate the engine again to make sure it is operating correctly and there is no leak anywhere.

11. Fuel Regulator Adapter Manifold Assembly Replacement

⚠ WARNING DO NOT SMOKE OR HAVE AN OPEN FIRE FLAME OR USE ANY DEVICE THAT CAN MAKE SPARKS. FLAMES OR SPARKS CAN CAUSE FUEL IGNITION WHICH CAN CAUSE SERIOUS BURNS, INJURY OR DEATH.

NOTICE: If this fuel regulator adapter manifold assembly replacement procedure is completed with the engine installed in the airframe, refer to the airframe manufacturer's instructions for shutting off the fuel and grounding the aircraft.

A. Fuel Regulator Adapter Manifold Assembly Removal

- (1) Put a fuel collection container under the engine where the fuel hose connects to the fuel manifold return.
- (2) Loosen the bleed cap on the fuel pressure regulator to release pressure from the fuel hoses.
- (3) Remove the pressure source line connected to the inlet nipple on the adapter for the fuel pressure regulator (Figure 11).
- (4) Remove the two screws and washers (that attach the fuel pressure regulator adapter to the fuel manifold).
- (5) Remove the fuel pressure regulator adapter and O-ring. Discard the O-ring.
- (6) Remove the fuel pressure regulator from the fuel manifold.
- (7) Remove the fuel collection container and dispose of the fuel in accordance with environmental regulations.

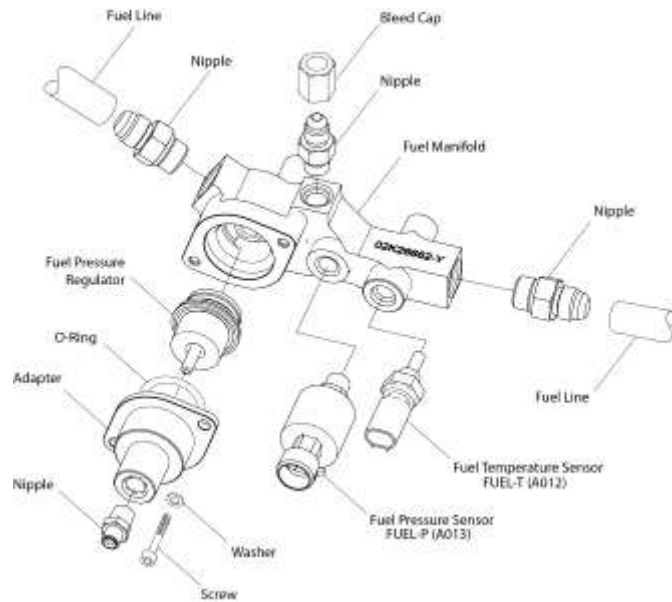


Figure 11
Fuel Regulator Adapter Manifold Assembly

B. Fuel Regulator Adapter Manifold Assembly Installation

⚠ CAUTION DO NOT DAMAGE THE O-RING DURING INSTALLATION OF THE FUEL PRESSURE REGULATOR. LOSS OF FUEL SYSTEM PRESSURE AND FUEL LEAKS COULD OCCUR CREATING A POTENTIAL FIRE HAZARD.

- (1) Install a new O-ring on the adapter (Figure 11).
- (2) Install the adapter on the fuel pressure regulator.
- (3) Install the fuel pressure regulator/adapter on the fuel manifold until the adapter is seated against the mating face of the fuel manifold.
- (4) Install the two screws each with a washer to attach the adapter and fuel pressure regulator to the fuel manifold.
- (5) Torque the screws to the specified limits as per the Standard Torque Tables in the latest revision of the *Service Table of Limits - SSP-1776*.
- (6) Connect the pressure source line to the inlet nipple on the adapter for the fuel pressure regulator.

(7) Install and tighten the bleed cap on the fuel pressure regulator.

⚠ CAUTION: DO NOT RETURN THE ENGINE TO SERVICE UNLESS THE ENGINE IS OPERATING CORRECTLY AND DOES NOT HAVE ANY LEAKS.

(8) Look for any fuel leak. Identify and correct the cause of any fuel leak. There must not be any leak. All fuel connections must be secure and torqued in accordance with the Standard Torque Tables in the latest revision of the *Service Table of Limits - SSP-1776*.

(9) If a leak or malfunction was found and corrected, operate the engine again to make sure it is operating correctly and there is no leak anywhere.

This page intentionally left blank.

73-20 ENGINE FUEL AND CONTROL - CONTROLLING

1. (Electronic) Throttle Body Replacement

NOTICE: A damaged or malfunctioning throttle body cannot be repaired. It must be replaced.

A. (Electronic) Throttle Body Removal

- (1) Disconnect the battery.
- (2) Remove the harness connections from the Throttle Position Sensor (Figure 1) and Delta Pressure Sensor.
- (3) Remove the throttle cable from throttle input lever.
- (4) Remove the two bolts, washers, and lock washers, from the top aft end of the throttle body. Refer to Figure 1. Discard the lock washers.

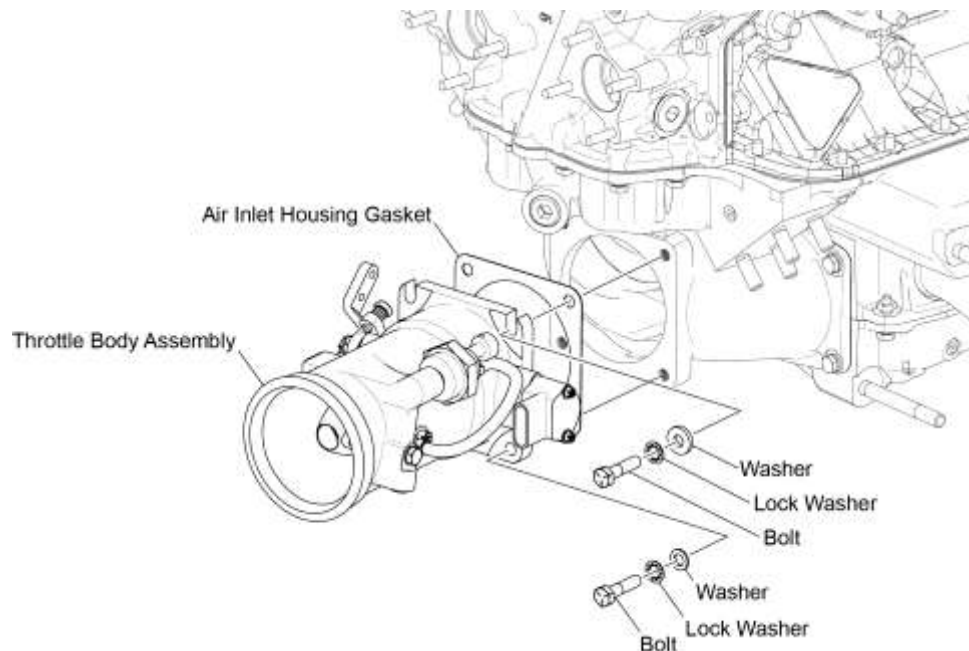


Figure 1
(Electronic) Throttle Body

- (5) Loosen the two bolts, washers, and lock washers, from the top forward end (closest to the engine) of the throttle body. Refer to Figure 1. Discard the lock washers.
- (6) Loosen the two bolts, thick washers, and lock washers, from the bottom aft end of the throttle body. Refer to Figure 1.
- (7) Loosen the two bolts, thick washers, and lock washers from the bottom forward end (closest to the engine) of the throttle body. Refer to Figure 1.
- (8) Lift the throttle body up far enough for the bolt slots to clear the bolts loosened in the previous two steps.
- (9) Remove the throttle body and the bolts, thick washers, and lock washers loosened in the earlier steps. Discard the lock washers.

(10) Label the location of the two gaskets (Figure 1) for reference. Remove and discard the two gaskets, one from each end of the throttle body.

NOTICE: The two gaskets have different part numbers and are specific for each end of the throttle body.

B. (Electronic) Throttle Body Installation

NOTICE: The two gaskets (Figure 1), one on each end of the throttle body have different part numbers and are specific for each end of the throttle body.

- (1) Compare the two new gaskets with the removed gaskets to correctly identify which of the two gaskets to install on each end of the throttle body.
- (2) Install the correct new gasket on each respective end of the throttle body. Install the lower bolts, thick washers (with the washers on the non-mating face of the throttle body flanges), with a new lock washer to hold each gasket in place.
- (3) Install the throttle body, with the throttle input lever on the left side (looking forward), onto the installed four bolts - do not tighten the bolts yet. Make sure that the washers are on the non-mating face of the throttle body flanges.
- (4) Install but do not tighten the upper bolts, washers and new lock washers.
- (5) Make sure each gasket is seated and installed correctly on the throttle body ends.
- (6) Torque all of the bolts to the specified limits in the Standard Torque Tables in the latest revision of the *Service Table of Limits - SSP-1776*.
- (7) Install the throttle cable in the same hole as removed on throttle body input lever.
- (8) Connect the harness connectors to the Throttle Position Sensor and Delta Pressure Sensor.
- (9) Connect the battery.
- (10) Complete the “Operational Test of the Throttle Body” in this chapter to be sure gaskets do not leak.

2. Operational Test of the Throttle Body

- A. Move the power control for a fluid movement.
- B. Make sure that the linkage has the correct amount of play for movement.

74-20 - IGNITION SYSTEM SERVICE

⚠ WARNING FAILURE TO MAINTAIN THE SPARK PLUGS AND IGNITION LEADS CAN CAUSE ENGINE DAMAGE OR FAILURE.

1. Ignition Lead Removal

⚠ WARNING MAKE SURE THE BATTERY HAS BEEN DISCONNECTED FROM THE ENGINE.

NOTICE: As shown in Figure 1, there are two spark plug leads (ignition leads) in each cylinder head. The 12 ignition leads (Figure 2) are identified in Table 1.

A. Open the coil box. Refer to the procedure "Coil Box Access" in Chapter 74-30.

NOTICE: Ignition leads can have different part numbers. Refer to the *TEO-540-A1A Parts Catalog* to identify the correct part number for an ignition lead that is to be replaced. Identify each ignition lead to be removed for reference on assembly.

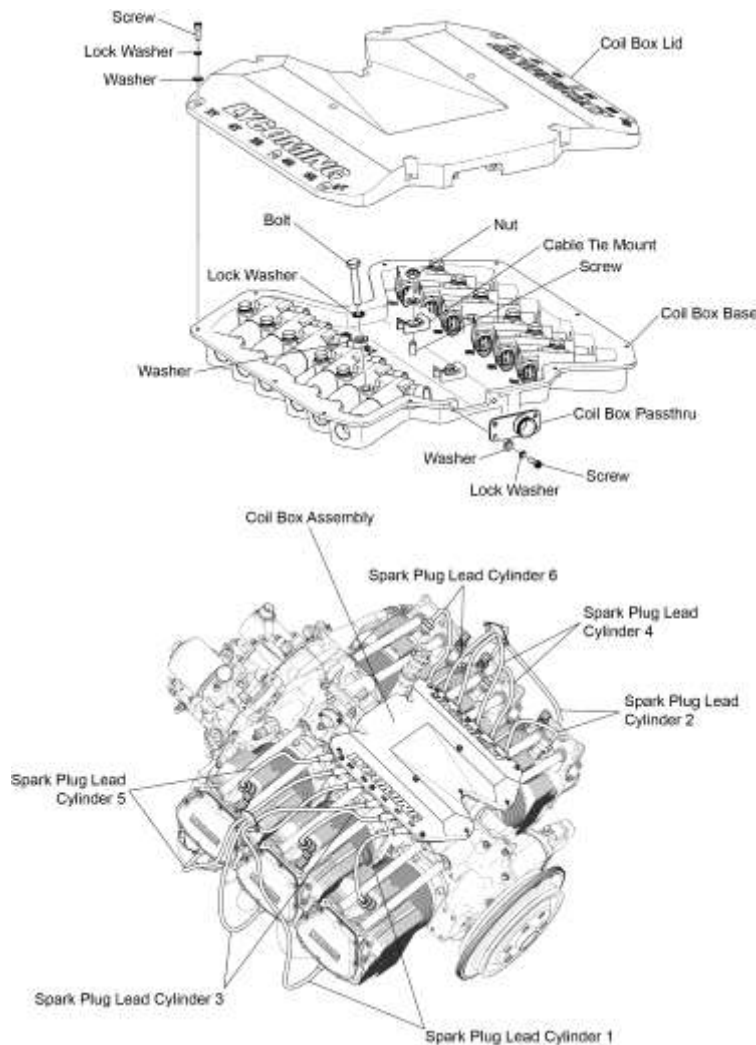


Figure 1
Coil Box

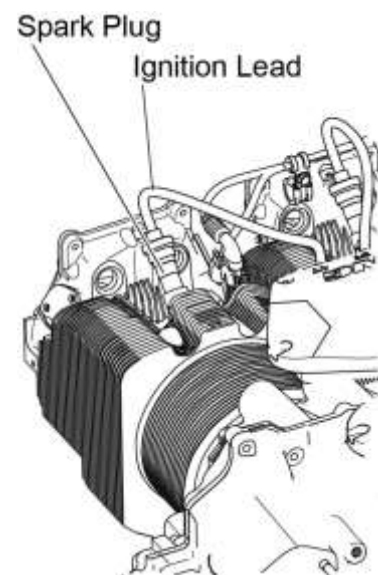


Figure 2
Spark Plug and Ignition Lead

- B. Release any clamps from the ignition lead to be removed.
- C. Disconnect the spark plug connector from the spark plug of the ignition lead to be removed.
- D. Remove the bolt, lock washer, and washer from the coil assembly of the lead to be removed. Discard the lock washer.
- E. Slide the coil assembly horizontally towards the center of the coil box bottom half to let the coil assembly slide out of the silicone seal on the ignition lead. Remove the harness connector from the coil assembly if necessary.

NOTICE: The Spark Plug Wire Nut Special Socket (ST-535) (Figure 3) is used by placing tool with the ignition lead through the open side of the socket so the socket end of the tool can engage on the ignition lead nut (Figure 4).

Use care not to kink or damage the ignition lead when turning the ignition lead nut with the ST-535.

- F. Use the Spark Plug Wire Nut Special Socket (ST-535) to unscrew the ignition lead from the lower half of the coil box.



Figure 3

Spark Plug Wire Nut Special Socket (ST-535)



Figure 4

Ignition Lead Through the Open Side of ST-535

**Table 1
Ignition Leads**

Ignition Lead	ID	Ignition Lead	ID
1T	A065	1B	A066
2T	A072	2B	A071
3T	A067	3B	A068
4T	A074	4B	A073
5T	A069	5B	A070
6T	A076	6B	A075

2. Spark Plugs

Two long reach spark plugs (Figure 5) are installed on each cylinder head (Figure 2) of the engine for a total of 12 spark plugs per engine.

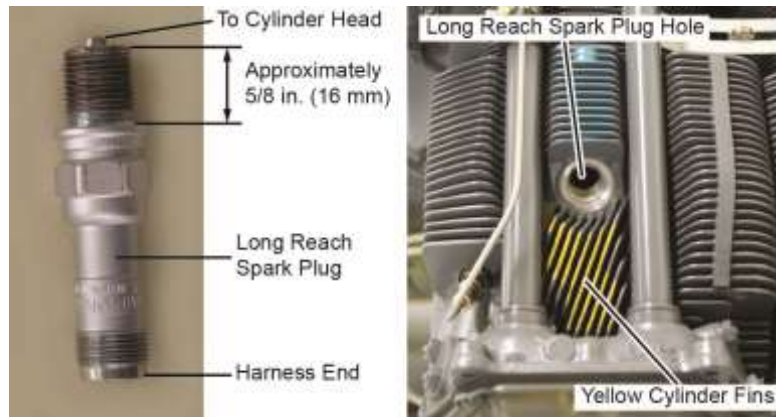


Figure 5
Long Reach Spark Plug & Location

NOTICE: Typically, engines with long reach spark plugs are identified by yellow paint on the cylinder fins between the spark plug hole and the rocker covers where shown in Figure 5.

Refer to the *TEO-540-A1A Illustrated Parts Catalog* to identify the correct spark plug approved for use in these engines.

3. Spark Plug Removal

A. Make sure that the battery is disconnected from the engine.

B. Hold the ferrule and loosen the spark plug nut and disconnect it from the ignition lead.

⚠ CAUTION HOLD FERRULES WHILE LOOSENING THE SPARK PLUG COUPLING NUT TO PREVENT TWISTING THE CONDUIT OR CABLE.

C. Use the applicable sized socket on top of the spark plug and turn the socket to remove the spark plug from the engine cylinder head (Figure 2).

D. Identify by tag or label each spark plug as it is removed, according to cylinder number and top or bottom position.

E. Remove and discard the gasket from the spark plug.

4. Ignition Lead Inspection

NOTICE: The ignition leads are an all-weather, shielded wire constructed with over-braid.

A. Examine spark plug ignition leads (Figures 1 and 2) and spark plug ceramics for corrosion and deposits.

B. Examine each ignition lead for chafing, insulation breakdown, frayed wiring, deterioration, heat damage, wear, and cracking. Replace the harness if any lead shows chafing, cracks, or wear, frayed wiring, or damage.

C. Examine the ignition lead connections. Make sure the ignition lead connections (Table 1) are secure.

D. Make sure the ignition lead mounting clamps are tight.

5. Spark Plug Inspection







NOTICE: Corrosion and deposits are evidence of leaking spark plugs or incorrect cleaning of the spark plugs or connector ends.

A. Remove the spark plug connector nuts.

B. Examine each spark plug and ceramics for chafing, corrosion, wear, and cracking during every inspection. Replace any worn, cracked or corroded spark plug with a new spark plug.

NOTICE: The general guidelines in Table 2 identify acceptable and unacceptable spark plugs. The figures in Table 2 show the condition of the fine wire ground and center electrodes as well as the level of wear indication and condition of the spark plug. Refer to your spark plug manufacturer's manual for specific instructions.

**Table 2
General Spark Plug Wear/Replacement Guidelines**

Spark Plug	Findings	Condition of Fine Wire Ground Electrode on Spark Plug	Condition of Center Electrode on Spark plug	What to do
Acceptable Spark Plugs	Insulator tip gray, tan or light brown No ash deposits Electrodes intact, not burnt or eroded			Clean, set the spark plug gap and install the spark plug per applicable sections in this chapter and in Chapter 05-30.
Partially Worn Spark Plugs	Ash deposits Electrode burnt and/or eroded to less than half of the original thickness More voltage has been necessary to fire the spark plugs			Discard the spark plug and replace with a serviceable spark plug.
Worn Spark Plugs	Erosion of center and ground electrode Extensive necking of the fine wire ground electrode			Look for excessive heat sources. Discard the spark plug and replace with a serviceable spark plug.

C. To be acceptable, the spark plug must not have any of the following:

- (1) Fine wire plugs with loose center or ground electrodes.
- (2) Electrodes that show signs of metal or impact damage.
- (3) Massive electrode plugs with copper run-out of the center electrode.
- (4) Ceramic core nose with a cracked or crazed rough surface.

- D. Measure the spark plug gap (identified by the spark plug manufacturer) to make sure it is at the correct tolerance per the spark plug manufacturer's instruction. Reset the spark plug gap if it is not correct. Refer to the "Spark Plug Gap Setting" procedure in this chapter.
6. Spark Plug Fouling
- A. Lead deposits can collect on the spark plug electrodes when the engine operates at lower-than-specified temperatures with fuel-rich mixtures (fuel-rich mixtures do not enable vaporization of lead in aviation gas). These deposits can cause misfiring.
- B. Recommendations to prevent spark plug fouling:
- If the engine is approved for use with unleaded fuel per Appendix A in the *TEO-540-A1A Engine Installation and Operation Manual*, use unleaded fuel after purging the fuel system.
 - Rotate top and bottom spark plugs every 100 operating hours or annually – refer to the "Spark Plug Rotation" procedure in this chapter.
 - Operate the engine between 1000 and 1200 rpm after engine start and during warm-up. (At these speeds the spark plug core temperatures are sufficiently hot to activate the lead scavenging agents to prevent lead deposits on the spark plugs and exhaust valve stems.)
 - Operate the engine at the specified operating temperature to prevent low temperature operation.
 - Use oil cooler baffles to keep the oil temperature from decreasing during winter flight.
 - Avoid rapid power reduction in flight to prevent sudden engine cooling.
 - Do not stop the engine immediately after landing to prevent rapid engine cooling.
 - Before engine shutdown, operate the engine between 1000 and 1200 rpm until operating temperatures are stable and EGTs drop below 1100°F (593°C). Then increase engine speed to 1800 rpm for 15 to 20 seconds. Then decrease engine speed to between 1000 and 1200 rpm before engine shutdown.

7. Spark Plug Port Seal Inspection

NOTICE: This inspection is usually done to complete the check of the Heli-coil[®] spark plug insert in the cylinder head.

- A. Disconnect the battery and remove the ignitions leads from all spark plugs.
- B. Apply a soap solution to the spark plug seating area of the cylinder head.
- C. Turn the propeller/crankshaft by hand to move the piston, in the cylinder to be inspected, to top dead center of the compression stroke.
- D. Look for bubbles around the spark plug. If bubbles are seen, replace the Heli-coils[®]. Replace all loose or damaged spark plug Heli-coil[®] inserts with oversize inserts per instructions in Chapter 72-30.
- E. Examine the spark plugs (if not already done). Refer to the section "Spark Plug Inspection" procedure in this chapter.
- F. Examine the surface of the cylinder (covered with soap) for cracks. Refer to the "Visual Cylinder Inspection Procedure" in Chapter 72-30.

8. Spark Plug Cleaning

Refer to the spark plug manufacturer’s cleaning instructions.

9. Spark Plug Gap Setting

A. Make sure the “Spark Plug Cleaning” procedure in Chapter 05-30 was completed and that the inside of the spark plug barrel is clean and dry and does not have any residue from cleaning.

NOTICE: Serviceable spark plugs are to be re-installed, otherwise use new replacement long-reach spark plugs per the *TEO-540-A1A Illustrated Parts Catalog*.

B. Before spark plug installation set the spark plug gap in accordance with the spark plug manufacturer’s instructions.

C. Reset and test the spark plugs in accordance with the spark plug manufacturer’s instructions.

10. Spark Plug Rotation

NOTICE: As part of routine service, rotate spark plugs in different locations per Table 3 every 100 hours of engine operation or annually (whichever occurs first) or when there is evidence of spark plug fouling.

A. Remove all of the spark plugs. Refer to the “Spark Plug Removal” procedure in this chapter.

B. Examine each spark plug and ignition lead. Refer to the “Spark Plug Inspection” and “Ignition Lead Inspection” procedures in this chapter.

C. Complete the “Spark Plug Cleaning” procedure in Chapter 05-30.

CAUTION: USE CARE TO PREVENT THE COPPER-BASED ANTI-SEIZE FROM GETTING ON THE SPARK PLUG ELECTRODE OR IN THE COMBUSTION CHAMBER.

DO NOT APPLY A GRAPHITE-BASED COMPOUND TO THE SPARK PLUG THREADS.

D. Apply Copper-Based Anti-Seize (Figure 6) or engine oil to the threads of each spark plug (starting two full threads from the electrode.)



Figure 6
Copper-Based Anti-Seize
Applied to Spark Plug Threads

E. Rotate acceptable spark plugs - move the bottom spark plugs to the upper position; move the upper spark plugs to the bottom position, per the rotation scheme in Table 3.

F. Refer to the “Spark Plug Installation” procedure in this chapter.

Table 3
Spark Plug Rotation Scheme

#1 Top	with	#6 Bottom
#2 Top	with	#5 Bottom
#3 Top	with	#4 Bottom
#4 Top	with	#3 Bottom
#5 Top	with	#2 Bottom
#6 Top	with	#1 Bottom

11. Spark Plug Installation

NOTICE: Complete the “Spark Plug Gap Setting” procedure and as necessary the “Spark Plug Gap Rotation” procedure in this chapter before spark plug installation.

- A. If not already done, apply C5-A Copper-Based Anti-Seize (Figure 6) or engine oil to the threads of each spark plug (starting two full threads from the electrode.)

⚠ CAUTION FAILURE TO INSTALL A NEW SPARK PLUG GASKET ANY TIME A SPARK PLUG IS INSTALLED CAN RESULT IN INCOMPLETE SEALING OF THE COMBUSTION CHAMBER, LOSS OF SPARK PLUG HEAT TRANSFER, SPARK PLUG OVERHEATING, POSSIBLE REIGNITION/DETONATION, AND INTERNAL ENGINE DAMAGE.

⚠ CAUTION NEVER INSTALL A SPARK PLUG THAT HAS BEEN DROPPED ON THE FLOOR.

- B. Install a new spark plug gasket with the spark plug. A new gasket must be installed whether the spark plug is new or is acceptable and being reused.
- C. Install a spark plug in the cylinder top and bottom (Figure 2) according to the manufacturer’s recommendations.
- D. Torque the spark plug to 420 in.-lb. (or 35 ft.-lb.) (47.5 Nm) or per the spark plug manufacturer’s instructions.
- E. Connect the spark plug to the applicable ignition lead per the “Ignition Lead Installation” procedure in this chapter.
- F. Torque the spark plug lead nut to 110 to 120 in.-lb. (12 to 13.6 Nm) or per the spark plug manufacturer’s instructions.

12. Ignition Lead Installation

⚠ WARNING MAKE SURE THE BATTERY HAS BEEN DISCONNECTED FROM THE ENGINE.

NOTICE: If a new ignition lead (Figure 7) is to be installed, refer to the *TEO-540-A1A Illustrated Parts Catalog* to identify the correct part number of the replacement ignition lead.

- A. Examine the ignition leads as per the procedure "Ignition Lead Inspection" in this chapter.

NOTICE: The coil box lid is marked with a letter and number for each ignition lead identifying a spark plug on each respective cylinder. An ignition lead position marked "T1" identifies the top spark plug on cylinder #1 to which that ignition lead is to be connected. An ignition lead position marked "B4" identifies the bottom spark plug on cylinder #4 to which that ignition lead is to be connected.

- B. Apply C5A Copper Based Anti-Seize or equivalent to the threads (Figure 7) on the coil box end of the ignition lead.



Figure 7
Ignition Lead

- C. Install the ignition lead into the lower half of the coil box (Figure 8). Tighten hand tight.

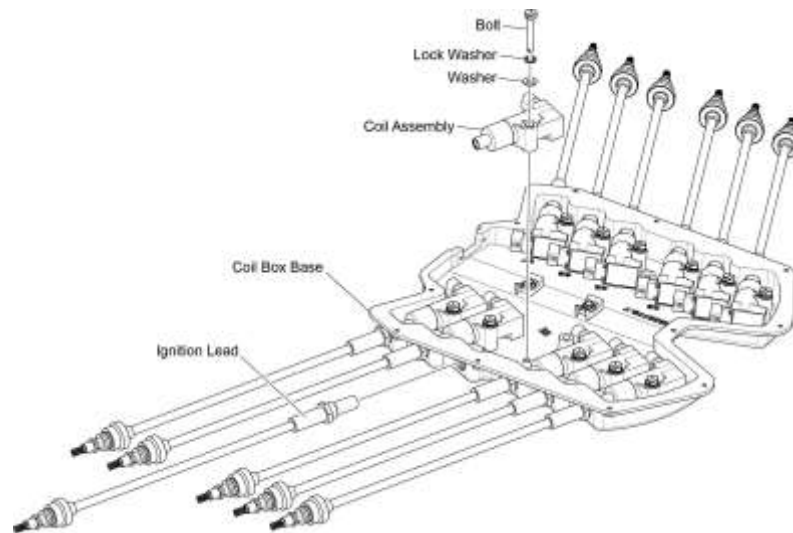



Figure 8
Coil Assembly and Ignition Lead

- D. Apply a light coat of lubricant (petrolatum or DC-4) to the mating surface of the coil assembly.
- E. Install the coil assembly in the lower half of the coil box (Figure 8) and slide it horizontally into the ignition lead.
- F. Install the bolt, new lock washer, and washer to attach the coil assembly to the lower half of the coil box. Torque the bolt to the specified limits in the Standard Torque Tables in the latest revision of the *Service Table of Limits - SSP-1776*.
- G. Apply torque seal to the coil assembly bolt.
- H. Use the Spark Plug Wire Nut Special Socket (ST-535) to torque the nut on the coil box end of the ignition lead (Figure 4) to 60 in.-lb. (6.8 Nm).
- I. Install the coil box lid as per instructions in the "Coil Box Access" section in Chapter 74-30.
- J. Route the ignition leads to the appropriate spark plug position as indicated by the alphanumeric markings on the coil box lid adjacent to each ignition lead.
- K. Attach the spark plug connector end of the ignition lead to the spark plug.
- L. When the spark plug nut thread makes contact with the spark plug threads, push the ferrule against the spark plug while turning the spark plug nut clockwise.
- M. Continue rotating the spark plug nut until it seats and is finger-tight, then tighten the spark plug nut one additional flat.
- N. Install the ignition lead into the clamp and secure the clamp.
- O. Make sure the ignition lead connections are secure. Tighten the leads of any loose connections.
- P. Make sure the ignition lead mounting clamps are tight.
- Q. Make sure there are no kinks or bends in the ignition lead routing.
- R. Close the coil box per the procedure in Chapter 74-30.

74-30 - COIL ASSEMBLY AND COIL BOX MAINTENANCE

1. Coil Box Access

 WARNING MAKE SURE THE BATTERY HAS BEEN DISCONNECTED FROM THE ENGINE.

A. To Open the Coil Box:

- (1) Remove the 15 screws, washers, and lock washers (Figure 1) from the coil box lid. Discard the lock washers.
- (2) Remove the two nuts and washers from the coil box lid.
- (3) Remove the coil box lid.

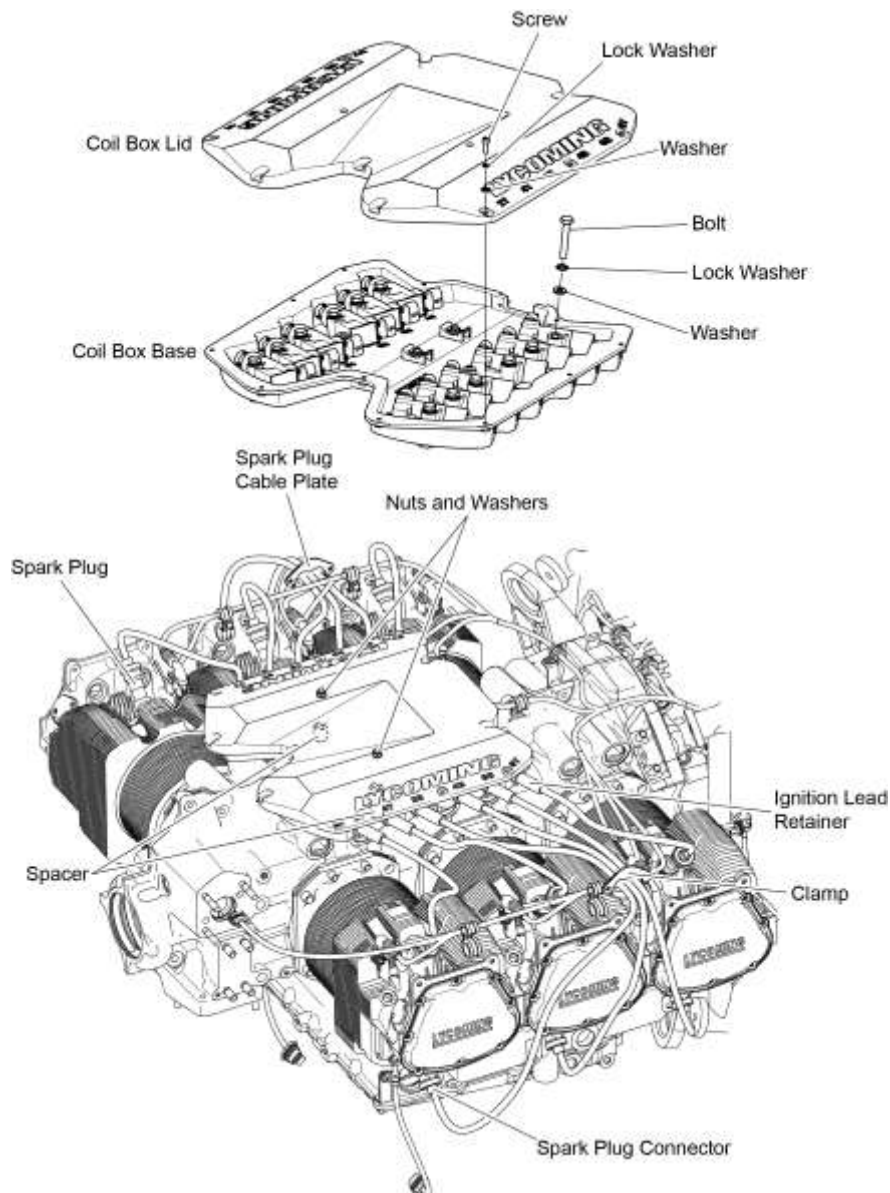


Figure 1
Coil Box

B. To Close the Coil Box:

⚠ CAUTION MAKE SURE BEFORE CLOSING THE COIL BOX THAT THERE IS NO FOREIGN OBJECT DEBRIS (FOD). REMOVE ALL FOD FROM THE COIL BOX.

NOTICE: Make sure all bolts (Figure 2) are correctly torqued and all ignition leads are secured before installing the coil box lid.

- (1) Install the coil box lid (Figure 1) with two nuts and washers and 15 screws each with a washer and new lock washer.
- (2) Torque the screws and nuts to the specified torque limits in the Standard Torque Tables in the latest revision of the *Service Table of Limits - SSP-1776*.

2. Coil Assembly Replacement

A. Coil Assembly Removal

⚠ WARNING MAKE SURE THE BATTERY HAS BEEN DISCONNECTED FROM THE ENGINE.

- (1) Remove coil box lid per instructions in the “Coil Box Access” section in this chapter.
- (2) Remove the harness connector from the coil assembly.
- (3) Remove the bolt, lock washer, and washer (Figure 2) from the coil assembly to be removed. Discard the lock washer.
- (4) Slide the coil assembly horizontally towards the center of the coil box bottom half to let the coil assembly slide out of the silicone seal on the ignition lead.

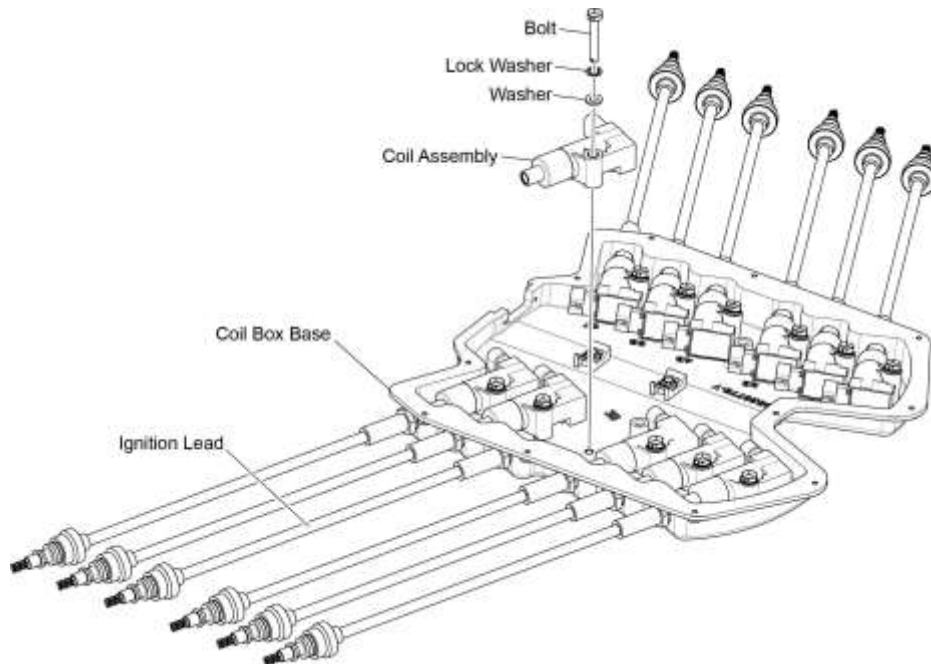


Figure 2
Coil Box Base

B. Coil Assembly Installation

⚠ WARNING MAKE SURE THE BATTERY HAS BEEN DISCONNECTED FROM THE ENGINE.

- (1) Apply a light coat of lubricant (petrolatum or DC-4) to the mating surface of the coil assembly.
- (2) Install the coil assembly in the coil box base (Figure 2) and slide it horizontally into the silicone seal on the ignition lead.
- (3) Install the bolt, new lock washer, and washer to attach the coil assembly to the lower half of the coil box. Torque the bolt to the specified limits in the Standard Torque Tables in the latest revision of the *Service Table of Limits - SSP-1776*.
- (4) Install the harness connector to the coil assembly.
- (5) Install the coil box lid per instructions in the “Close the Coil Box” section in this chapter.
- (6) Connect the battery.
- (7) Complete the operational test in Chapter 72-00.

3. Coil Box Removal

⚠ WARNING MAKE SURE THE BATTERY HAS BEEN DISCONNECTED FROM THE ENGINE.

- A. Remove coil box lid per instructions in the “Open the Coil Box” section in this chapter.
- B. Release the clamps (Figure 1) that hold the spark plug wires.
- C. Disconnect the ignition lead spark plug connector from all top and bottom spark plugs.
- D. Feed the ignition leads where they are near the lower half of the coil box.
- E. Label and disconnect 12 harness connectors from the 12 coil assemblies.
- F. Cut and remove the tie-wraps that attach the engine harness to clamp bases on the coil box base.
- G. Remove the four screws, lock washers, and washers from the coil box pass thru plate (Figure 3). Discard the lock washers.
- H. While lifting engine harness and pass thru plate, lift the coil box base clear of the mounting studs and remove the coil box. Make sure that the spacers stay on the coil box mounting studs.

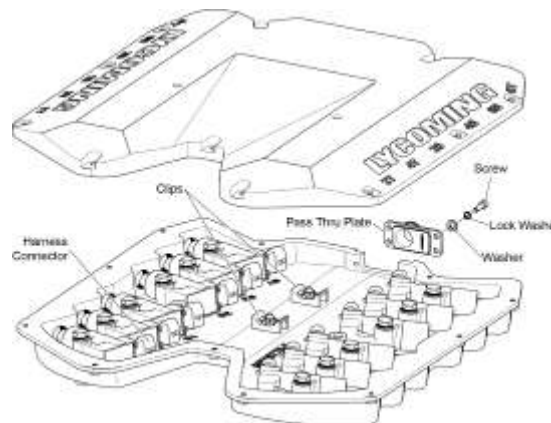


Figure 3
Coil Box Detail


4. Coil Box Installation

 **WARNING** MAKE SURE THE BATTERY HAS BEEN DISCONNECTED FROM THE ENGINE.

- A. Make sure the spacers (Figure 1) are installed on the coil box mounting studs.
- B. Lift the engine harness and pass thru plate (Figure 3) and put the lower half of the coil box on the mounting studs.
- C. Install the engine harness and pass thru plate on the coil box base with the four screws, new lock washers, and washers.

NOTICE: The harness connectors are identified for their respective coil assemblies.

- D. Connect the 12 harness connectors to the respective 12 coil assemblies.

 **CAUTION** IN THE NEXT STEP, DO NOT PUT THE HARNESS DIRECTLY ON THE SCREW IN THE COIL BOX HARNESS CLIP. ATTACH THE HARNESS SECURELY TO ONE LOOP ON THE CLAMP BASE.

- E. Use ignition lead tie-wraps to attach the harness to the clamp bases on the coil box base.
- F. Make sure the ignition leads are not kinked, cracked, damaged or frayed.
- G. Route the ignition leads to the corresponding spark plugs per instructions in Chapter 74-20.
- H. Connect the ignition lead spark plug connectors to the corresponding spark plugs.

NOTICE: Make sure all bolts (Figure 2) are correctly torqued and all ignition leads are secured before installing the coil box lid.

- I. Install the coil box lid per instructions in the “Close the Coil Box” section in this chapter.
- J. Install the ignition leads into the clamp from which they were removed. Secure the clamp.
- K. Connect the battery.
- L. Complete the operational ground check in Chapter 72-00.

78-00 - EXHAUST SYSTEM MAINTENANCE

1. Heat Shield Removal

- A. Loosen both of the hose clamps (Figure 1).
- B. Remove the five screws and five washers (three on top and two on bottom) that attach the outer heat shield to the inner heat shield.
- C. Remove the hose clamps to release the inner heat shield.

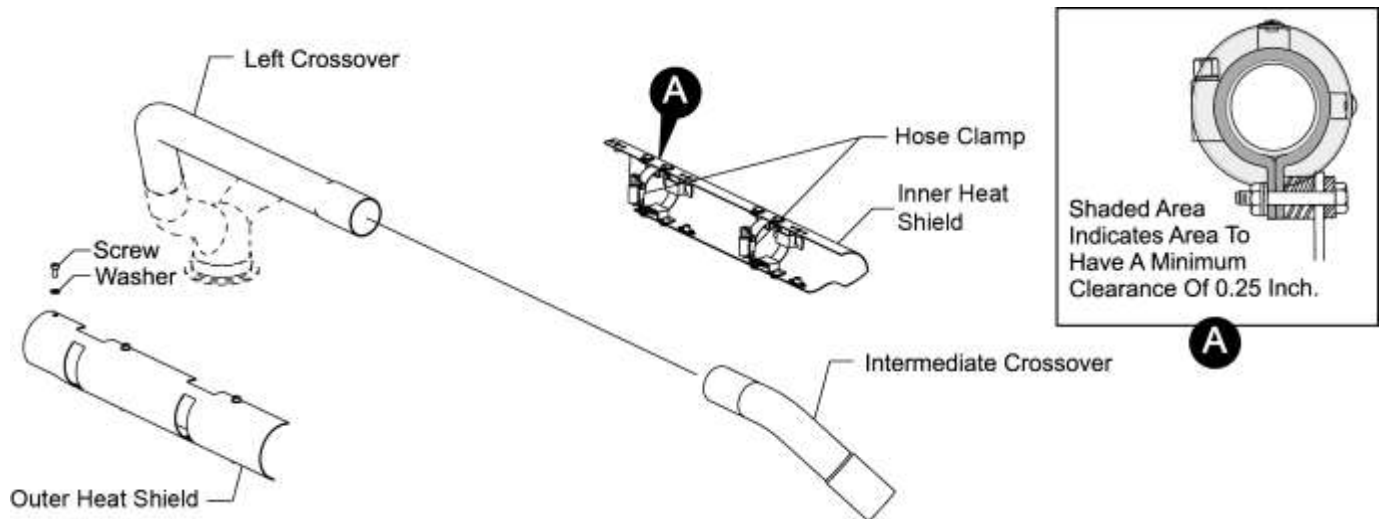


Figure 1
Removal of Heat Shield

⚠ CAUTION DO NOT MARK THE EXHAUST PIPE WITH A GRAPHITE LEAD PENCIL OR SCRIBE. A CHEMICAL REACTION WILL OCCUR BETWEEN THE GRAPHITE LEAD AND THE STAINLESS STEEL. USE A NON-GRAPHITE MARKER SUCH AS COLORBRITE NOS. 2127, 4127, OR MARKS-A-LOT.

NOTICE: During the 250-Hour Exhaust System Inspection (in this chapter) or anytime the exhaust system is removed, mark the exhaust pipe in accordance with Figure 2. You will use the marks to measure the slip joint engagement.

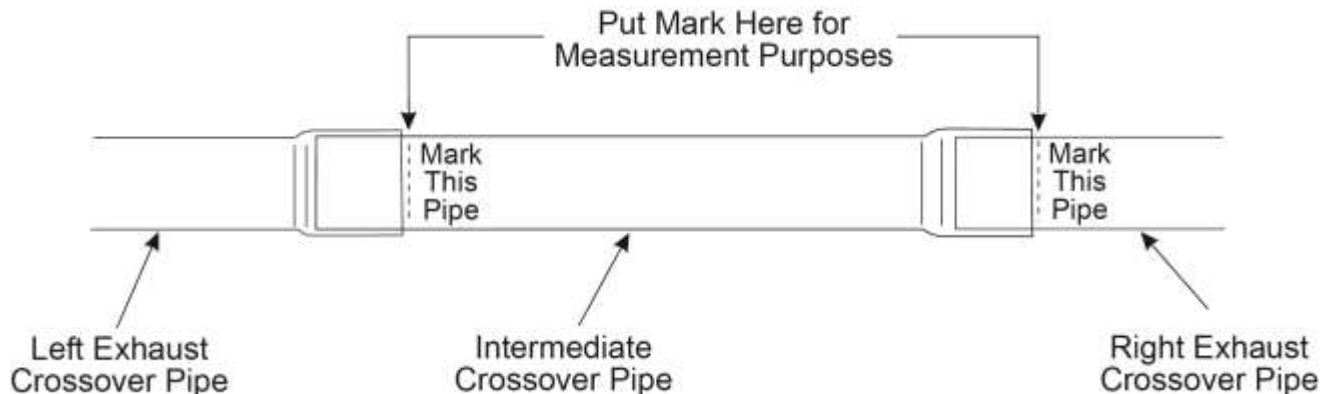


Figure 2
Marking Exhaust Pipes to Measure Engagement

2. 50-Hour Exhaust System Inspection

NOTICE: Complete this inspection after every 50 hours of engine operation.

- A. Examine the transition (Figure 3) and its gaskets and clamps as well as the slip joints (Figure 4) for cracks, and poor or loose fittings. Identify and correct any problems. Replace any damaged, leaky gaskets.

NOTICE: Cracks can be caused by excessively high Exhaust Gas Temperature (EGT) or Turbine Inlet Temperature (TIT). Identify the cause of high EGT or TIT temperature if suspected. Exhaust gas temperature and turbine inlet temperature must not exceed the maximum temperature limit during operation per Appendix A in the *TEO-540-A1A Engine Installation and Operation Manual*.

- B. Look for leaks in exhaust system connections and exhaust ports of cylinders. If exhaust system leaks are suspected, look for paint burned off around spark plugs and exhaust flange bosses. Also, look for light gray deposits on surfaces near the leak.
- C. Examine the exhaust system for a powdery white to light brown or black residue which is evidence of exhaust gas leakage. Identify and correct the cause of the leakage.
- D. Torque any loosened gasketed flange assemblies in accordance with the Standard Torque Tables in the latest revision of the *Service Table of Limits - SSP-1776*. Complete a check if this tightening stopped the leak.
- E. Look for loose heat shields. Tighten fasteners on loose heat shields.
- F. Examine the exhaust manifolds for visible damage such as bulging, cracks, dents, residue and overall general condition. Identify and correct all of the causes in accordance with the airframe or exhaust manufacturer's procedures.


3. 100-Hour Exhaust System Inspection

NOTICE: Complete this inspection after every 100 hours of engine operation (or during the annual inspection).

- A. Examine hardware torque on exhaust flange assemblies.
- B. Examine the exhaust system gaskets (Figure 3) for damage. Replace a damaged exhaust system gasket.

4. 250-Hour Exhaust System Inspection

NOTICE: Complete this inspection every 250 hours or annually (the first that is applicable).

 **CAUTION** ALL OF THE FLANGE SURFACES MUST BE ACCURATELY ALIGNED. IF CROSSOVER EXHAUST COMPONENTS ARE INCORRECTLY ALIGNED, THEY CAN CAUSE TOO MUCH STRESS TO THE FLANGES OF THE CROSSOVER EXHAUST PIPES (FIGURE 3). THIS MISALIGNMENT ALSO CAN CAUSE GAS LEAKAGE AT THE SLIP JOINTS OF THE INTERMEDIATE CROSSOVER PIPE AND FLANGE JOINTS OF THE LEFT AND RIGHT CROSSOVER PIPES.

- A. Mark the exhaust pipe in accordance with Figure 2. You will use the marks to measure the slip joint engagement.
- B. Examine the flange joint at the transition inlet for deformation and/or cracks.
- C. Examine the exhaust pipe and attachments (Figure 3) for cracks.

- D. Examine the underside of bends for signs of rubbing and/or wear.
- E. Examine the slip joint (Figure 4) components for distortion, cracks, separation, gas leaks, and make sure it is correctly aligned.

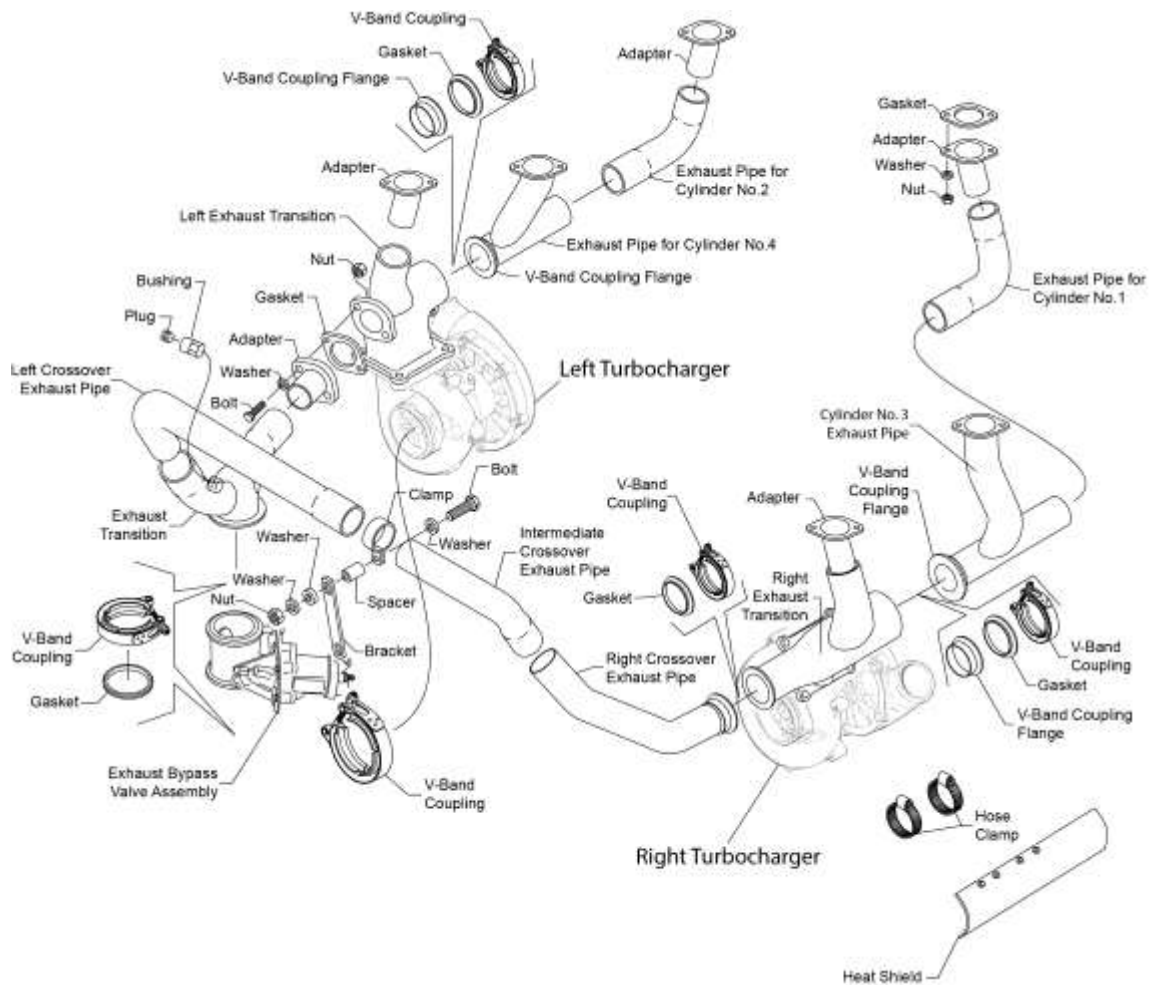


Figure 3
Exhaust System

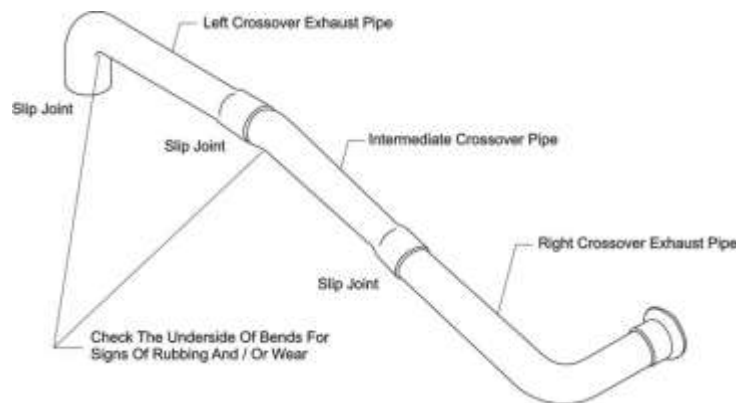


Figure 4
Right Crossover Exhaust Pipe and Left Crossover Exhaust Pipe

- F. To make sure that each exhaust system slip joint is correctly attached, and to examine all of the flange joints at the transition inlet, measure the distance from the mark (made earlier) (Figure 5) to the end of the right exhaust pipe. If this measurement is less than 0.75 in. (1.95 cm), replace the pipe.
- G. Measure from the mark to the end of the intermediate exhaust pipe (Figure 5). If this measurement is less than 0.75 in. (1.95 cm), replace the pipe.

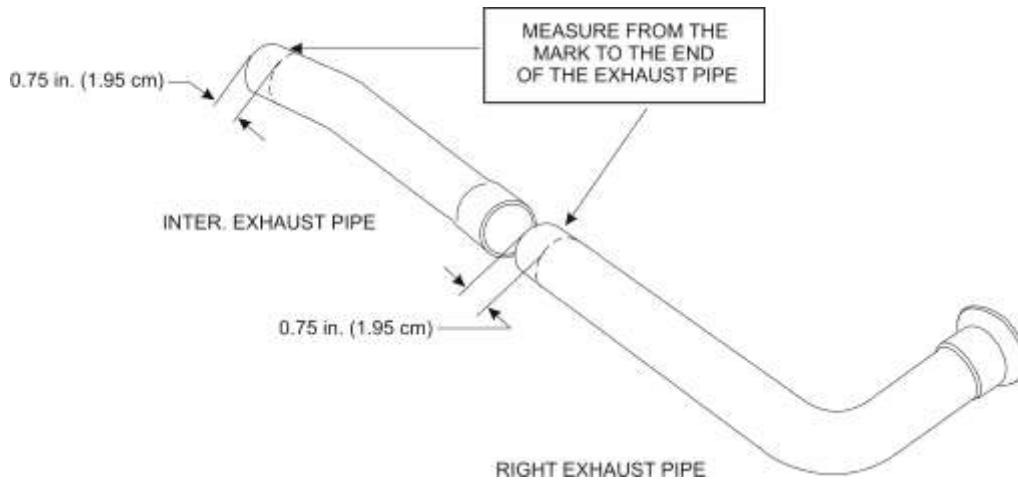


Figure 5
Measuring Engagement of Slip Joints

- H. Examine the flange face and the area inside the flange mouth at the end of the exhaust pipe for cracks and distortion (Figure 6).

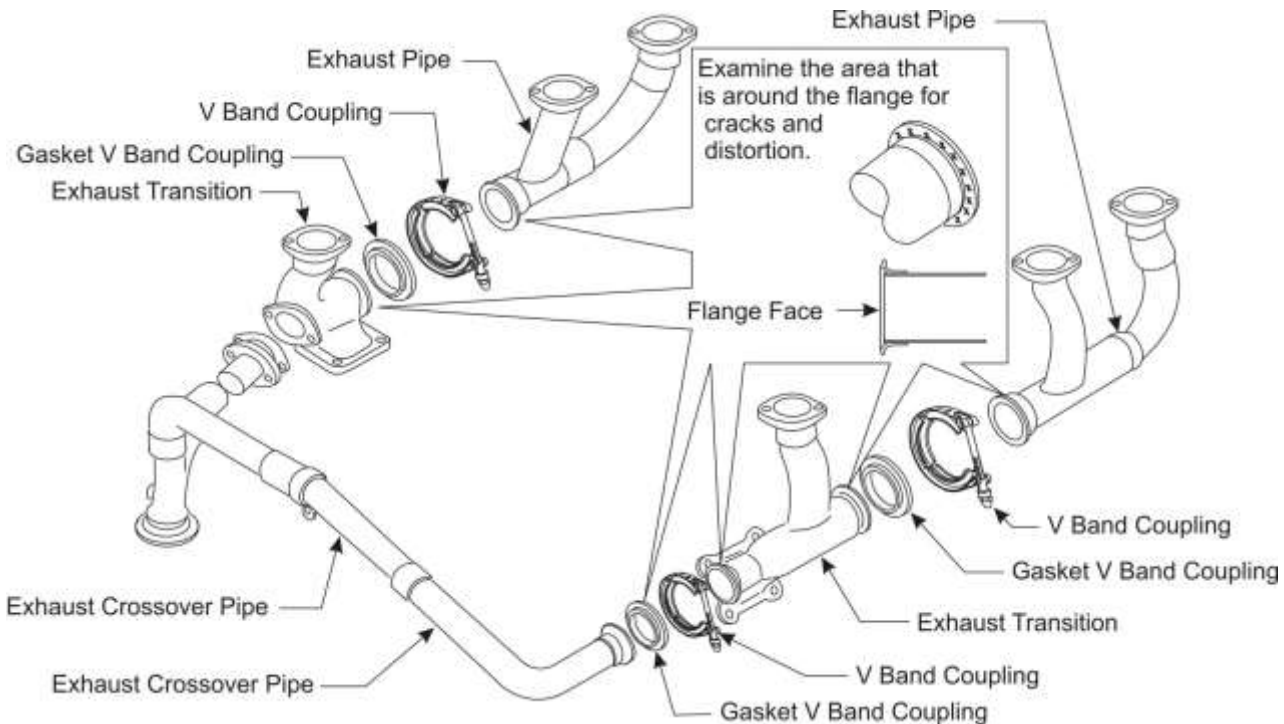


Figure 6
Flange Area Subject to Damage

- I. Examine the exhaust pipe segments that are attached to the exhaust bypass transition assembly (Figure 3). Record all cracks on welds and attaching flanges. Replace cracked components.
- J. Examine the V-band sections of each coupling with a depth micrometer. Refer to Figure 7. Make sure there are no dimensions less than 0.230 in. (5.84 mm) on the V-band parts. If a dimension is less than 0.230 in. (5.84 mm), discard and replace the coupling. Never use the defective coupling again.

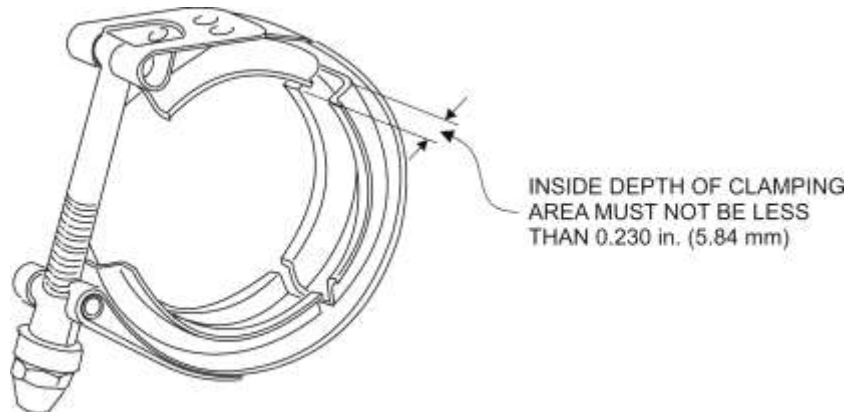


Figure 7
V-Band Coupling Inspection Requirement

5. Heat Shield Installation

- A. Using two hose clamps, install the inner heat shield (Figure 1) over the right exhaust transition (Figure 3) and the right exhaust pipe.
- B. Torque the hose clamps per the Special Torque Requirements Tables in Part 1, Section V in the latest revision of the *Service Table of Limits - SSP-1776*.
- C. Attach the outer heat shield to the inner heat shield with the five screws and five washers (three on top and two on bottom). Torque the screws per the Standard Torque Tables in the latest revision of the *Service Table of Limits - SSP-1776*.

6. Exhaust System Removal

⚠ CAUTION PRIOR TO EXHAUST SYSTEM DISASSEMBLY, LET THE ENGINE AND THE EXHAUST SYSTEM COOL FOR 1 HOUR OR LONGER AFTER ENGINE SHUTDOWN TO PREVENT BURNS. ENSURE THAT THE BATTERY IS DISCONNECTED, TO PREVENT ENGINE START.

NOTICE: If any component of this system is removed or replaced for any reason, loosen all other attachments on that side before installing the component.

- A. To access, the exhaust system, remove any airframe components as necessary per the airframe manufacturer's instructions.
- B. Before disassembly of the exhaust system (for reference on assembly):
 - (1) Apply labels to all exhaust pipes and pieces.
 - (2) Take photos or draw a sketch of the exhaust system as installed and attached to the turbocharger.

⚠ CAUTION DO NOT USE ETCH TOOLS, GRAPHITE LEAD PENCIL, OR SCRIBE TO MARK EXHAUST PIPES. FOR BEST RESULTS, USE A NONGRAPHITE MARKER SUCH AS COLORBRITE NOS. 2127, 4127, OR MARKS-A-LOT.

(3) Identify the locations of V-band couplings, clamps, and adapters.

- C. Disconnect the wiring harness from the Exhaust Gas Temperature (EGT) and Turbine Inlet Temperature (TIT) sensor leads per instructions in the “Sensor Replacement Procedures” section in Chapter 72-70.
- D. Secure the sensor leads with cable ties to prevent damage during disassembly and assembly.
- E. Remove the V-band couplings from both sides of the exhaust transition (Figure 3).
- F. Remove and discard the gasket from each of the removed V-band couplings.
- G. Loosen the clamps on the heat shield (Figure 1) and remove the heat shield at the joint between the right rear exhaust pipe and the intermediate crossover pipe.

⚠ CAUTION AS A SAFETY PRECAUTION, USE THREE PEOPLE TO COMPLETE THE NEXT STEPS TO PREVENT INJURY AND PARTS FROM FALLING.

- H. While one person removes the self-locking nuts and washers (Figure 3) from the vertical portion of the three exhaust pipes on the 2-4-6 (even numbered) cylinder side of the engine, two people lower and remove the exhaust pipes and put them on a clean work surface. Discard the self-locking nuts and gasket from each exhaust pipe flange at the cylinder head.
- I. Repeat the previous step for the three exhaust pipes on the 1-3-5 (odd-numbered) cylinder side of the engine (Figure 3).

7. Exhaust System Installation

⚠ CAUTION CRACKS AS WELL AS INCORRECT ASSEMBLY OR INSTALLATION OF THE EXHAUST SYSTEM CAN ADVERSELY AFFECT ENGINE OPERATION, OR RESULT IN THE RELEASE OF HOT TOXIC GASES WHICH CAN CAUSE A FIRE AS WELL AS DAMAGE TO NEARBY COMPONENTS.

- A. Clean all exhaust pipes between exhaust manifold connections and at all slip joints with a scuff pad. Remove all debris. Make sure the connecting/mating surfaces at slip joints are clean and that there is no residual debris.
- B. Examine all of the exhaust pipes and saddle welds for cracks, bulges, dents, damage, and correct fit. Replace any component that is cracked, bulged, dented, damaged or does not fit correctly.
- C. Apply C5A Copper Based Anti-Seize or equivalent to the threads on the exhaust studs.

NOTICE: Beaded exhaust flange gaskets must be assembled (two each per exhaust port flange) with their beads interlocking (Figure 8). The flat side of the gasket must face toward the cylinder head and the raised or bead side, toward the exhaust stack. (Refer to the latest revision of Service Instruction SI-1204 for exhaust flange gasket information.)

NOTICE: After initial installation of a new beaded exhaust flange gasket, retorque the exhaust flange nuts after the first 25-hours of engine operation to allow for permanent seating of the beads. The beaded exhaust flange gasket cannot be reused. Replace this beaded gasket with a new gasket after each removal.

D. Install two new beaded exhaust flange gaskets to replace the discarded gaskets.

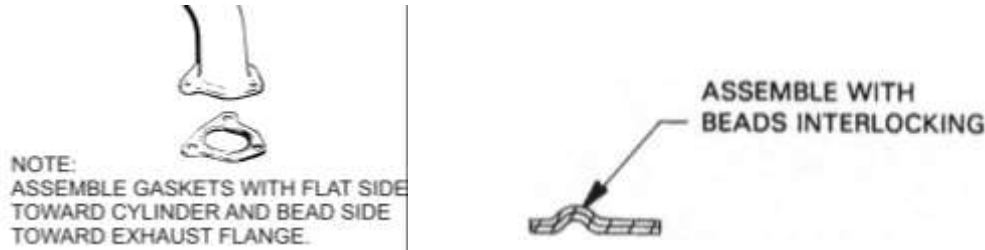


Figure 8
Exhaust Flange Gasket

E. Install the exhaust flange with two new self-locking nuts and washers.

F. Begin assembly of the exhaust system at the front of the engine and continue to the rear of the engine.

NOTICE: Make sure the connecting/mating surfaces at slip joints are clean, and that there is no debris.

G. Apply a uniform coating of C5A Copper Based Anti-Seize or equivalent around the entire circumference of exhaust pipes, between the exhaust manifold connection, and at all slip joints (to minimize binding).

H. Refer to the photo or sketch done before disassembly to ensure correct assembly and installation of the exhaust pipes.

⚠ CAUTION WHEN INSTALLING EXHAUST SYSTEM COMPONENTS, INITIALLY TIGHTEN HARDWARE FASTENERS FINGER-TIGHT. DO NOT TIGHTEN ANY PART OF THE EXHAUST SYSTEM BEFORE PROCEEDING TO ANOTHER PART ON THE SAME SIDE OF THE ENGINE.

I. Install exhaust system parts with hardware fasteners finger-tight to allow for adjustment in the next step.

J. Align exhaust pipes in the correct configuration (per your photo or sketch) to enable engagement of the slip joints at the same distance for each joint. If there is binding at a slip joint or pipes at the V-band coupling are not aligned, loosen and re-install the components until they align correctly.

⚠ CAUTION DURING REPLACEMENT OF ANY EXHAUST PIPE, ALL OF THE FLANGE SURFACES MUST BE ACCURATELY ALIGNED. IF CROSSOVER EXHAUST COMPONENTS ARE INCORRECTLY ALIGNED, THEY CAN CAUSE TOO MUCH STRESS ON THE FLANGES OF THE CROSSOVER EXHAUST PIPES AND CAUSE GAS LEAKAGE AT SLIP JOINTS AND FLANGE JOINTS.

K. If there is a flared end of the exhaust pipe, install the flared end over the smaller end of the connecting exhaust pipe.

⚠ CAUTION DURING V-BAND COUPLING INSTALLATION, USE CARE NOT TO SPREAD OR FORCE THE COUPLING BEYOND ITS NORMAL OPEN POSITION TO PREVENT DISTORTION OF THE COUPLING. THIS DISTORTION CAN CAUSE AN INEFFECTIVE SEAL OR RUPTURE THE METAL WHICH CAN RESULT IN FAILURE OF THE COUPLING.

NOTICE: Every time a V-band coupling is assembled, install a new gasket within the coupling. Make sure that the seal is complete when a V-band coupling is assembled over an exhaust system component. (Refer to the latest revision of Service Instruction SI-1238 for assembly and torque procedures for V-band couplings.)

L. Install the V-band couplings (Figure 3) as follows:

⚠ CAUTION PROPER INSTALLATION IS CRITICAL. TUBES AND COMPONENTS TO BE JOINED MUST BE ALIGNED WITH EACH OTHER BEFORE INSTALLATION OF THE V-BAND COUPLING. FLANGES MUST ALSO BE ALIGNED CORRECTLY WITH ZERO GAP BETWEEN FLANGE FACES PRIOR TO V-BAND COUPLING INSTALLATION TO ENSURE GOOD JOINT PERFORMANCE.

- (1) Slide the V-band coupling with a new gasket over the correct exhaust pipe.
- (2) Point the lip of the new gasket in the direction of the correct exhaust pipe.
- (3) Adjust all of the pipes so the slip joints are engaged at the same distance for each joint.
- (4) With the pipe transition attached, assemble the V-band coupling over both pipes and the gasket.
- (5) Press the V-band coupling on the flanges.
- (6) Engage the T-bolt.
- (7) Use a torque indicator wrench to tighten the different types of coupling nuts approximately 70% of the specified torque values identified below:
 - (a) Split type locknut with a specified torque of 85 in.-lb. (9.6 Nm).
 - (b) Drilled hex nut secured with safety wire, having a specified torque of 75 in.-lb. (8.5 Nm).
- (8) Tap the outer surfaces of the coupling with a rubber mallet to apply equal band tension.

M. Make sure there are no gaps at pipe connections and all pipes are correctly aligned before the final torque of the fasteners.

⚠ CAUTION TORQUE HARDWARE FASTENERS EVENLY AND UNIFORMLY TO PREVENT LEAKS.

- N. Once the alignment and configuration are validated, torque the exhaust flange nuts to 17 ft.-lb. (23 Nm). Torque the hardware fasteners for each attaching component equally and uniformly on each side, one component at a time per the Standard Torque Tables in the latest revision of the *Service Table of Limits - SSP-1776*.
- O. Install the heat shield at the joint between the right rear exhaust pipe and the intermediate crossover pipe with two clamps.
- P. Torque the clamps of the heat shield per the Special Torque Requirements Tables in Part 1, Section V in the latest revision of the *Service Table of Limits - SSP-1776*.

8. Intercooler Replacement

NOTICE: There are two different part numbers for the left and right intercoolers. Refer to the TEO-540-A1A Illustrated Parts Catalog for the correct part number of the intercooler to be installed/replaced.

A. Intercooler Removal

- (1) Loosen the bolt (Figure 9) on the two hose clamps on each of the two hoses (all part numbers are the same) attached to the top and bottom of either the left or right intercooler
- (2) Disconnect the intercooler from the hoses and remove the intercooler.

B. Intercooler Installation

NOTICE: There are two different part numbers for the left and right intercooler. Be sure to install the correct intercooler (left or right). Refer to the *TEO-540-A1A Illustrated Parts Catalog* for the correct part number of the intercooler to be installed/replaced.

If it is necessary to install any intercooler fittings, apply Loctite[®] 564 thread sealant or equivalent to pipe threads and engine oil mixture to standard threads.

- (1) Install the correct (left or right) intercooler between the two hoses (Figure 9).
- (2) Make sure each hose is securely attached to the intercooler.
- (3) Attach the two hose clamps on each of the two hoses (all part numbers are the same) attached to the top and bottom of either the left or right intercooler. Tighten the bolt securely on the hose clamps.

9. Turbocharger-to-Intercooler Pipe Replacement

NOTICE: There are two different part numbers for the left and right turbocharger-to-intercooler pipes. Refer to the *TEO-540-A1A Illustrated Parts Catalog* for the correct part number of the turbocharger-to-intercooler pipe to be installed/replaced.

A. Turbocharger-to-Intercooler Pipe Removal

- (1) Remove the clamp and spacer (Figure 9) on the clamp of the turbocharger-to-intercooler pipe to be removed. (There are different part numbers for the left and right spacers. The clamp part number is the same for both sides.) If both turbocharger-to-intercooler pipes are to be removed, identify which side the spacer was on for reference on assembly.
- (2) Loosen the bolt (Figure 9) on the two hose clamps on the hose (all part numbers are the same) installed between the intercooler and turbocharger -to-intercooler pipe.
- (3) Loosen the bolt on the two hose clamps on the hose (all part numbers are the same) installed between the turbocharger and the turbocharger -to-intercooler pipe.
- (4) Disconnect and remove the turbocharger -to-intercooler pipe from the two hose segments.

B. Turbocharger-to-Intercooler Pipe Installation

NOTICE: There are two different part numbers for the left and right turbocharger-to-intercooler pipes. Be sure to install the correct turbocharger-to-intercooler pipe (left/right). Refer to the *TEO-540-A1A Illustrated Parts Catalog* for the correct part number of the turbocharger-to-intercooler pipe to be installed/replaced.

- (1) Install the correct (left or right) turbocharger-to-intercooler pipe between the two hoses (Figure 9). (One hose attaches to the intercooler and the other hose attaches the turbocharger.)
- (2) Make sure each hose is securely attached to the turbocharger-to-intercooler pipe.
- (3) Attach the two hose clamps on each of the two hoses (all part numbers are the same) on either the left or right turbocharger-to-intercooler pipe). Tighten the bolt securely on the hose clamps.
- (4) Install the cushion-type clamp on the turbocharger-to-intercooler pipe with the correct spacer.

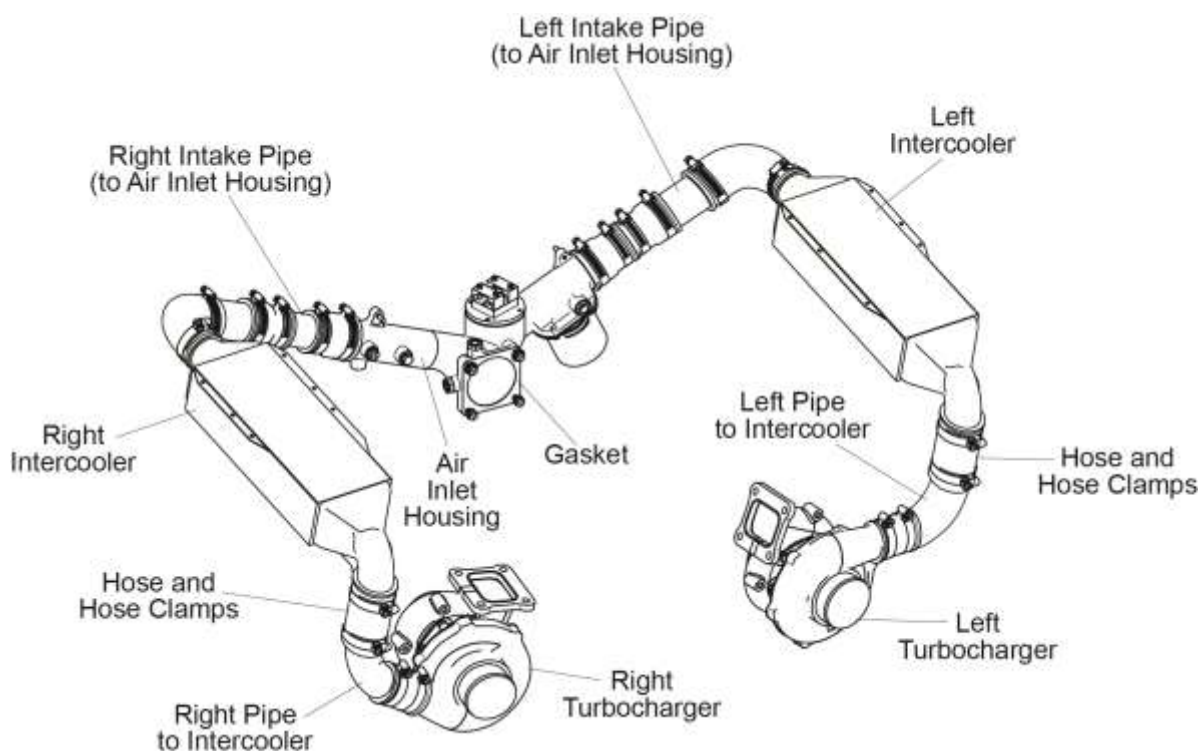


Figure 9
Left/Right Intercoolers and Left/Right Turbocharger to Intercooler Pipes

APPENDIX A

Stud Replacement

NOTICE: This procedure applies to crankcase, accessory housing, and oil sump studs and does not apply to crankcase **thru-studs**.

The procedure for replacement of studs depends on the type of stud and how it was damaged.

1. Replace all studs that are bent, broken, damaged, loose, rusted, corroded, or cannot be cleaned.
2. To remove and replace a damaged stud (Figure A-1):



Figure A-1
Damaged Studs



Figure A-2
Stud Removal Tool

- A. If the stud has sufficient thread area, use a Stud Removal Tool (Figure A-2). Refer to the tool manufacturer's instructions.
- B. If you cannot use a Stud Removal Tool or if the stud is broken beneath the surface:
 - (1) Drill a small hole in the stud.
 - (2) Use a pilot bushing to guide the drill into the center of the stud.
 - (3) Drill again to adjust the size of the hole to the necessary extractor.
 - (4) Remove the stud with the extractor.
- C. After stud removal, examine the size and condition of the threads in the stud holes. If the stud holes are stripped or galled, replace the component or contact Lycoming Engines' Technical Support.
- D. If necessary, replace the regular size studs with oversize studs.
- E. Apply a layer Loctite® Food-Grade Anti-Seize to the threads on the new stud.
- F. Drive the new stud to the correct depth with an applicable stud driver. Refer to the minimum drive torque in the latest revision of the *Service Table of Limits - SSP-1776*.

Air Bleed Nozzle Installation

Install the air bleed nozzles in the upper side of the cylinder head so that the identification mark (a letter or figure location on the 0.500 inch hex) is installed toward the bottom of the engine within approximately one hex flat of 60 in.-lbs. (6.7 Nm).

Fin Stabilizer Installation

NOTICE: Two different widths of fin stabilizers, 0.63 in. (16.00 mm) and 0.31 in. (7.87 mm) are to be installed on each engine cylinder in the locations shown in Figure A-3.

1. Clean the fin stabilizers and cylinder fin areas with mineral spirits or equivalent to remove all grease, dirt, and other unwanted materials.
2. Use compressed air to dry the stabilizers and fins.
3. Apply Dow Corning® Silastic® 140 adhesive to the cylinder fins (Figure A-4).
4. Install the fin stabilizers in the locations shown in Figure A-5.

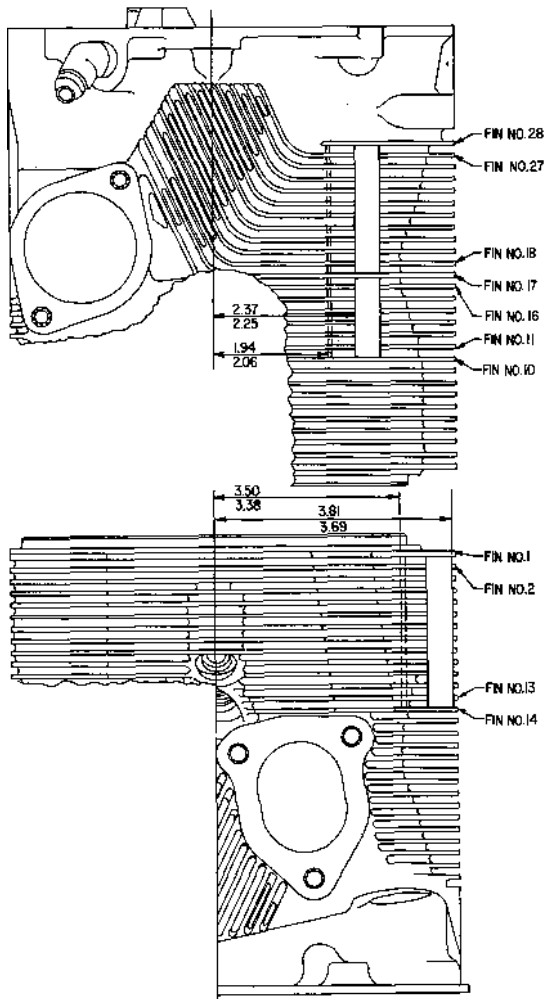


Figure A-3
Fin Stabilizer Locations



Figure A-4
Apply Adhesive



Figure A-5
Fin Stabilizer Installed on Cylinder

APPENDIX B
WIRING DIAGRAMS

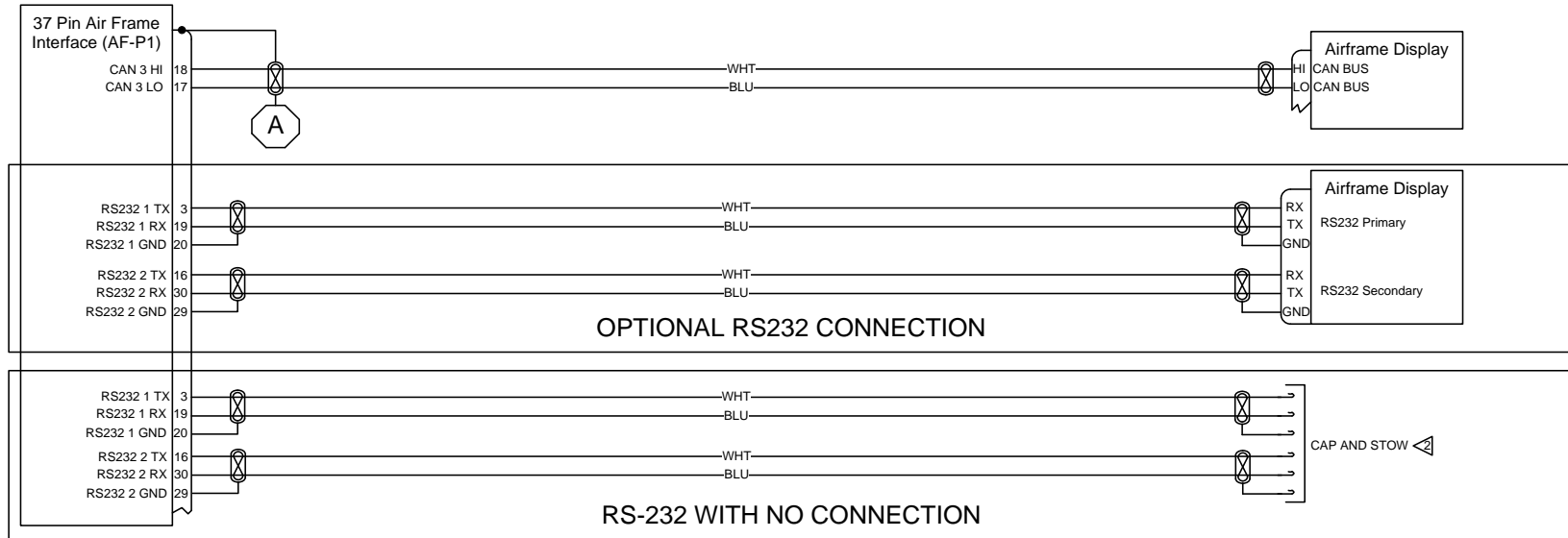
Table B-1 identifies the wiring harness leads and connection location for this engine.

Table B-1
Wiring Harness Leads and Connection Location

Wiring Harness Connector I.D. #	Description	Wiring Harness Connector I.D. #	Description
A066	Coil #1 Bottom	A014	Fuel Pump Pressure
A065	Coil #1 Top	A013	Fuel Rail Pressure
A071	Coil #2 Bottom	A012	Fuel Manifold Temperature
A072	Coil #2 Top		Connector Plug, Firewall
A068	Coil #3 Bottom		Connector Plug, Firewall
A067	Coil #3 Top		Connector Plug, Firewall
A073	Coil #4 Bottom		Connector Plug, Firewall
A074	Coil #4 Top	A005	Fuel Injector (Cylinder #1)
A070	Coil #5 Bottom	A006	Fuel Injector (Cylinder #2)
A069	Coil #5 Top	A007	Fuel Injector (Cylinder #3)
A075	Coil #6 Bottom	A008	Fuel Injector (Cylinder #4)
A076	Coil #6 Top	A009	Fuel Injector (Cylinder #5)
A004	Camshaft Speed	A010	Fuel Injector (Cylinder #6)
A087	Cylinder Head Temperature #1	A016	Knock (Cylinder #1)
A088	Cylinder Head Temperature #2	A015	Knock (Cylinder #2)
A089	Cylinder Head Temperature #3	A018	Knock (Cylinder #3)
A090	Cylinder Head Temperature #4	A019	Knock (Cylinder #4)
A091	Cylinder Head Temperature #5	A020	Knock (Cylinder #5)
A092	Cylinder Head Temperature #6	A017	Knock (Cylinder #6)
A037	Comp Inlet Pressure, Pri.	A040	Manifold Air Pressure
A038	Comp Inlet Pressure, Sec.	A035	Induction Air Manifold Temperature, Primary
A003	Crankshaft Speed		
A045	Induction Deck Pressure, Pri.	A042	Induction Air Manifold Temperature, Secondary
A036	Induction Deck Pressure, Sec.		
A041	Induction Air Deck Temp.	A039	Induction Delta Pressure (Throttle Body)
E70	Harness Ground		
E54	Harness Ground		

**Table B-1 (Cont.)
Wiring Harness Leads and Connection Location**

Wiring Harness Connector I.D. #	Description	Wiring Harness Connector I.D. #	Description
A080	Exhaust Gas Temperature (Cyl #1)	A085	Exhaust Gas Temperature (Cyl #6)
A081	Exhaust Gas Temperature (Cyl #2)	A025	Oil Pressure
		A026	Oil Temperature
A082	Exhaust Gas Temperature (Cyl #3)	A110	Permanent Magnet Alternator
A083	Exhaust Gas Temperature (Cyl #4)	A050	Prop Governor
		A093	Turbine Inlet Temperature
A084	Exhaust Gas Temperature (Cyl #5)	A043	Throttle Position
		A011	Wastegate Control



Notes:

1 All Wires are 22 AWG unless other wise noted.

◁ Airframe manufacturer to add desired connectors.

Figure B-2
Communications Buses

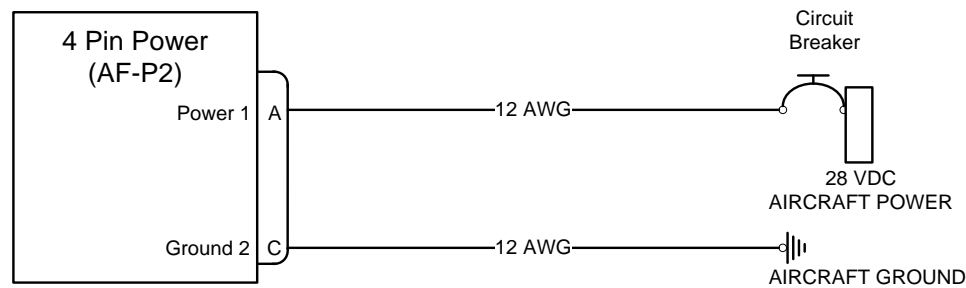


Figure B-3
Volt Power System Connection

PARTS LIST							
QUANTITY		MFG	PART NUMBER	DESCRIPTION	SPEC	NOTES	FN
QTY	TOTAL						
		LYCOMING		WIRING DIAGRAM			1
1	1	LYCOMING	T-11680-Y	WIRING HARNESS-FIREWALL TO ECU/POWERBOX			2
1	1	LYCOMING	T-11277-Y	CABLE HARNESS ASSEMBLY, W2, W3, W4			3
1	1	LYCOMING	60B26321-Y	UNIT, ENGINE CONTROL, ECU (A001)			4
1	1	LYCOMING	60B26322-Y	UNIT, POWER BOX (A002)			5
-	-	-	-	DELETED			6
1	1	LYCOMING	02L26305-Y	VALVE, SOLENOID, 2-WAY (A011)			7
3	3	LYCOMING	60C26307-Y	SENSOR, AIR TEMPERATURE (A035, A041, A042)			8
6	6	LYCOMING	60C26313-Y	SENSOR, CYLINDER HEAD TEMPERATURE (A087 - A092)			9
6	6	LYCOMING	60C26314-Y	SENSOR, EXHAUST GAS TEMPERATURE (A080 - A085)			10
1	1	LYCOMING	60C26763-Y	SENSOR, TURBINE INLET TEMPERATURE, 90° PROBE (A093)			11
2	2	LYCOMING	60C26310-CT-Y	SENSOR, FLUID TEMPERATURE (A012, A026)			12
2	2	LYCOMING	60D26318-CT-Y	SENSOR, POSITION, CAM & CRANK (A003, A004)			13
1	REF	LYCOMING	60D26319-CT-Y	SENSOR, THROTTLE POSITION (A043)		6	14
1	1	LYCOMING	60E26308-CT-Y	SENSOR, PRESSURE, 1 BAR (A037, A038)			15
2	2	LYCOMING	60E26309-CT-Y	SENSOR, PRESSURE, 2 BAR (A036, A045)			16
2	2	LYCOMING	60E26311-CT-Y	SENSOR, TRANSDUCER, PRESSURE, 100 PSIA (A013, A014)			17
1	1	LYCOMING	60E26312-CT-Y	SENSOR, TRANSDUCER, PRESSURE, 150 PSIG (A025)			18
1	REF	LYCOMING	60E26316-CT-Y	SENSOR, TRANSDUCER, LOW PRESSURE (A039)		6	19
6	6	LYCOMING	60F26317-CT-Y	SENSOR, DETONATION (A015 - A020)			20
6	6	LYCOMING	61X26294-CT-Y	INJECTOR, FUEL (A005 - A010)			21
1	1	LYCOMING	32T23324-Y	ALTERNATOR, PERMANENT MAGNET (A110)			22
1	1	LYCOMING	60E26661-CT-Y	SENSOR, TRANSDUCER, PRESSURE, 30 PSIA (A040)			23
12	12	LYCOMING	60B26349-Y	ASSEMBLY, IGNITION COIL (A065 - A075)			24
1	1	LYCOMING	20K26560-Y	GOVERNOR, PROPELLER, ELECTRONIC (A050)			25

Figure B-4
Schematic T-11327-Y (Sheet 1)

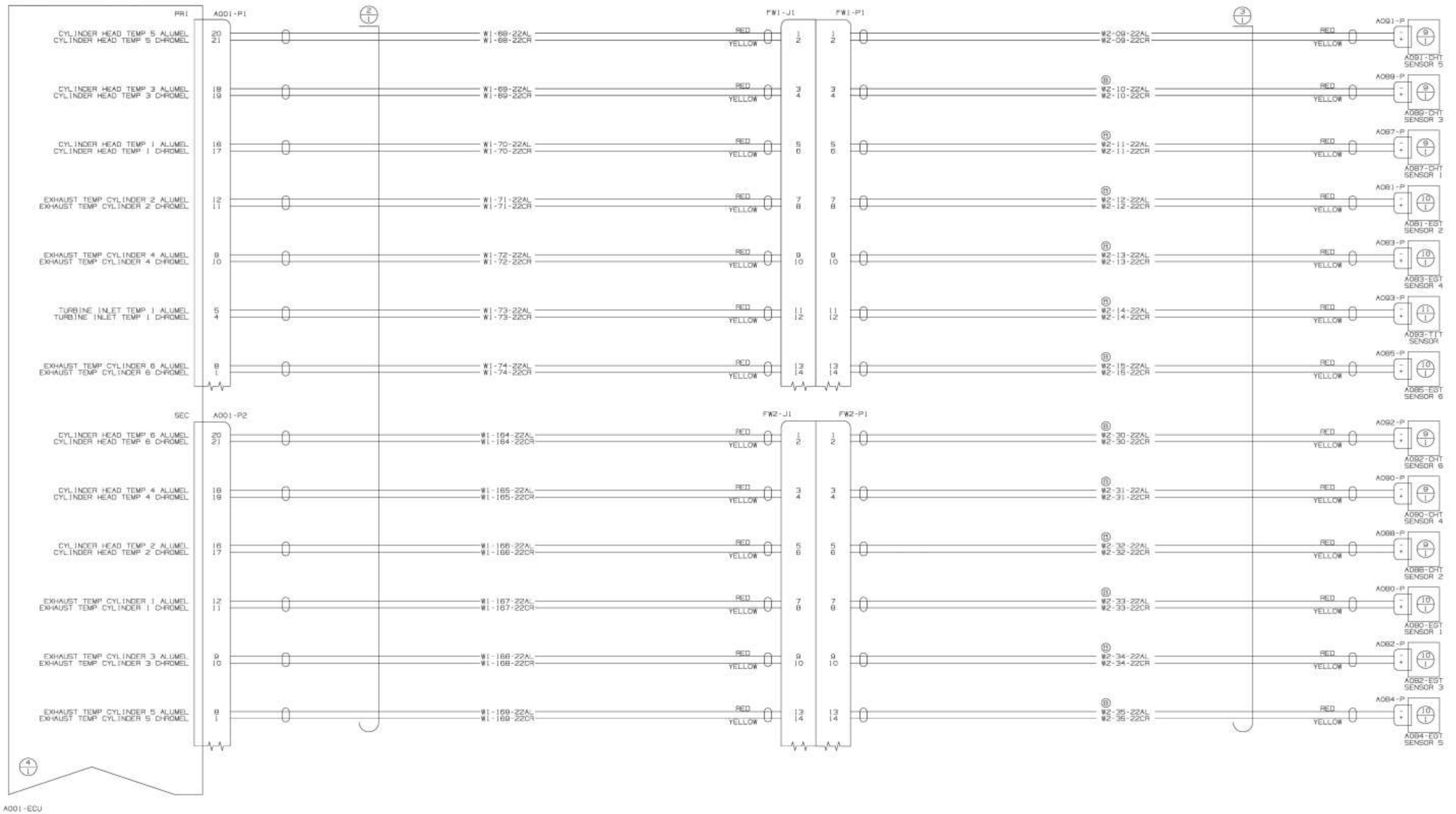


Figure B-5
Schematic T-11327-Y (Sheet 2)

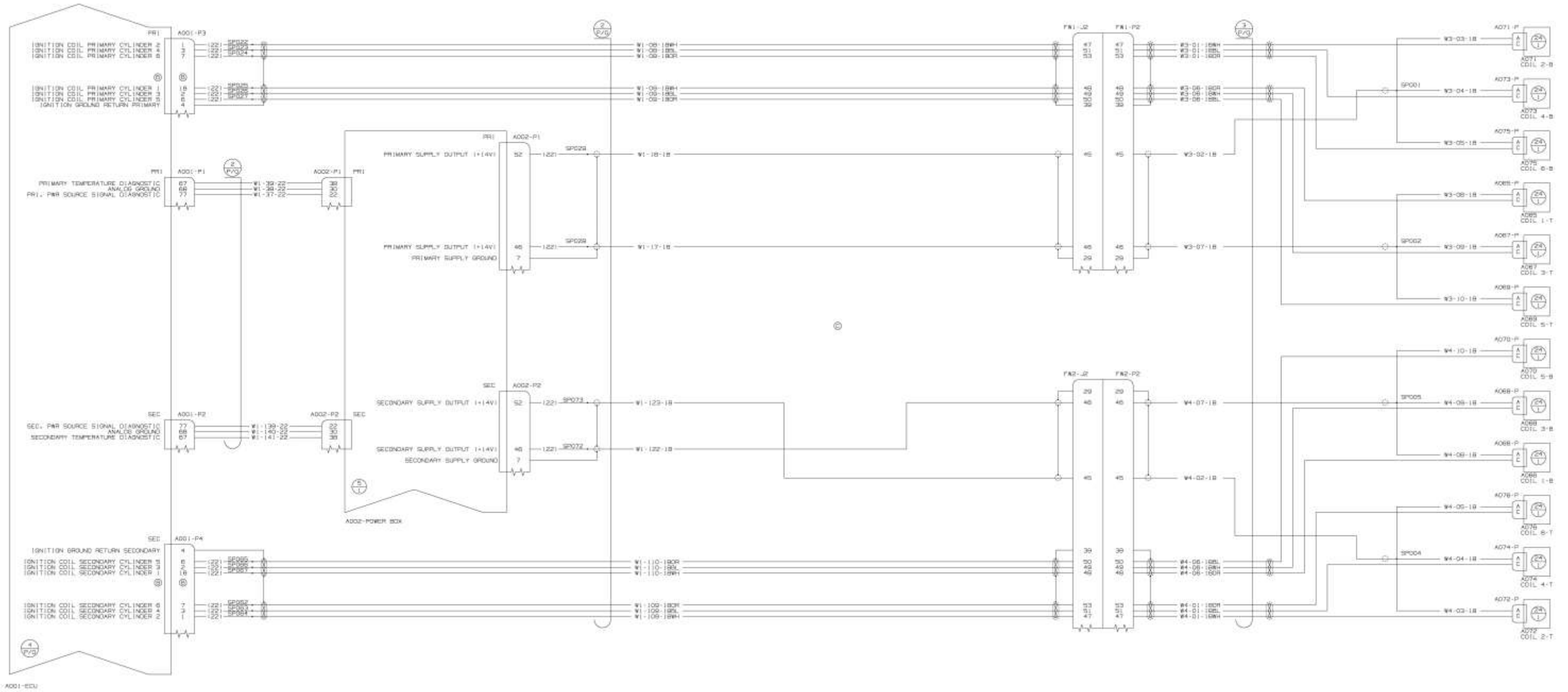


Figure B-6
Schematic T-11327-Y (Sheet 3)

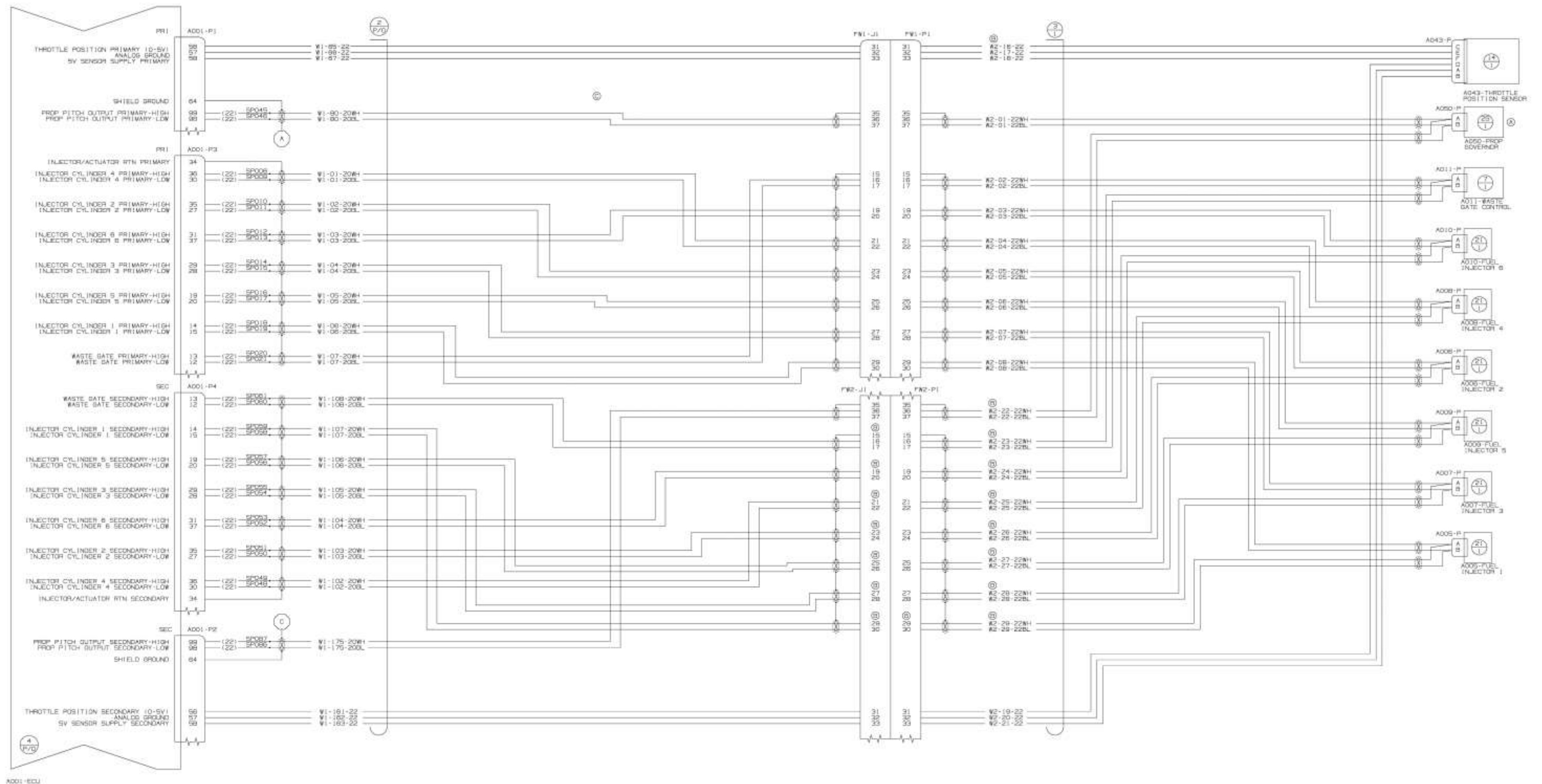


Figure B-7
Schematic T-11327-Y (Sheet 4)

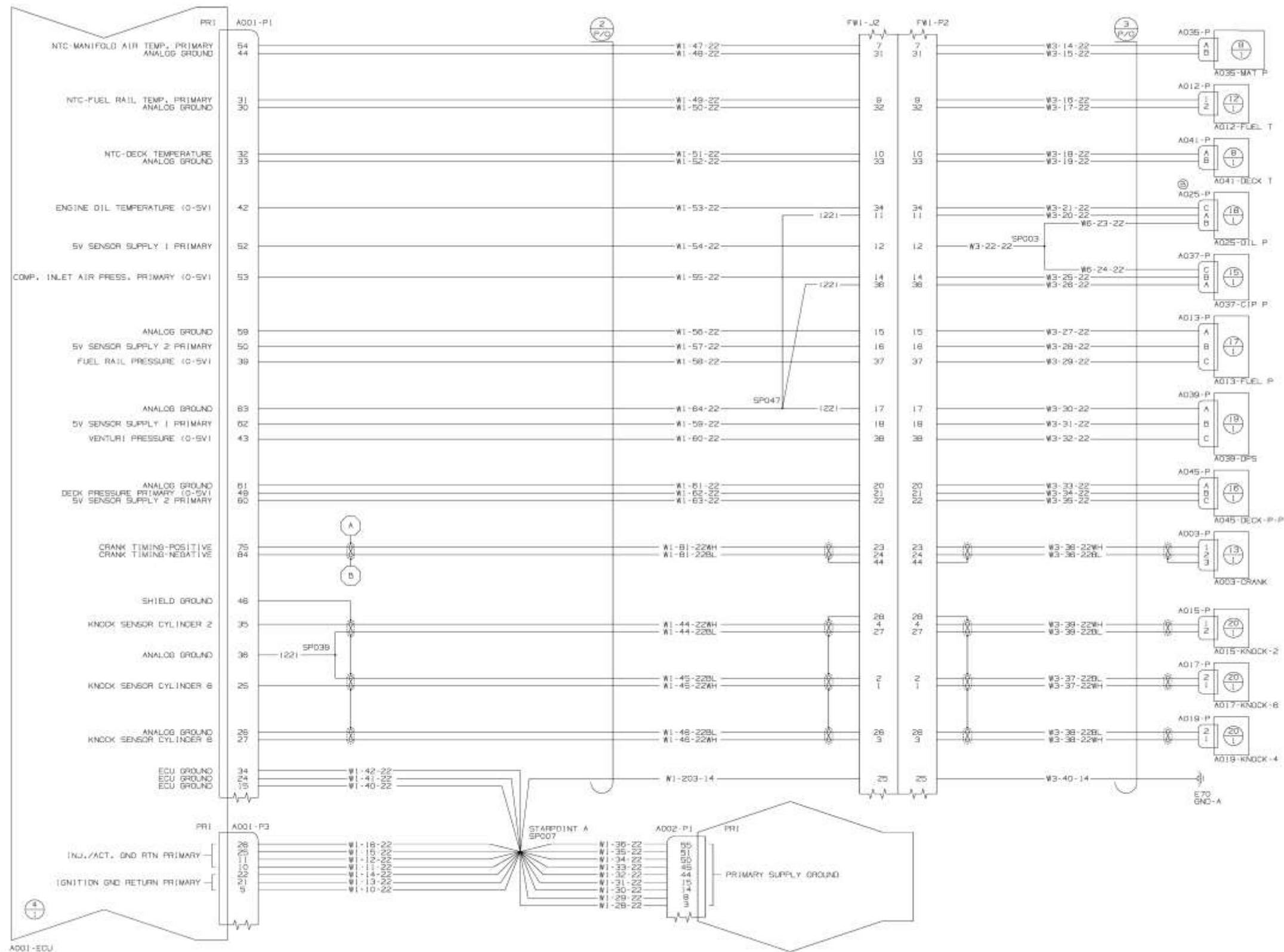


Figure B-8A
Schematic T-11327-Y (Sheet 5)

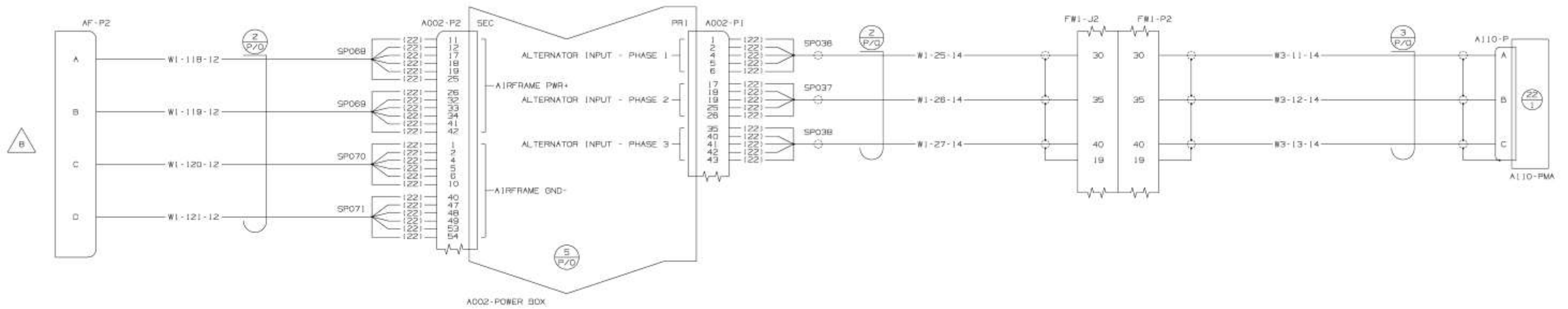


Figure B-8B
Schematic T-11327-Y (Sheet 5)

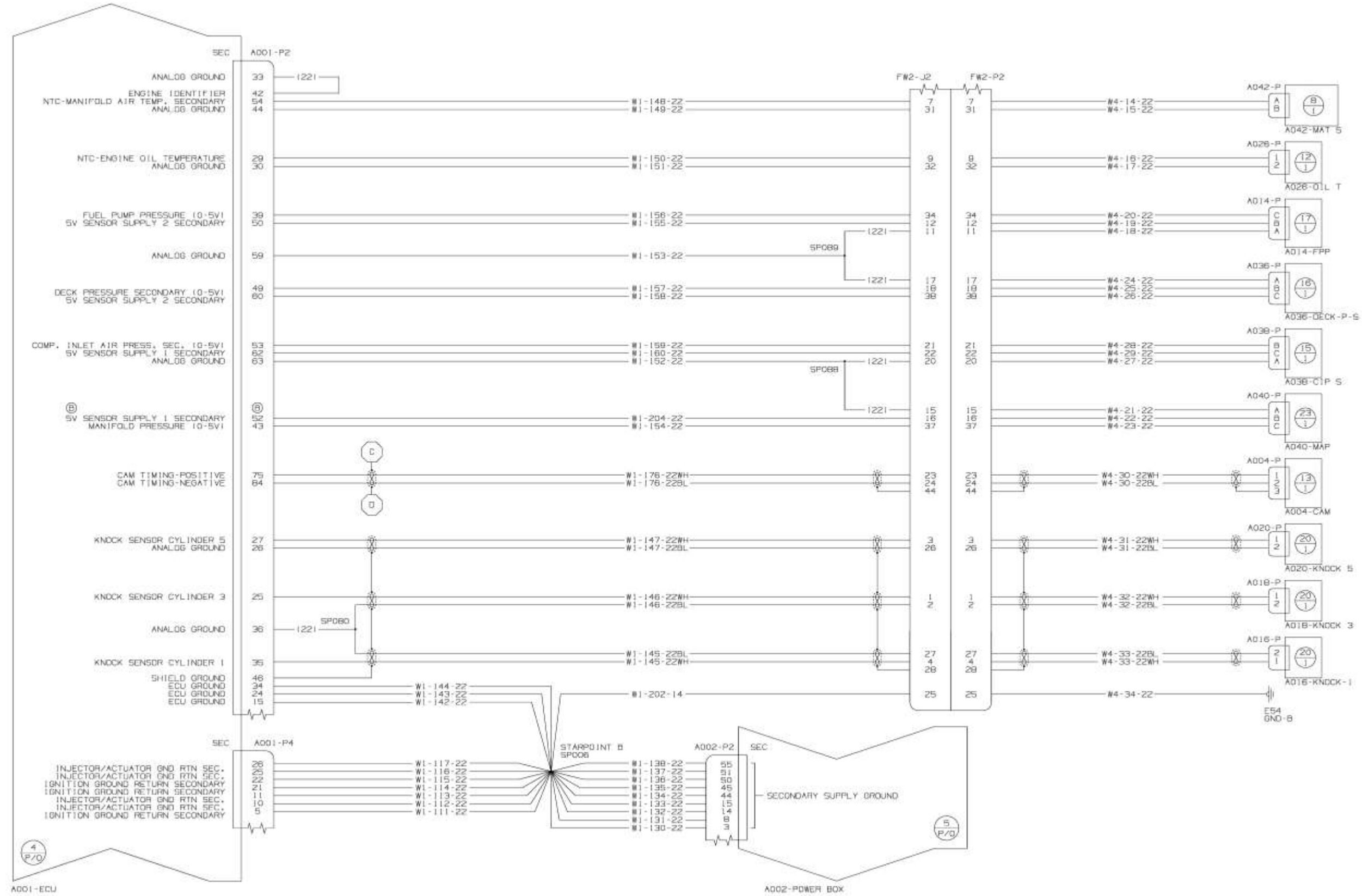


Figure B-9A
Schematic T-11327-Y (Sheet 6)

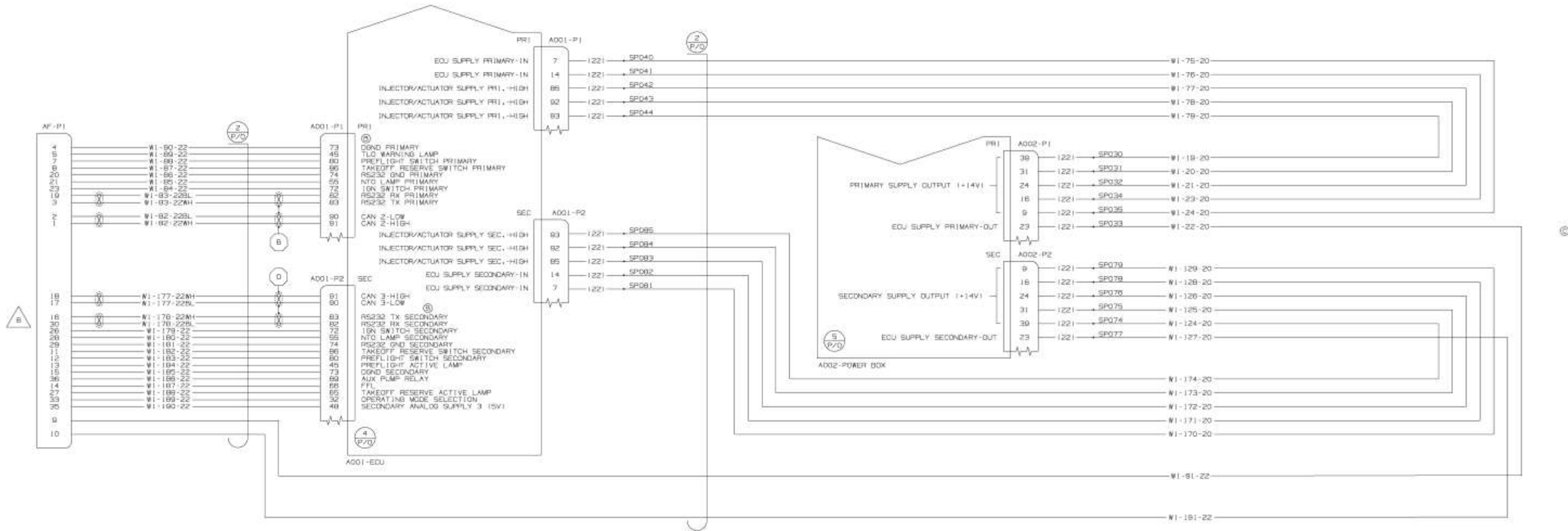


Figure B-9B
Schematic T-11327-Y (Sheet 6)

Communications Bus Data

The CAN and RS232 bus provides data that can be displayed on a third-party display unit compatible with CAN and R232 protocols. Current revisions of CAN and RS232 Specifications can be obtained by contacting Lycoming Engines. These specifications include details, such as units, data format, lists annunciator light colors and functions, and the wiring pin out and schematic from the system. Hardwired annunciator lights are required to display warnings and cautions.

Not all data transmitted on the communications buses are useful to the pilot, but may be used to record or view for maintenance or development. At the discretion of the aircraft manufacturer the following data from directly measured parameters and discrete input system states are considered valid for display to the pilot:

- Engine Oil Temperature (EOT)
- Engine Oil Pressure (EOP)
- Engine Speed (rpm)
- Manifold Pressure (MAP)
- Manifold Air Temperature (MAT)
- Deck Air Pressure (Deck P)
- Deck Air Temperature (Deck T)
- Fuel Rail Pressure (Fuel P)
- Fuel Rail Temperature (Fuel T)
- Fuel Pump Pressure (Fuel PP)
- Fuel Filter Pressure Drop (FFPD)
- Compressor Inlet Pressure (CIP)
- All EGT values (EGT_n)
- All CHT values (CHT_n)
- Turbine Inlet Temperatures (TIT_n)
- Requested Power or Throttle Position (POR)
- Lamp Status
- ECU Supply Volts
- ECU Voltage Source
- Active Fault Count
- TLO Time Remaining
- Trip Time
- Engine Hours (Tach Time)
- Time Before Overhaul hours
- Software and Calibration Cyclic Redundancy Check (CRC)
- All Pre-Flight Test Related Messages
- Operating Mode
- Fault Messages

Data from calculated or indirect control parameters may be useful information during maintenance or development, but do not have sufficient accuracy or usefulness to display to the pilot. Lycoming considers the following parameters as reference only:

- Estimated Percent Power
- Air Mass Flow Rate
- Estimated Fuel Mass Flow Rate
- Estimated Fuel Volume Flow Rate
- All Validity Flags

This page intentionally left blank.

APPENDIX C
FIELD SERVICE TOOL USER MANUAL
ABBREVIATIONS AND ACRONYMS

A	
ADL	Data Logger
AFR	Air-Fuel Ratio
C	
CAN	Controller Area Network
CCP	CAN Configuration Protocol
CHT	Cylinder Head Temperature
CIP	Compressor Inlet Pressure
CRC	Cyclic Redundancy Check
CTC	Cylinder Temperature Control
D	
DC	Direct Current
DLU	Data Logger Unit
E	
ECU	Engine Control Unit (physical box consisting of a primary and a secondary channel)
EECS	Electronic Engine Control System
EGT	Exhaust Gas Temperature
EPA	Environmental Protection Agency
ETC	Electronic Throttle Control
F	
FAA	Federal Aviation Administration
FAR	Federal Aviation Regulations
FAR	Fuel Air Ratio
FFL	Fault Found Lamp
FHA	Functional Hazard Assessment
FRT	Fuel Rail Temperature
FSM	Finite State Machine
FST	Field Service Tool
K	
KAM	Keep Alive Memory

**FIELD SERVICE TOOL USER MANUAL
ABBREVIATIONS AND ACRONYMS (CONT.)**

M	
MAT	Manifold Air Temperature
N	
NTC	Negative Temperature Coefficient type Thermistor
NTO	No Take Off
P	
PFT	Pre-Flight Test
PSSA	Preliminary System Safety Assessment
R	
RAM	Random Access Memory
ROC	Rate of Change
ROM	Read Only Memory
RTCA	Radio Technical Commission for Aeronautics
RTD	Resistance Temperature Detector
S	
SAE	Society of Automotive Engineers
SPF	Single Point Failure
T	
TBD	To Be Decided
TBO	Time Between Overhaul
TLO	Time Limited Operation
TIT	Turbine Inlet Temperature
TPS	Throttle Position Sensor
W	
WGA	Wastegate Actuator

SYSTEM REQUIREMENTS

The following hardware is necessary to use the Field Service Tool (FST):

- A laptop using Windows 7, 8.1, or 10 operating system with an internet connection.
- iE2 Service Cable - ST-528 (Figure C-1).
- iE2 Field Service Tool CAN Interface - ST-530 (Figure C-2).

NOTICE: ST-528 and ST-530 are available from an Authorized Lycoming Engines Distributor.



Figure C-1
iE2 Service Cable - ST-528



Figure C-2
iE2 Field Service Tool CAN Interface - ST-530

This page intentionally left blank.

SOFTWARE INSTALLATION

This chapter contains step-by-step instructions for installing the FST software.

1. With the laptop turned on and connected to the internet, navigate to the Lycoming Engines Home Page www.lycoming.com.
2. Click on the iE2 Portal tab in the ribbon at the top of the page (Figure C-3).

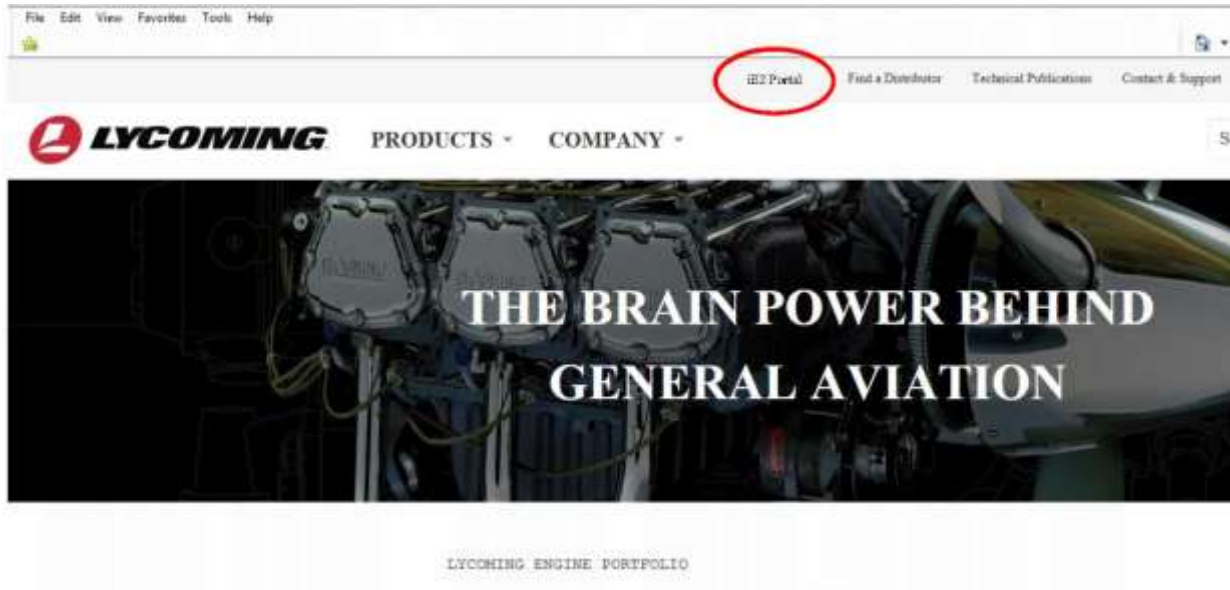


Figure C-3
iE2 Portal on the Lycoming.com Website

3. If you are not already registered, click on **REGISTER** (Figure C-4) and enter your email address and name (Figure C-5) on the First-Time Registration Page.



Figure C-4
Lycoming iE2 Software Portal


 A screenshot of the Lycoming iE2 Software Download registration form. The page header includes the Lycoming logo and 'Lycoming iE2 Software Download'. The form contains the following fields: 'Email*' (with an asterisk indicating it is required), 'First Name*' (with an asterisk and 'Required' text), 'Last Name*' (with an asterisk), and 'Company'. At the bottom of the form is a 'Continue' button.

Figure C-5
First-Time Registration Page

4. Click **Continue** on the First-Time Registration Page and you will be transferred to the Password Entry Page to create and confirm a password (Figure C-6).
5. After you have successfully registered, you will receive a confirmation email from Lycoming.

Figure C-6
Password Entry Page

6. If you are already registered, click on **LOGIN** (Figure C-7) and go directly to the Log-In page (Figure C-8) to enter your username and password.



Lycoming's iE2 Portal

REGISTER

Register for Lycoming's iE2 Software Portal here.

Once you register, you can download the iE2 Software.

LOGIN

Login to your existing Lycoming iE2 Software Portal account here.

Login to the iE2 portal to download the latest version of the iE2 Software.

SHARE DATA

Share iE2 engine data with Lycoming's Product Support team here.

Figure C-7
Lycoming iE2 Software Portal

Figure C-8
Log-In Page

7. After log-in, navigate to the **Shared Folders** page (Figure C-9) and double-click on the **iE2 Software Download**.

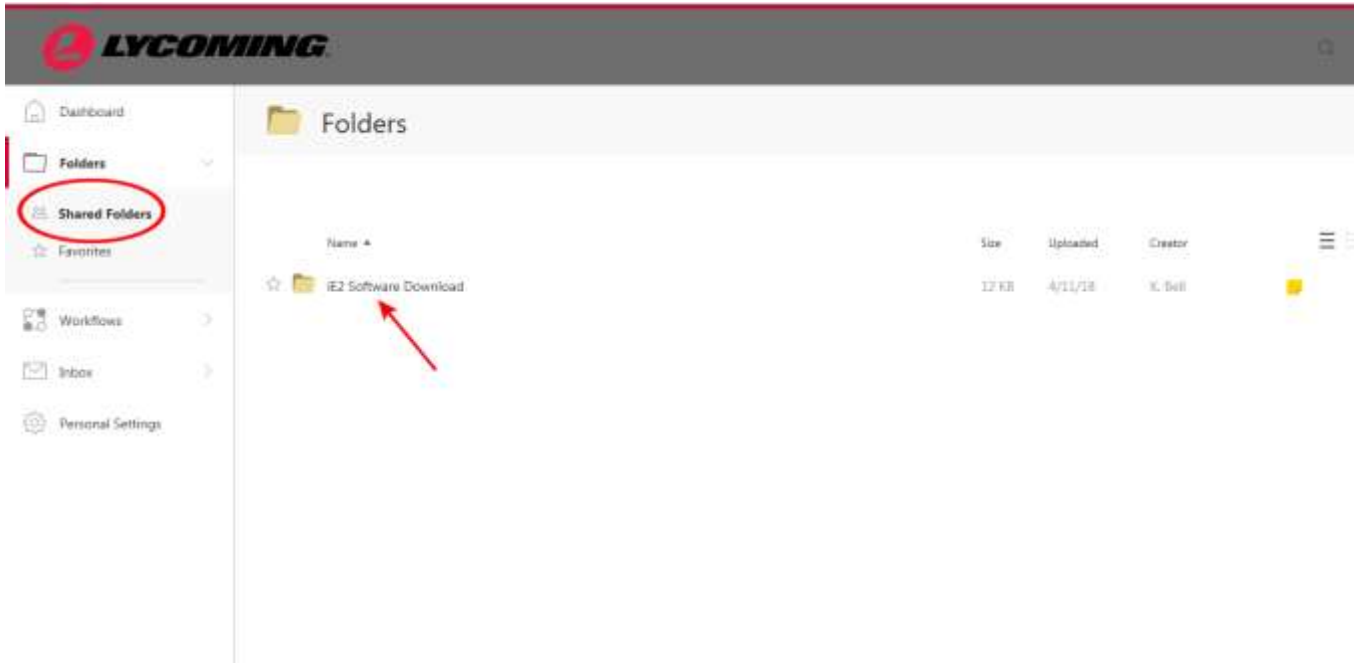


Figure C-9
Shared Folders Page

8. You will be transferred to the **iE2 Software Download** page (Figure C-10). Double-click on the **iE2 Software** icon.

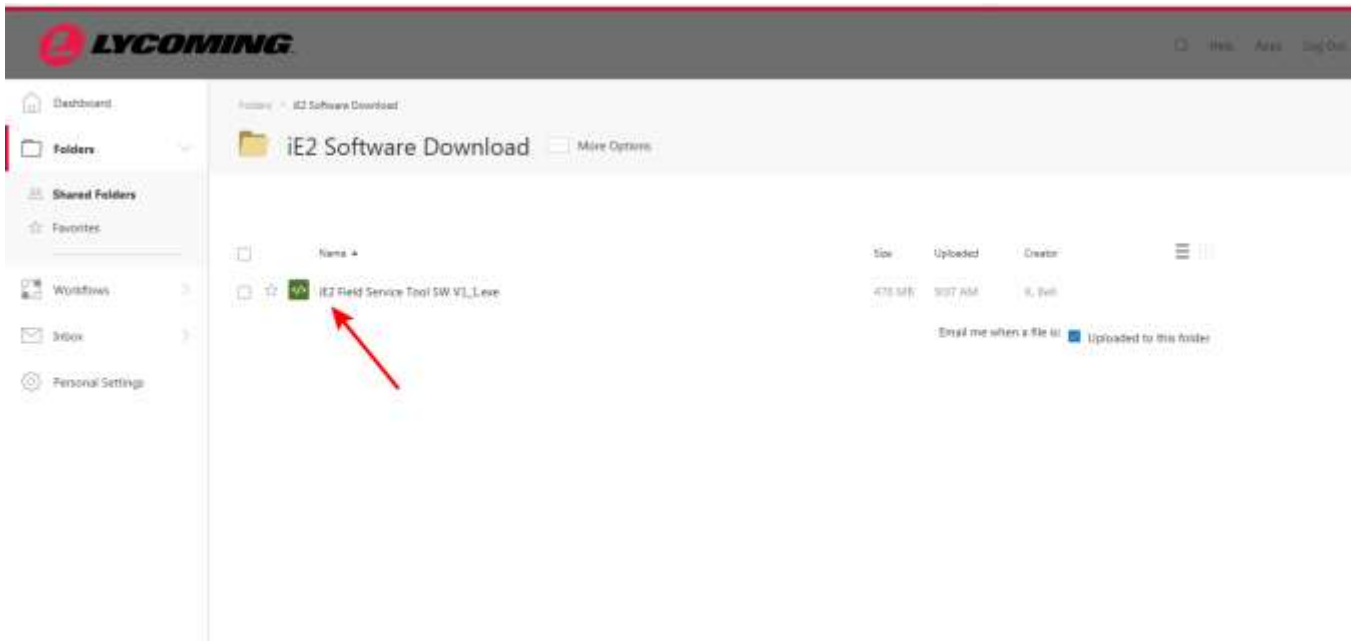


Figure C-10
iE2 Software Download Page

9. Check the box to the left of the “iE2 Field Service Tool SW” icon then click on the **Download** button (Figure C-11).

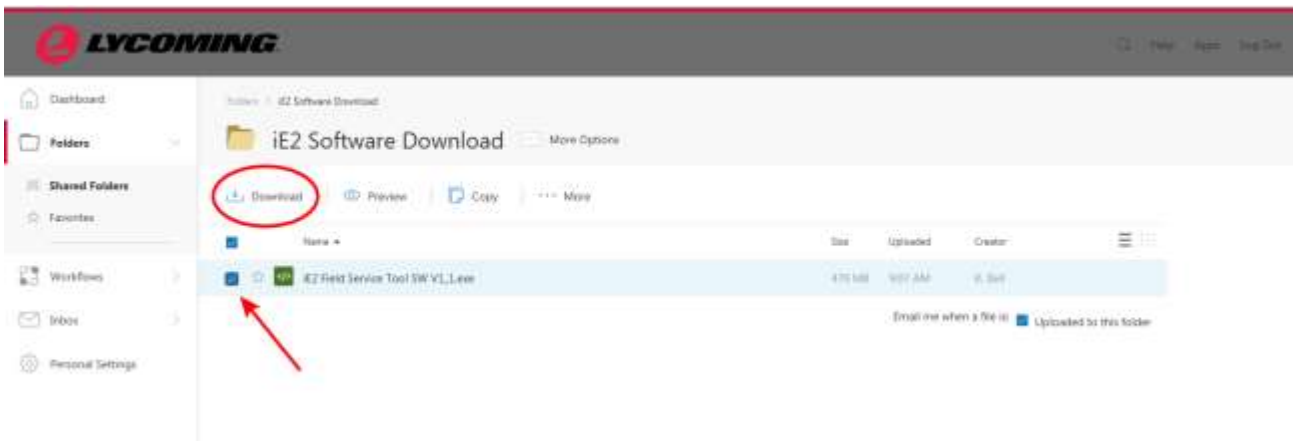


Figure C-11
File Download Page

10. Click **Save As** from the pop-up window at the bottom of the page (Figure C-12) and choose a file folder location for the download from the Save As dialog window, then click **Save**.

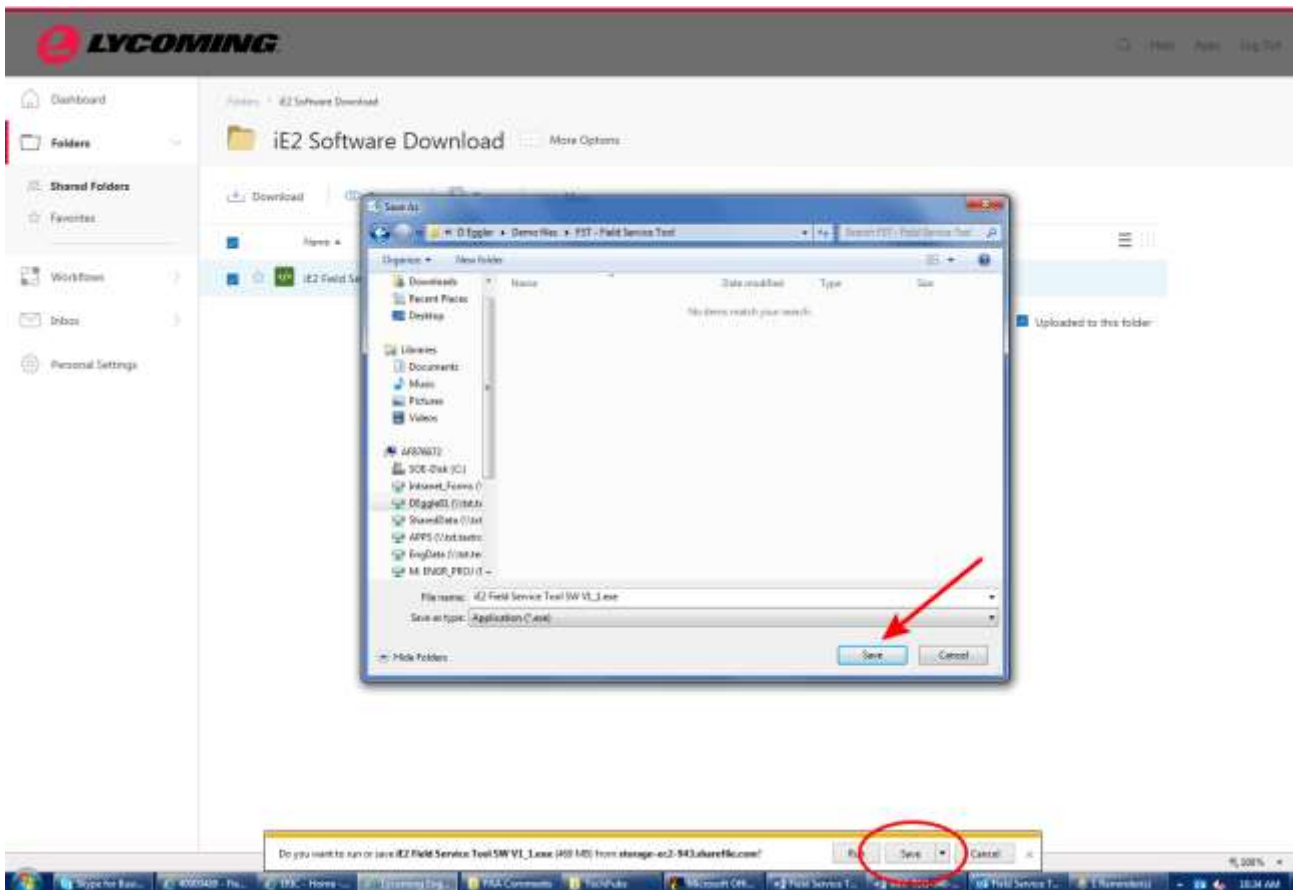


Figure C-12
File Save Page

11. From the file folder where the download was saved, double-click the “iE2 Field Service Tool SW” icon (Figure C-13) to open the Destination Directory.

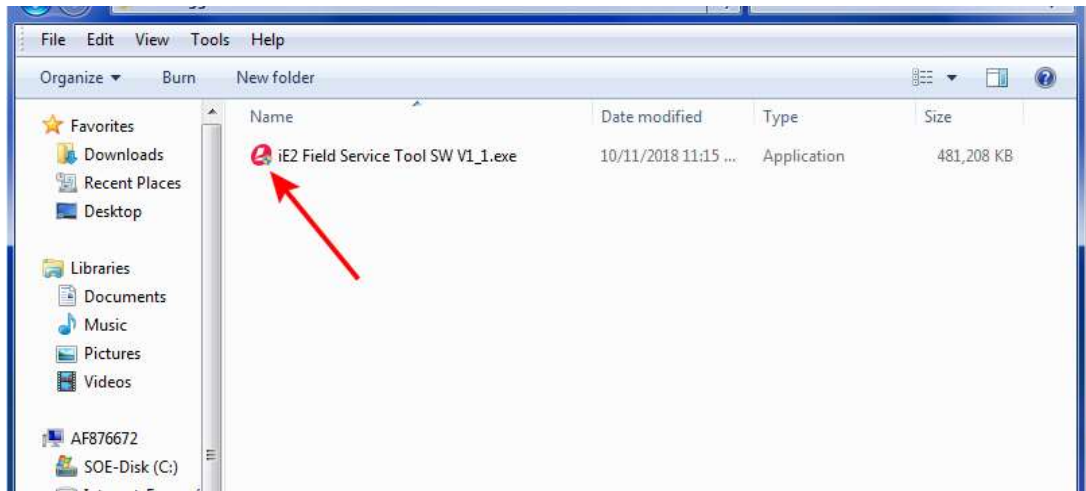


Figure C-13
Saved File Folder

12. Click the **Setup** button on the WinZip Self Extractor dialog box (Figure C-14).

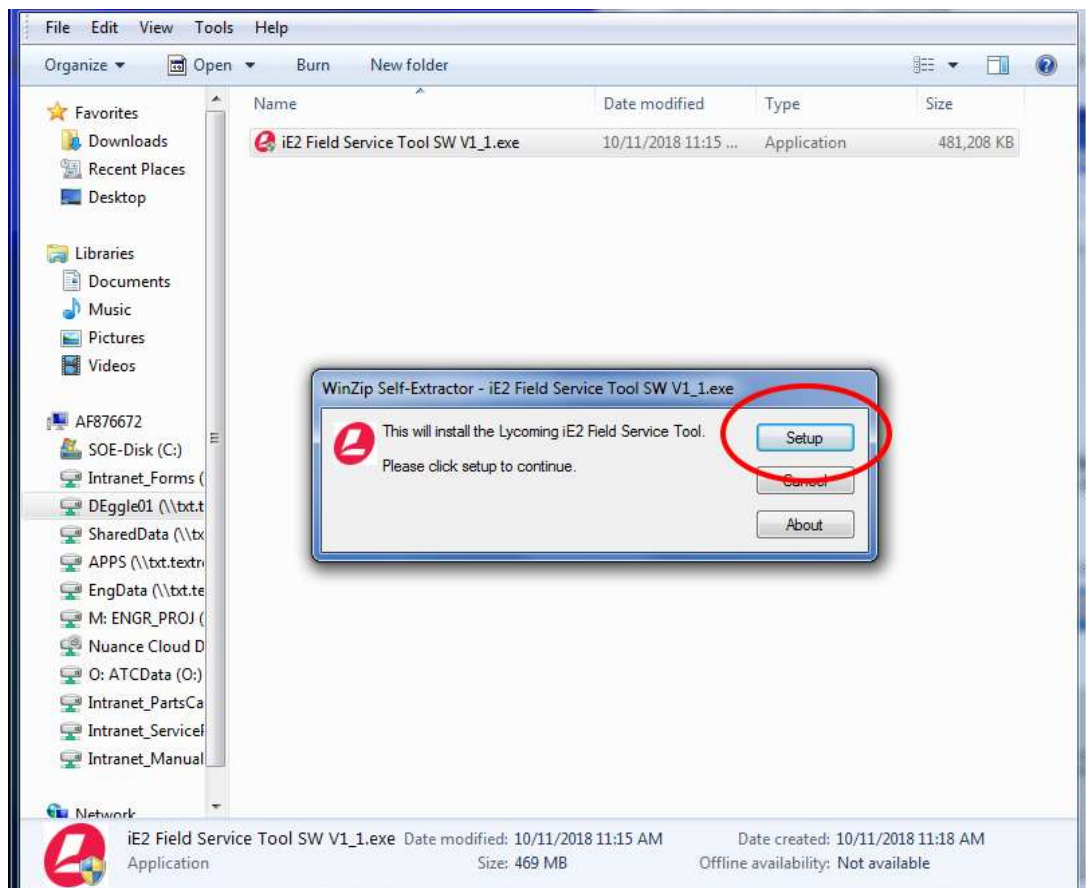


Figure C-14
WinZip Self Extractor Dialog Box

- Choose the folder location for the software in the Destination Directory (Figure C-15), then click the **Next** button.

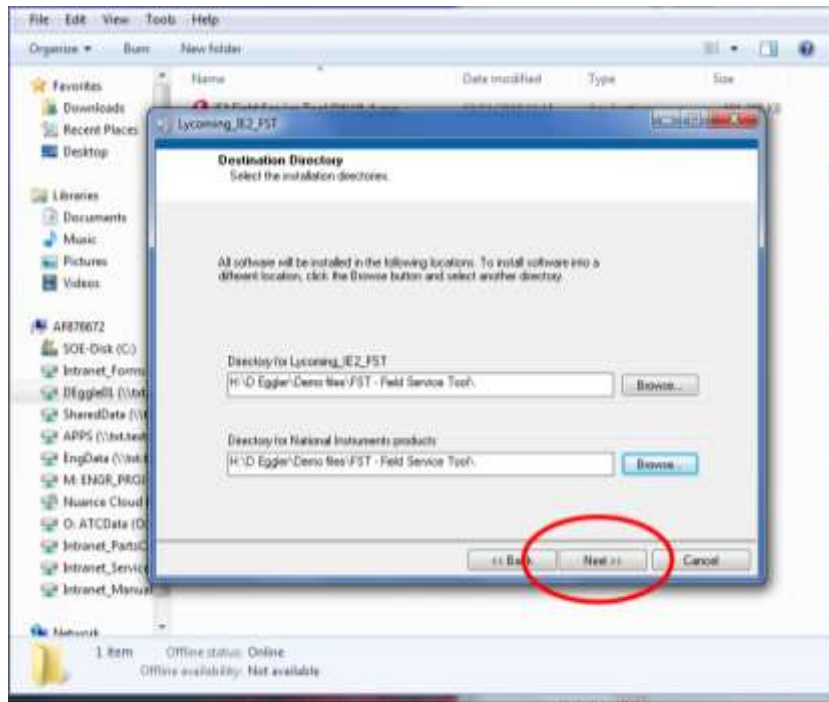


Figure C-15
Destination Directory Dialog Box

- Read the Lycoming Software License Agreement then choose the “I accept the License Agreement” button. Click **Next** on the License Agreement page (Figure C-16).
- Read the National Instruments Software License Agreement then choose the “I accept the License Agreement” button. Click **Next** on the License Agreement page (Figure C-17).

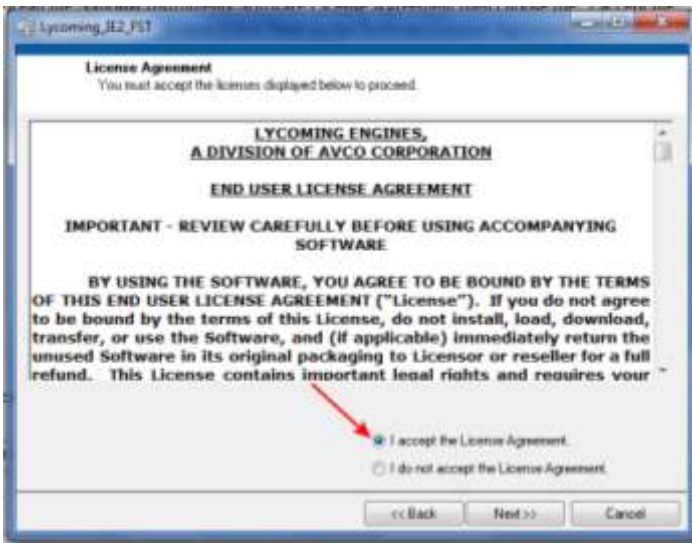


Figure C-16
Lycoming Software License Agreement



Figure C-17
Software License Agreement

NOTICE: The program will create an icon in the Program Menu named “FST” and a folder on the laptop hard drive (Figure C-18) which contains:

- Field Service Tool program
- A separate folder for each engine/ECU serial number for storing downloaded Active Fault Codes (each time a new engine/ECU serial number is entered)
- A separate folder for each engine/ECU serial number for storing Service History Faults (each time a new engine/ECU serial number is entered)
- A separate folder for each engine/ECU serial number for storing TBO Fault History (each time a new engine/ECU serial number is entered)
- A separate folder for each engine/ECU serial number for storing data from the Data Logger (each time a new engine/ECU serial number is entered)

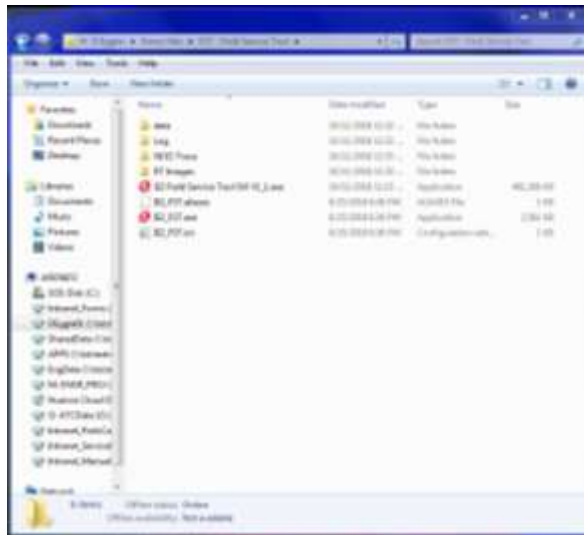


Figure C-18
Folder on the Laptop Hard Drive

16. After the “Installation Complete” message is shown, click the **Finish** button (Figure C-19).

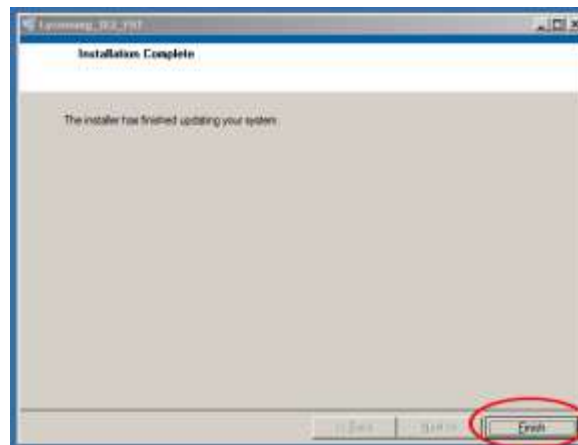


Figure C-19
Installation Complete

17. Reboot the laptop to finalize the FST installation.

This page intentionally left blank.

ECU TO FST CONNECTION

Connect the ECU to the laptop where the FST is installed

1. Connect the USB plug end of the iE2 Field Service Tool CAN Interface (ST-530) to the USB port on the laptop.
2. Connect the CAN Interface plug end of the iE2 Service Cable (ST-528) to the CAN Interface.
3. Connect the RCA plug end of the iE2 Service Cable (ST-528) to the airframe-supplied RCA jack in the cockpit.

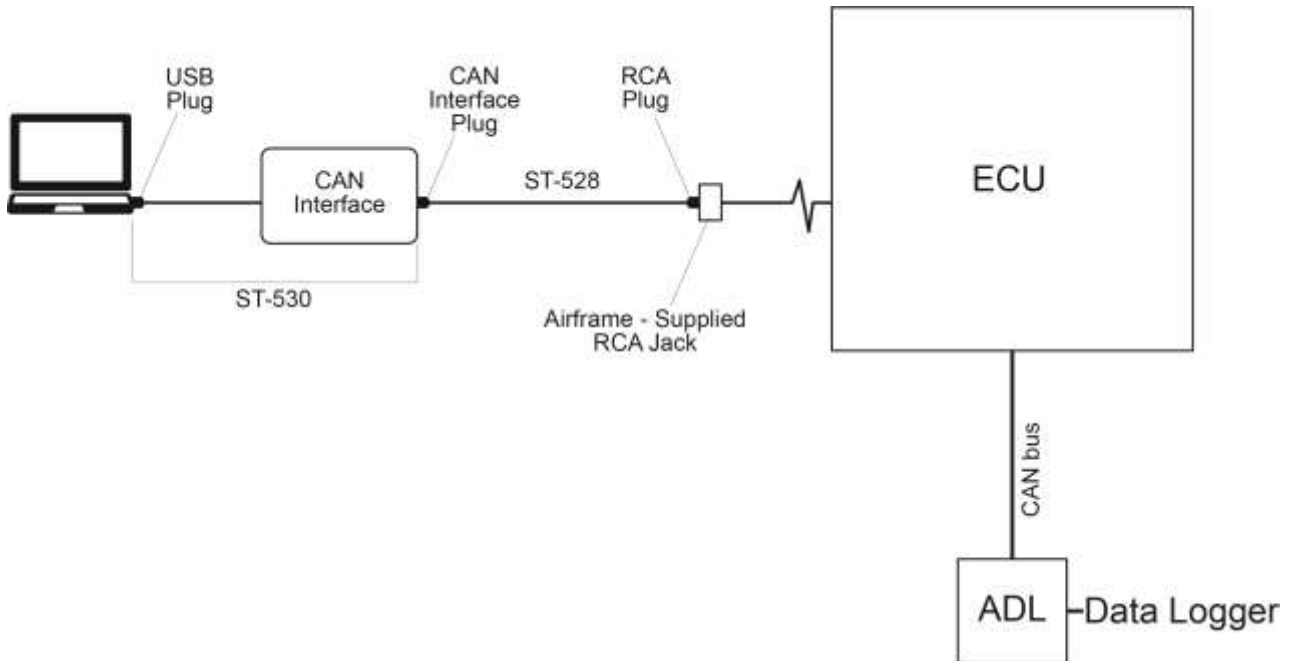


Figure C-20
Laptop Connected to the ECU

This page intentionally left blank.

ACCESS THE FIELD SERVICE TOOL

This chapter contains step-by-step instructions for accessing the FST installed on the laptop.

Start the FST Program

NOTICE: Always connect the laptop to the RCA jack in the cockpit before opening the FST program.

1. Connect the laptop to the RCA jack in the cockpit per the “ECU to FST Connection” chapter.

NOTICE: If possible, use ground power instead of the aircraft batteries to supply power to the aircraft.

2. Turn power to the ECU **ON** per instructions in the applicable aircraft manual.
3. Turn on the laptop.
4. Click the **Start** button.
5. Click **All Programs**.
6. Find the FST Folder in the menu and double-click on **Field Service Tool** (Figure C-21).

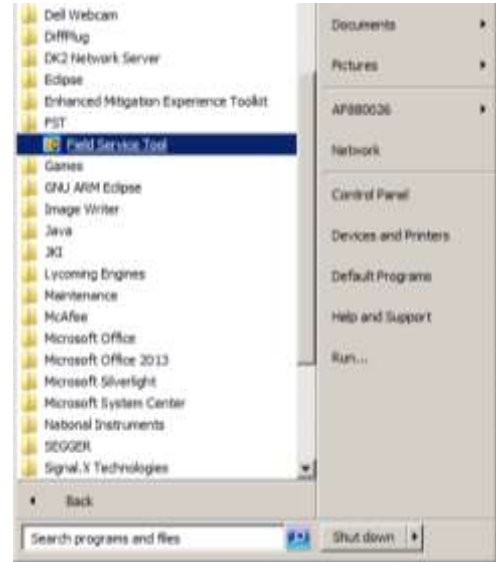


Figure C-21
Field Service Tool Folder

NOTICE: The program will open and display the Home screen (Figure C-22). If the program does not open, refer to the “Field Service Tool - Software Problems” chapter in this manual.

NOTICE: Each Tab is an independent function and do not have to be accessed in a certain order.

Home Tab

1. Click the **Upload** button on the Home screen (Figure C-22) to display:
 - Engine Serial Number
 - Engine Hours
 - ECU Serial Number
 - ECU Hours
 - CRC Code Version
 - CRC Data Version
 - CRC Boot Version
2. Verify that the serial numbers displayed by the FST are the same as the serial numbers on the data tags on the engine and the ECU.



Figure C-22
Home Tab

NOTICE: Connection status is indicated in the lower left corner of the screen.

3. If the “ECU Connection Status” indicator in the lower left corner of the screen reads “Not Connected” (Figure C-23):
 - A. Examine the cable and connection between the CAN Adapter and the ECU to make sure the connections are secure, and the cable is not damaged.
 - B. Replace damaged cables or cables with damaged connectors.
 - C. Attach the cable per the “ECU to FST Connection” Chapter in this manual.
 - D. Close the FST program per the Close the FST Program” section in this chapter then start to FST program per the “Start the FST Program” previously in this chapter.

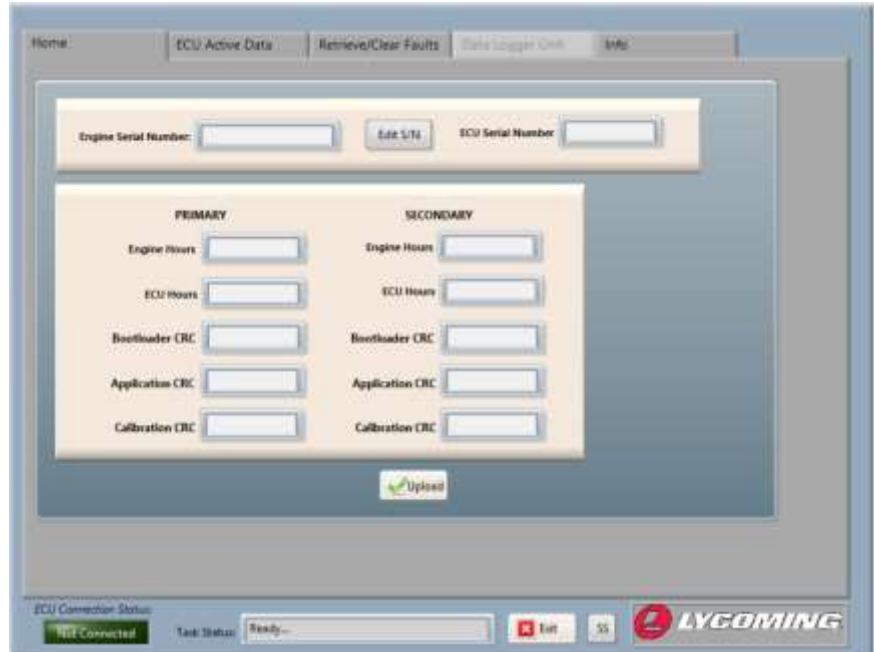


Figure C-23
ECU Not Connected

4. If the engine serial number displayed by the FST is not the same as the serial number on the engine data tag:
 - A. Click the **Edit S/N** (Figure C-24) button on the “Engine Serial Number” panel.
 - B. Enter the correct engine serial number in the “New Serial Number” box of the “Prompt User for Input” window.
 - C. Click **OK** then click **Upload** on the “Engine Serial Number” panel.

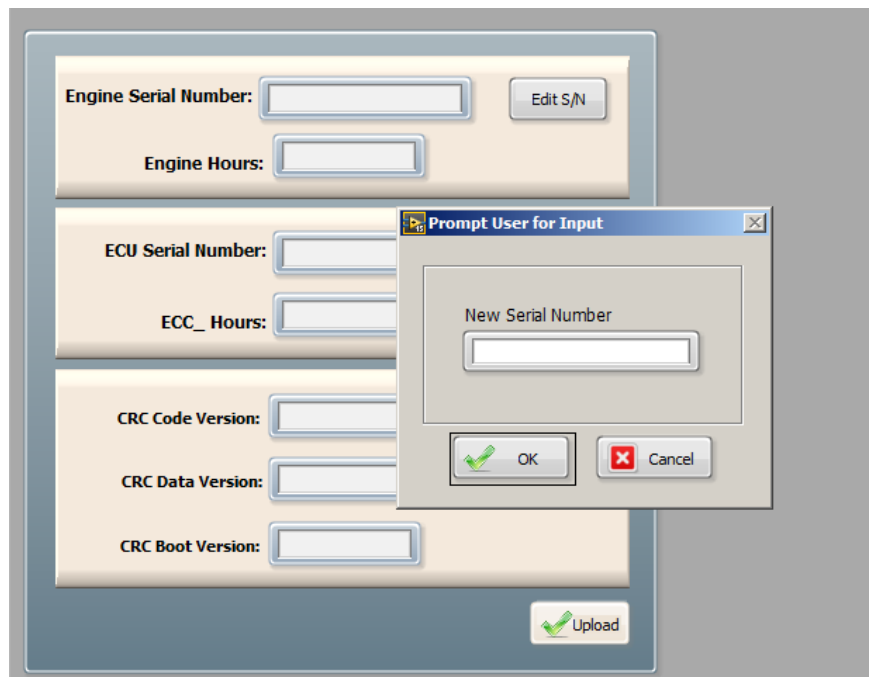


Figure C-24
New Serial Number Window

Displaying ECU Active Data

The “ECU Active Data” screen contains two panels.

- The “Active Data” panel displays current active data.
 - The “Active Faults” panel displays active faults as they are broadcast from the ECU.
1. Open the FST program per the “Start the FST Program” procedure.
 2. Click on the ECU Active Data tab (Figure C-25).
 3. Click the **Start** button on the “ECU Active Data” screen (Figure C-25) to display active faults data from the ECU.



Figure C-25
ECU Broadcast Faults Tab

NOTICE: If the “Active Faults” panel is blank there is no active fault data in the ECU.

4. Click the **Stop** button (Figure C-26) to stop reading active data from the ECU.

NOTICE: Must be streaming active data to record.

5. Click the **Start Recording** button (Figure C-26) to record the broadcast active data in a file on the laptop.

NOTICE: After clicking on the **Start Recording** button it will change to a **Stop Recording** button. Click on the **Stop Recording** button to quit recording the broadcast active data in a file on the laptop.



Figure C-26
Start and Stop Recording Buttons

3. From the “Retrieve ECU Faults” drop-down menu (Figure C-29) select one of the following options:
 - Upload TBO Fault History
 - Upload Service History Faults
4. Click the **OK** Button on the “Retrieve ECU Faults” drop-down menu to start to retrieve the selected data from the ECU.
5. The Data Table will show streaming data from the ECU.

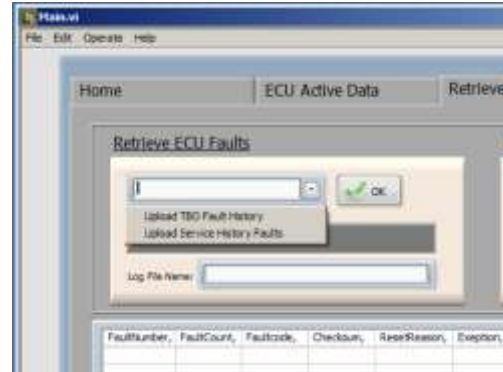


Figure C-29
Retrieve DLU Data

Clearing a Fault

1. From the “Clear ECU Faults” drop-down menu (Figure C-30) select one of the following options:
 - Clear TLO
 - Clear Service History Faults
2. Click the **OK** Button on the “Clear ECU Faults” drop-down menu to clear the selected faults from the ECU.

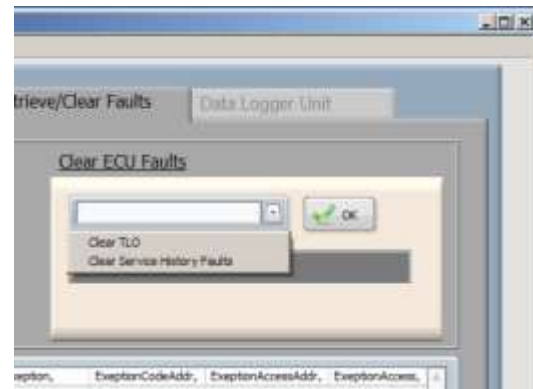


Figure C-30
Clear ECU Faults

NOTICE: The data from the Data logger unit will be logged in a folder in the FST folder on the laptop hard drive.

Retrieving Data Logger Unit Information

1. Open the FST program per the “Start the FST Program” procedure.
2. Click on the “Data Logger Unit” tab (Figure C-31).

NOTICE: The destination file for saved data is identified as the “Log File Name” on the “Info Tab” (Figure C-28).

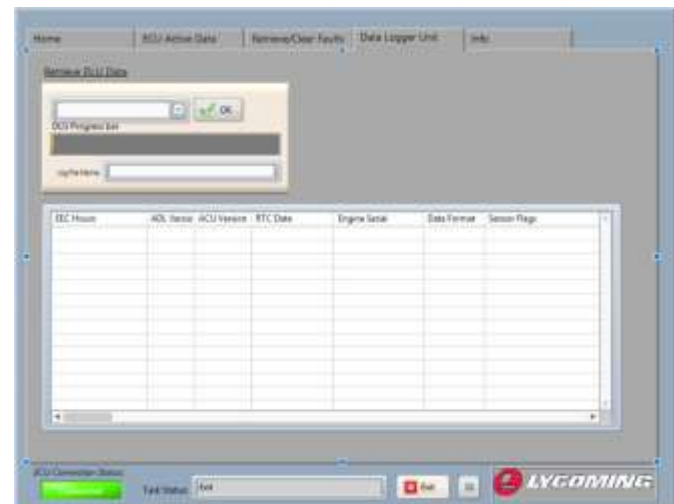


Figure C-31
Data Logger Unit Tab

NOTICE: If the data logger is not installed or not communicating with the ECU a “Data Logger Unit was not detected” warning will be displayed (Figure C-32). Check the connection between the data logger and the ECU and correct the problem. If the problem persists, contact Lycoming.

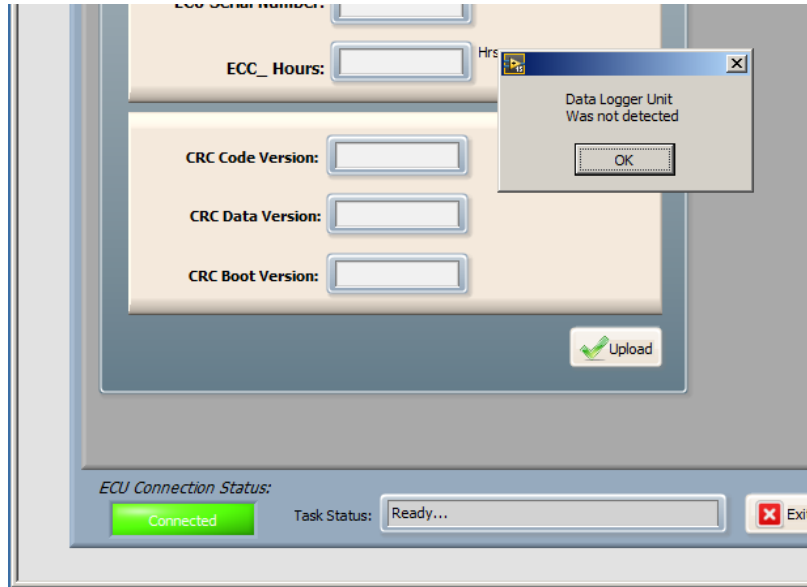


Figure C-32
Data Logger Unit Not Detected

3. From the “Retrieve DLU Data” drop-down menu (Figure C-33) select the following option:
 - Run Time Data
 - Trip Time Data
 - Life Time Data
4. Click the **OK** button to start to retrieve the selected data. The Data Table will show streaming data from the ECU.

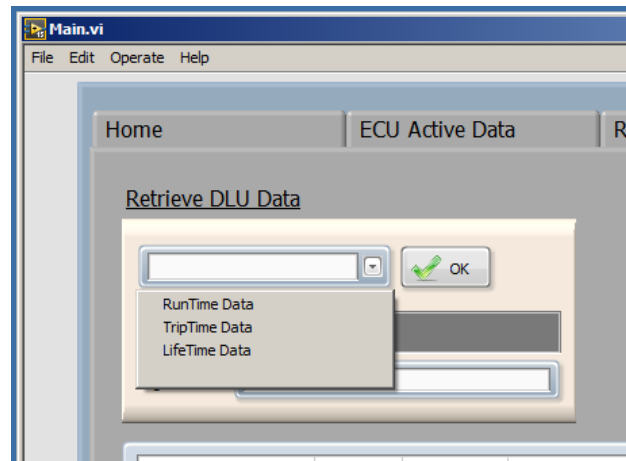


Figure C-33
Retrieve DLU Data Drop-Down Menu

NOTICE: The ECU data will be logged in a file using the following format:

- Decode • Data • Year • Month • Day • Hour • Minute • Second • AM/PM

Close the FST Program

NOTICE: Do not close the program by clicking on the X in the upper right of the screen.

1. Close the FST program by clicking on the **Exit** button at the bottom of the screen (Figure C-34).

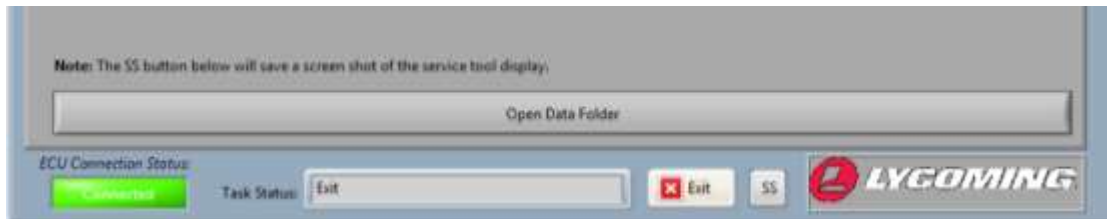


Figure C-34
Exit Button

Disconnect the ECU and FST

1. Turn power to the ECU **OFF** per instructions in the applicable aircraft manual.
2. Disconnect the CAN adapter from the airframe-supplied RCA jack in the cockpit.
3. Disconnect the NI-8473 CAN adapter (Figure C-20) from the USB port on the laptop.

This page intentionally left blank.

SENDING DATA TO LYCOMING TECHNICAL SUPPORT

Sending Data

Lycoming Engines has set up a file share site so that data files from the FST can be analyzed by the Technical Support Department at Lycoming. To upload data files to the file share site:

1. With the laptop turned on and connected to the internet, navigate to the Lycoming Engines Home Page www.lycoming.com.
2. Open Lycoming's iE2 Portal (Figure C-35) and click on **SHARE DATA**.

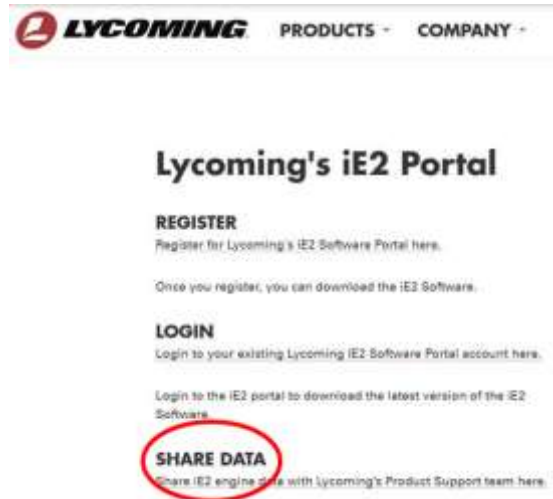


Figure C-35
Lycoming iE2 Software Portal

3. Enter your email, name, and company in the designated areas on the left-hand side of the page (Figure C-36).
4. Click on the icon for all the data files you want to share with Lycoming Technical Support, then drag-and-drop the files in the designated area on the right-hand side of the page.
5. After all data files have been dropped in the designated area, click the **UPLOAD** button.

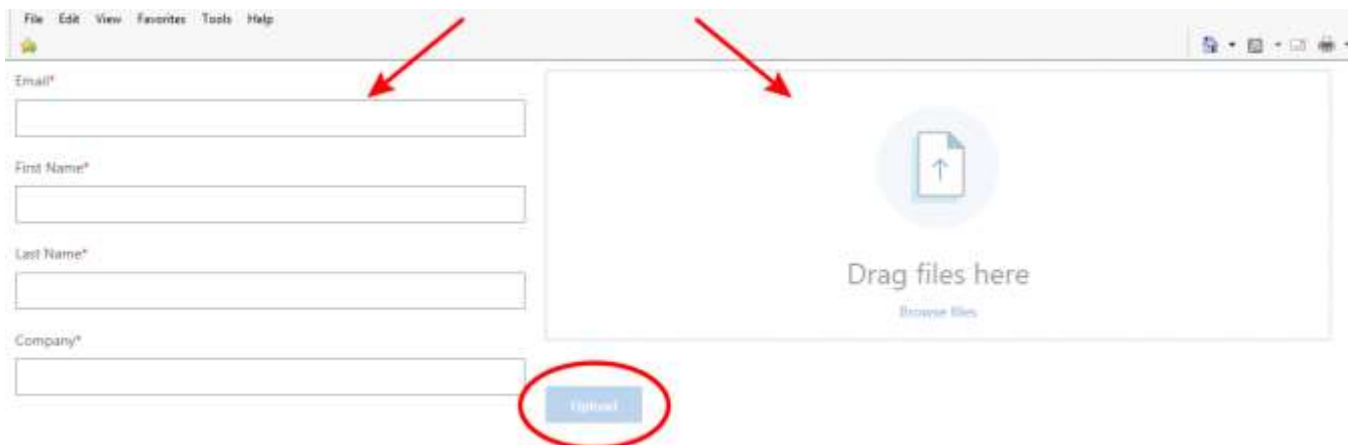


Figure C-36
Lycoming Engines iE2 File Share Page

This page intentionally left blank.

FIELD SERVICE TOOL - SOFTWARE PROBLEMS

Table 1 shows the more common and recurring problems, causes, and corrective actions. Continue from the simplest to the most complex possible causes.

Table C-1
Corrective Action Guide

Problem	Cause	Corrective Action
Software will not load on the laptop.	Laptop operating system is not compatible with Field Service Tool software.	Make sure the laptop has Windows 7, 8, 8.1, or 10 operating system installed. Replace the laptop if necessary.
Laptop will not interface with the ECU.	Aircraft power is off.	Turn the aircraft power on.
	Cable is not connected.	Check all cable connections; make sure all plugs are correctly installed.
	Cable is damaged or broken.	Contact Lycoming for a replacement iE ² Service Cable (ST-528).
	CAN Adapter is not operating correctly.	Contact Lycoming for a replacement iE ² Field Service Tool CAN Interface (ST-530).
After opening the FST program, the “ECU Connection Status” indicator in the lower left corner of the screen reads “Not Connected”.	There is no communication between the laptop and the ECU.	Examine the cable and connection between the CAN Adapter and the ECU. <ol style="list-style-type: none"> 1. Make sure the connections are secure. 2. Replace a damaged cable.

This page intentionally left blank.

APPENDIX D
TROUBLESHOOTING GUIDE

The Troubleshooting Guide recommends corrective action for the fault codes to remove the root cause which will ultimately enable the fault code to be cleared. In some instances, multiple related fault codes can display if they have a common or associated root cause. In these cases, a logic fault tree is given to help isolate the root cause.

⚠ WARNING ENGINE MOTORING AND OPERATION IS REQUIRED DURING TROUBLESHOOTING. KEEP CLEAR OF THE ROTATIONAL RADIUS OF THE PROPELLER TO PREVENT PERSONNEL INJURY OR DEATH.

⚠ CAUTION DO NOT REMOVE POWER FROM THE ENGINE WHILE DOWNLOADING SERVICE OR TBO HISTORY, OR CLEARING SERVICE FAULTS. DAMAGE TO THE ECU MEMORY CAN OCCUR.

NOTICE: If a satisfactory outcome is not achieved using this troubleshooting guide, contact Lycoming Engines product support.

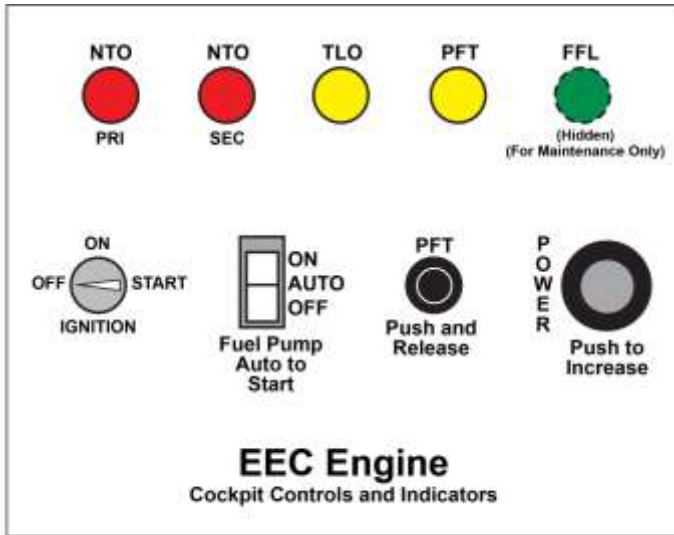
TROUBLESHOOTING GUIDE ABBREVIATIONS AND ACRONYMS

A	
ACJ	Auto Cold Junction
C	
CAN	Controller Area Network
CCP	CAN Configuration Protocol
CHT	Cylinder Head Temperature
CIP	Compressor Inlet Pressure
CRC	Cyclic Redundancy Check
E	
ECU	Engine Control Unit
EGT	Exhaust Gas Temperature
EOP	Engine Oil Pressure
EOT	Engine Oil Temperature
F	
FFL	Fault Found
FMPLL	Frequency Modulation Phase Lock Loop
FPP	Fuel Pump Pressure
FPU	Floating Point Unavailable
FRP	Fuel Rail Pressure
FST	Field Service Tool

TROUBLESHOOTING GUIDE ABBREVIATIONS AND ACRONYMS (CONT.)

G	
GND	Ground
GPIO	General Purpose Input Output
GRA	General Random Access
H	
HSD	High Side Drive
I	
IVOR	Interrupt Vector Register
L	
LSD	Low Side Drive
M	
MAP	Manifold Absolute Pressure
MAT	Manifold Air Temperature
N	
NTO	No Take-Off
O	
OM	Operating Mode
Q	
QADC	Queued Analogue to Digital Converter.
R	
RPRA	Reset Persistent RAM
RTC	Real Time Clock
S	
SPE	Signal Processing Engine
SPI	Serial Peripheral Interface
T	
TLB	Translation Lookaside Buffer
TLO	Time-Limited Operation
TPU	Time Processing Unit
V	
VDC	Volts Direct Current

NOTICE: If the Troubleshooting Steps in this guide reference a procedure in another manual, the chapter and manual name will be specified. For example; Appendix A of the *TEO-540-A1A Engine Installation and Operation Manual*. If the Troubleshooting Steps reference a procedure in this Engine Maintenance Manual, only the chapter will be specified. For example; refer to the “Wiring Inspection” section in Chapter 72-70.



- NTO (PRI) – No Take-Off (Primary)
- NTO (SEC) – No Take-Off (Secondary)
- TLO – Time Limited Operation
- PFT – Pre-Flight Test (lamp and switch)
- FFL – Fault Found Lamp

Figure D-1
EECS Cockpit Controls and Annunciators

Fault Category	Operational Limitation
NTO – NO TAKE-OFF FAULTS	TAKE-OFF NOT ALLOWED WITH THIS CONDITION PRESENT. IF THE NTO ANNUNCIATOR ILLUMINATES DURING FLIGHT AND STAYS ILLUMINATED CONSTANTLY, LAND AS SOON AS SAFELY POSSIBLE. The NTO Annunciator must be within view of the pilot.
TLO – TIME- LIMITED OPERATION FAULTS	TAKE-OFF AND FLIGHT IS ALLOWED WITH TLO FAULTS PRESENT. All faults in this TLO category must be corrected within 20 hours of operation. 1. TLO Fault(s) which are present for 20 hours of operation will result in a NTO Fault. 2. If multiple TLO Faults are present, the first TLO fault to reach 20 hours of operation will trigger a NTO Fault. After which, all TLO Faults must be corrected before the NTO Fault can be cleared and the NTO Annunciator extinguished. The TLO Annunciator must be within view of the pilot.
FFL – FAULT FOUND LAMP	TAKE-OFF AND FLIGHT IS ALLOWED WITH FFL FAULTS PRESENT. All faults in this FFL category indicate a minor fault which has no effect on engine operation. All FFL faults must be corrected at or before the next scheduled engine inspection. The FFL Annunciator being within view of the pilot is optional. At a minimum, it must be accessible during maintenance and inspection events.

Fault ID	0	Fault Group	1	Fault Name	<i>RESERVED</i>
Fault Description:				Fault Lamp	N/A
Root Cause					
Troubleshooting Steps					

Fault ID	1	Fault Group	1	Fault Name	<i>[FAULT: Loss of Lock Reset]</i>
Fault Description:	Loss of FMPLL (Frequency Modulation Phase Lock Loop Lock) Reset circuitry			Fault Lamp	None
Root Cause	This fault indicates a hardware failure occurred during System Initialization.				
Troubleshooting Steps					
<ol style="list-style-type: none"> 1. With Ignition switch in OFF position, remove ECU power by pulling the ECU circuit breaker. Wait 10s before resetting. Is fault active? If no, go to step 2. If yes, replace the ECU. 2. Clear Service faults using the FST by following the steps outlined in the “Access the Field Service Tool” section in Appendix C or the latest revision of <i>SSP-118</i>. 3. If fault repeats, replace the ECU. 					

Fault ID	2	Fault Group	1	Fault Name	<i>[FAULT: Loss of Clock Reset]</i>
Fault Description	Loss of FMPLL clock reset			Fault Lamp	None
Root Cause	This fault indicates a failure of the FMPLL feature on the processor				
Troubleshooting Steps					
<ol style="list-style-type: none"> 1. With Ignition switch in OFF position, remove ECU power by pulling the ECU circuit breaker. Wait 10s before resetting. Is fault active? If no, go to step 2. If yes, replace the ECU. 2. Clear Service faults using the FST by following the steps outlined in the “Access the Field Service Tool” section in Appendix C or the latest revision of <i>SSP-118</i>. 3. If fault repeats, replace the ECU. 					

Fault ID	3	Fault Group	1	Fault Name	<i>[FAULT: Internal Watchdog Reset]</i>
Fault Description	Internal Watchdog Reset			Fault Lamp	None
Root Cause	This fault indicates a disabled reset has occurred. Internal processor watchdog timer reset has been disabled in the system by default.				
Troubleshooting Steps					
<ol style="list-style-type: none"> 1. With Ignition switch in OFF position, remove ECU power by pulling the ECU circuit breaker. Wait 10s before resetting. Is fault active? If no, go to step 2. If yes, replace the ECU. 2. Clear Service faults using the FST by following the steps outlined in the “Access the Field Service Tool” section in Appendix C or the latest revision of <i>SSP-118</i>. 3. If fault repeats, replace the ECU. 					

Fault ID	4	Fault Group	1	Fault Name	<i>[FAULT: Check stop Reset]</i>
Fault Description	Check stop Reset			Fault Lamp	None
Root Cause	This fault indicates a failure of the FMPLL feature on the processor				
Troubleshooting Steps					
<ol style="list-style-type: none"> 1. With Ignition switch in OFF position, remove ECU power by pulling the ECU circuit breaker. Wait 10s before resetting. Is fault active? If no, go to step 2. If yes, replace the ECU. 2. Clear Service faults using the FST by following the steps outlined in the “Access the Field Service Tool” section in Appendix C or the latest revision of <i>SSP-118</i>. 3. If fault repeats, replace the ECU. 					

Fault ID	5	Fault Group	1	Fault Name	<i>[FAULT: Watchdog Reset]</i>
Fault Description	External Watchdog Reset			Fault Lamp	None
Root Cause	External Watchdog Reset indicates the reset pin on the microcontroller was asserted				
Troubleshooting Steps					
<ol style="list-style-type: none"> 1. With Ignition switch in OFF position, remove ECU power by pulling the ECU circuit breaker. Wait 10s before resetting. Is fault active? If no, go to step 2. If yes, replace the ECU. 2. Clear Service faults using the FST by following the steps outlined in the “Access the Field Service Tool” section in Appendix C or the latest revision of <i>SSP-118</i>. 3. If fault repeats, replace the ECU. 					

Fault ID	6	Fault Group	1	Fault Name	<i>[FAULT: Software Reset]</i>
Fault Description	Software Reset			Fault Lamp	None
Root Cause	This fault indicates the software requested a system reset				
Troubleshooting Steps					
<ol style="list-style-type: none"> 1. With Ignition switch in OFF position, remove ECU power by pulling the ECU circuit breaker. Wait 10s before resetting. Is fault active? If no, go to step 2. If yes, replace the ECU. 2. Clear Service faults using the FST by following the steps outlined in the “Access the Field Service Tool” section in Appendix C or the latest revision of <i>SSP-118</i>. 3. If fault repeats, replace the ECU. 					

Fault ID	7	Fault Group	1	Fault Name	<i>[FAULT: Stack Monitor Overrun]</i>
Fault Description	Stack monitor overrun			Fault Lamp	None
Root Cause	This fault indicates the software has exceeded its Cache memory				
Troubleshooting Steps					
<ol style="list-style-type: none"> 1. With Ignition switch in OFF position, remove ECU power by pulling the ECU circuit breaker. Wait 10s before resetting. Is fault active? If no, go to step 2. If yes, replace the ECU. 2. Clear Service faults using the FST by following the steps outlined in the “Access the Field Service Tool” section in Appendix C or the latest revision of <i>SSP-118</i>. 3. If fault repeats, replace the ECU. 					

Fault ID	8	Fault Group	2	Fault Name	<i>[FAULT: APP CODE ERROR]</i>
Fault Description	Application code area corrupt			Fault Lamp	NTO
Root Cause	This fault indicates either failed attempt of application code CRC (Cyclic Redundancy Check) OR boot Code not in the expected memory range OR application code not in the expected memory range OR failed application version check. This fault may also indicate a broken hardware memory				
Troubleshooting Steps					
<ol style="list-style-type: none"> 1. With Ignition switch in OFF position, remove ECU power by pulling the ECU circuit breaker. Wait 10s before resetting. Is fault active? If no, go to step 3. If yes, go to step 2. 2. Contact Lycoming Personnel to reprogram the ECU. Is fault active or reprogram unsuccessful? If no, go to step 3. If yes, replace the ECU. 3. Clear Service faults using the FST by following the steps outlined in the “Access the Field Service Tool” section in Appendix C or the latest revision of <i>SSP-118</i>. 4. If fault repeats, replace the ECU. 					

Fault ID	9	Fault Group	2	Fault Name	<i>[FAULT: APP DATA ERROR]</i>
Fault Description	Application Calibration area corrupt			Fault Lamp	NTO
Root Cause	This fault indicates a possibility of either failed unit calibration block CRC check OR corrupted/failed memory. This fault may also indicate a broken hardware memory				
Troubleshooting Steps					
<ol style="list-style-type: none"> 1. With Ignition switch in OFF position, remove ECU power by pulling the ECU circuit breaker. Wait 10s before resetting. Is fault active? If no, go to step 3. If yes, go to step 2. 2. Contact Lycoming Personnel to reprogram the ECU. Is fault active or reprogram unsuccessful? If no, go to step 3. If yes, replace the ECU. 3. Clear Service faults using the FST by following the steps outlined in the “Access the Field Service Tool” section in Appendix C or the latest revision of <i>SSP-118</i>. 4. If fault repeats, replace the ECU. 					

Fault ID	10	Fault Group	2	Fault Name	<i>[FAULT: CACHE CORRUPT]</i>
Fault Description	CACHE memory corrupt			Fault Lamp	NTO
Root Cause	This fault indicates a possible CACHE memory corruption or failure				
Troubleshooting Steps					
<ol style="list-style-type: none"> 1. With Ignition switch in OFF position, remove ECU power by pulling the ECU circuit breaker. Wait 10s before resetting. Is fault active? If no, go to step 3. If yes, go to step 2. 2. Contact Lycoming Personnel to have the ECU reprogrammed. Is fault active or reprogram unsuccessful? If no, go to step 3. If yes, replace the ECU. 3. Clear Service faults using the FST by following the steps outlined in the “Access the Field Service Tool” section in Appendix C or the latest revision of <i>SSP-118</i>. 4. If fault repeats, replace the ECU. 					

Fault ID	11	Fault Group	2	Fault Name	<i>[FAULT: DATA TLB]</i>
Fault Description	TLB data access exception			Fault Lamp	NTO
Root Cause	This fault indicates an invalid entry from the data translation lookup into the TLB (Translation Lookaside Buffer) caused by a possible hardware issue (processor, memory corruption)				
Troubleshooting Steps					
<ol style="list-style-type: none"> 1. With Ignition switch in OFF position, remove ECU power by pulling the ECU circuit breaker. Wait 10s before resetting. Is fault active? If no, go to step 3. If yes, go to step 2. 2. Contact Lycoming Personnel to have the ECU reprogrammed. Is fault active or reprogram unsuccessful? If no, go to step 3. If yes, replace the ECU. 3. Clear Service faults using the FST by following the steps outlined in the “Access the Field Service Tool” section in Appendix C or the latest revision of <i>SSP-118</i>. 4. If fault repeats, replace the ECU. 					

Fault ID	12	Fault Group	2	Fault Name	<i>[FAULT: DEBUG]</i>
Fault Description	Debug Module Exception			Fault Lamp	NTO
Root Cause	This fault indicates a debug exception was received from processor possibly due to a hardware issue				
Troubleshooting Steps					
<ol style="list-style-type: none"> 1. With Ignition switch in OFF position, remove ECU power by pulling the ECU circuit breaker. Wait 10s before resetting. Is fault active? If no, go to step 3. If yes, go to step 2. 2. Contact Lycoming Personnel to have the ECU reprogrammed. Is fault active or reprogram unsuccessful? If no, go to step 3. If yes, replace the ECU. 3. Clear Service faults using the FST by following the steps outlined in the “Access the Field Service Tool” section in Appendix C or the latest revision of <i>SSP-118</i>. 4. If fault repeats, replace the ECU. 					

Fault ID	13	Fault Group	2	Fault Name	<i>[FAULT: GRA CORRUPT]</i>
Fault Description	GRA memory corrupt (Internal RAM)			Fault Lamp	NTO
Root Cause	This fault indicates a corrupted General On-Chip RAM area due to a processor issue. This is the On-Chip RAM excluding the shared Reset Persistent RAM area.				
Troubleshooting Steps					
<ol style="list-style-type: none"> 1. With Ignition switch in OFF position, remove ECU power by pulling the ECU circuit breaker. Wait 10s before resetting. Is fault active? If no, go to step 3. If yes, go to step 2. 2. Contact Lycoming Personnel to have the ECU reprogrammed. Is fault active or reprogram unsuccessful? If no, go to step 3. If yes, replace the ECU. 3. Clear Service faults using the FST by following the steps outlined in the “Access the Field Service Tool” section in Appendix C or the latest revision of <i>SSP-118</i>. 4. If fault repeats, replace the ECU. 					

Fault ID	14	Fault Group	2	Fault Name	<i>[FAULT: INSTRUCTION TLB]</i>
Fault Description	TLB instruction access exception			Fault Lamp	NTO
Root Cause	This fault indicates an invalid entry from the instruction translation lookup into the TLB (Translation Lookaside Buffer) caused by a possible hardware issue (processor, memory corruption)				
Troubleshooting Steps					
<ol style="list-style-type: none"> 1. With Ignition switch in OFF position, remove ECU power by pulling the ECU circuit breaker. Wait 10s before resetting. Is fault active? If no, go to step 3. If yes, go to step 2. 2. Contact Lycoming Personnel to have the ECU reprogrammed. Is fault active or reprogram unsuccessful? If no, go to step 3. If yes, replace the ECU. 3. Clear Service faults using the FST by following the steps outlined in the “Access the Field Service Tool” section in Appendix C or the latest revision of <i>SSP-118</i>. 4. If fault repeats, replace the ECU. 					

Fault ID	15	Fault Group	2	Fault Name	<i>[FAULT: MASTER CFG ERROR]</i>
Fault Description	Master configuration corrupt			Fault Lamp	NTO
Root Cause	This fault indicates a failed checksum for Master configuration block.				
Troubleshooting Steps					
<ol style="list-style-type: none"> 1. With Ignition switch in OFF position, remove ECU power by pulling the ECU circuit breaker. Wait 10s before resetting. Is fault active? If no, go to step 3. If yes, go to step 2. 2. Contact Lycoming Personnel to have the ECU reprogrammed. Is fault active or reprogram unsuccessful? If no, go to step 3. If yes, replace the ECU. 3. Clear Service faults using the FST by following the steps outlined in the “Access the Field Service Tool” section in Appendix C or the latest revision of <i>SSP-118</i>. 4. If fault repeats, replace the ECU. 					

Fault ID	16	Fault Group	3	Fault Name	<i>[FAULT: MACHINE CHECK]</i>
Fault Description	Machine Check Exception			Fault Lamp	NTO
Root Cause	This fault indicates a machine check exception Interrupt Vector Register 1 (IVOR1) from processor possibly due to a hardware issue.				
Troubleshooting Steps					
<ol style="list-style-type: none"> 1. With Ignition switch in OFF position, remove ECU power by pulling the ECU circuit breaker. Wait 10s before resetting. Is fault active? If no, go to step 3. If yes, go to step 2. 2. Contact Lycoming Personnel to have the ECU reprogrammed. Is fault active or reprogram unsuccessful? If no, go to step 3. If yes, replace the ECU. 3. Clear Service faults using the FST by following the steps outlined in the “Access the Field Service Tool” section in Appendix C or the latest revision of <i>SSP-118</i>. 4. If fault repeats, replace the ECU. 					

Fault ID	17	Fault Group	3	Fault Name	[FAULT: DATA STORE]
Fault Description	Data Store Exception			Fault Lamp	NTO
Root Cause	This fault indicates a data storage exception Interrupt Vector Register 2 (IVOR2) from processor possibly due to an ECU hardware issue.				
Troubleshooting Steps					
<ol style="list-style-type: none"> 1. With Ignition switch in OFF position, remove ECU power by pulling the ECU circuit breaker. Wait 10s before resetting. Is fault active? If no, go to step 3. If yes, go to step 2. 2. Contact Lycoming Personnel to have the ECU reprogrammed. Is fault active or reprogram unsuccessful? If no, go to step 3. If yes, replace the ECU. 3. Clear Service faults using the FST by following the steps outlined in the “Access the Field Service Tool” section in Appendix C or the latest revision of <i>SSP-118</i>. 4. If fault repeats, replace the ECU. 					

Fault ID	18	Fault Group	3	Fault Name	[FAULT: INSTRUCTION STORE]
Fault Description	Instruction Read Exception			Fault Lamp	NTO
Root Cause	This fault indicates an instruction storage exception Interrupt Vector Register 3 (IVOR3) from processor possibly due to an ECU hardware issue.				
Troubleshooting Steps					
<ol style="list-style-type: none"> 1. With Ignition switch in OFF position, remove ECU power by pulling the ECU circuit breaker. Wait 10s before resetting. Is fault active? If no, go to step 3. If yes, go to step 2. 2. Contact Lycoming Personnel to have the ECU reprogrammed. Is fault active or reprogram unsuccessful? If no, go to step 3. If yes, replace the ECU. 3. Clear Service faults using the FST by following the steps outlined in the “Access the Field Service Tool” section in Appendix C or the latest revision of <i>SSP-118</i>. 4. If fault repeats, replace the ECU. 					

Fault ID	19	Fault Group	3	Fault Name	[FAULT: UNDEFINED INTERRUPT]
Fault Description	Undefined Module Interrupt Exception			Fault Lamp	NTO
Root Cause	This fault indicates an undefined external interrupt exception Interrupt Vector Register 4 (IVOR4) from processor possibly due to an ECU hardware issue.				
Troubleshooting Steps					
<ol style="list-style-type: none"> 1. With Ignition switch in OFF position, remove ECU power by pulling the ECU circuit breaker. Wait 10s before resetting. Is fault active? If no, go to step 3. If yes, go to step 2. 2. Contact Lycoming Personnel to have the ECU reprogrammed. Is fault active or reprogram unsuccessful? If no, go to step 3. If yes, replace the ECU. 3. Clear Service faults using the FST by following the steps outlined in the “Access the Field Service Tool” section in Appendix C or the latest revision of <i>SSP-118</i>. 4. If fault repeats, replace the ECU. 					

Fault ID	20	Fault Group	3	Fault Name	<i>[FAULT: ALIGNMENT]</i>
Fault Description	Memory Alignment Exception			Fault Lamp	NTO
Root Cause	This fault indicates an alignment exception Interrupt Vector Register 5 (IVOR5) from processor possibly due to an ECU hardware issue.				
Troubleshooting Steps					
<ol style="list-style-type: none"> 1. With Ignition switch in OFF position, remove ECU power by pulling the ECU circuit breaker. Wait 10s before resetting. Is fault active? If no, go to step 3. If yes, go to step 2. 2. Contact Lycoming Personnel to have the ECU reprogrammed. Is fault active or reprogram unsuccessful? If no, go to step 3. If yes, replace the ECU. 3. Clear Service faults using the FST by following the steps outlined in the “Access the Field Service Tool” section in Appendix C or the latest revision of <i>SSP-118</i>. 4. If fault repeats, replace the ECU. 					

Fault ID	21	Fault Group	3	Fault Name	<i>[FAULT: PROGRAM]</i>
Fault Description	Program Exception			Fault Lamp	NTO
Root Cause	This fault indicates a program exception Interrupt Vector Register 6 (IVOR6) from processor possibly due to an ECU hardware issue.				
Troubleshooting Steps					
<ol style="list-style-type: none"> 1. With Ignition switch in OFF position, remove ECU power by pulling the ECU circuit breaker. Wait 10s before resetting. Is fault active? If no, go to step 3. If yes, go to step 2. 2. Contact Lycoming Personnel to have the ECU reprogrammed. Is fault active or reprogram unsuccessful? If no, go to step 3. If yes, replace the ECU. 3. Clear Service faults using the FST by following the steps outlined in the “Access the Field Service Tool” section in Appendix C or the latest revision of <i>SSP-118</i>. 4. If fault repeats, replace the ECU. 					

Fault ID	22	Fault Group	3	Fault Name	<i>[FAULT: FPU]</i>
Fault Description	FPU Exception			Fault Lamp	NTO
Root Cause	This fault indicates a Floating Point Unavailable exception Interrupt Vector Register 7 (IVOR7) possibly due to an ECU hardware issue.				
Troubleshooting Steps					
<ol style="list-style-type: none"> 1. With Ignition switch in OFF position, remove ECU power by pulling the ECU circuit breaker. Wait 10s before resetting. Is fault active? If no, go to step 3. If yes, go to step 2. 2. Contact Lycoming Personnel to have the ECU reprogrammed. Is fault active or reprogram unsuccessful? If no, go to step 3. If yes, replace the ECU. 3. Clear Service faults using the FST by following the steps outlined in the “Access the Field Service Tool” section in Appendix C or the latest revision of <i>SSP-118</i>. 4. If fault repeats, replace the ECU. 					

Fault ID	23	Fault Group	3	Fault Name	<i>[FAULT: SYSTEM]</i>
Fault Description	System Call Exception			Fault Lamp	NTO
Root Cause	This fault indicates a System call exception Interrupt Vector Register 8 (IVOR8) possibly due to an ECU hardware issue.				
Troubleshooting Steps					
<ol style="list-style-type: none"> 1. With Ignition switch in OFF position, remove ECU power by pulling the ECU circuit breaker. Wait 10s before resetting. Is fault active? If no, go to step 3. If yes, go to step 2. 2. Contact Lycoming Personnel to have the ECU reprogrammed. Is fault active or reprogram unsuccessful? If no, go to step 3. If yes, replace the ECU. 3. Clear Service faults using the FST by following the steps outlined in the “Access the Field Service Tool” section in Appendix C or the latest revision of <i>SSP-118</i>. 4. If fault repeats, replace the ECU. 					

Fault ID	24	Fault Group	4	Fault Name	<i>[FAULT: RPRA CORRUPT]</i>
Fault Description	RPRA memory corruption (Internal RAM)			Fault Lamp	NTO
Root Cause	This fault indicates a corrupted Reset Persistent RAM area due a possible ECU hardware issue.				
Troubleshooting Steps					
<ol style="list-style-type: none"> 1. With Ignition switch in OFF position, remove ECU power by pulling the ECU circuit breaker. Wait 10s before resetting. Is fault active? If no, go to step 3. If yes, go to step 2. 2. Contact Lycoming Personnel to have the ECU reprogrammed. Is fault active or reprogram unsuccessful? If no, go to step 3. If yes, replace the ECU. 3. Clear Service faults using the FST by following the steps outlined in the “Access the Field Service Tool” section in Appendix C or the latest revision of <i>SSP-118</i>. 4. If fault repeats, replace the ECU. 					

Fault ID	25	Fault Group	4	Fault Name	<i>[FAULT: RPRA INCOMPLETE EXCEPTION]</i>
Fault Description	RPRA (Reset Persistent RAM) area not validated during exception processing			Fault Lamp	NTO
Root Cause	This fault indicates an interruption caused by an exception during a write event to the shared RPRA. The fault was triggered due to a possible ECU hardware issue.				
Troubleshooting Steps					
<ol style="list-style-type: none"> 1. With Ignition switch in OFF position, remove ECU power by pulling the ECU circuit breaker. Wait 10s before resetting. Is fault active? If no, go to step 3. If yes, go to step 2. 2. Contact Lycoming Personnel to have the ECU reprogrammed. Is fault active or reprogram unsuccessful? If no, go to step 3. If yes, replace the ECU. 3. Clear Service faults using the FST by following the steps outlined in the “Access the Field Service Tool” section in Appendix C or the latest revision of <i>SSP-118</i>. 4. If fault repeats, replace the ECU. 					

Fault ID	26	Fault Group	4	Fault Name	<i>[FAULT: RPRA INVALID EXCEPTION]</i>
Fault Description	RPRA area invalid during exception processing			Fault Lamp	NTO
Root Cause	This fault indicates an exception or interrupt occurred before the RPRA was tested and initialized. This should prompt the boot code to initialize the RPRA. The fault was triggered due to an ECU hardware issue.				
Troubleshooting Steps					
<ol style="list-style-type: none"> 1. With Ignition switch in OFF position, remove ECU power by pulling the ECU circuit breaker. Wait 10s before resetting. Is fault active? If no, go to step 3. If yes, go to step 2. 2. Contact Lycoming Personnel to have the ECU reprogrammed. Is fault active or reprogram unsuccessful? If no, go to step 3. If yes, replace the ECU. 3. Clear Service faults using the FST by following the steps outlined in the “Access the Field Service Tool” section in Appendix C or the latest revision of <i>SSP-118</i>. 4. If fault repeats, replace the ECU. 					

Fault ID	27	Fault Group	4	Fault Name	<i>[FAULT: RPRA INVALID]</i>
Fault Description	RPRA area is not coherent			Fault Lamp	NTO
Root Cause	This fault indicates the RPRA contains an invalid data possibly due to an ECU hardware issue.				
Troubleshooting Steps					
<ol style="list-style-type: none"> 1. With Ignition switch in OFF position, remove ECU power by pulling the ECU circuit breaker. Wait 10s before resetting. Is fault active? If no, go to step 3. If yes, go to step 2. 2. Contact Lycoming Personnel to have the ECU reprogrammed. Is fault active or reprogram unsuccessful? If no, go to step 3. If yes, replace the ECU. 3. Clear Service faults using the FST by following the steps outlined in the “Access the Field Service Tool” section in Appendix C or the latest revision of <i>SSP-118</i>. 4. If fault repeats, replace the ECU. 					

Fault ID	28	Fault Group	4	Fault Name	<i>[FAULT: SPE]</i>
Fault Description	SPE Exception			Fault Lamp	NTO
Root Cause	This fault indicates a SPE (Signal Processing Engine) Floating Point data exception or inexact result from floating-point instruction possibly due to an ECU hardware issue.				
Troubleshooting Steps					
<ol style="list-style-type: none"> 1. With Ignition switch in OFF position, remove ECU power by pulling the ECU circuit breaker. Wait 10s before resetting. Is fault active? If no, go to step 3. If yes, go to step 2. 2. Contact Lycoming Personnel to have the ECU reprogrammed. Is fault active or reprogram unsuccessful? If no, go to step 3. If yes, replace the ECU. 3. Clear Service faults using the FST by following the steps outlined in the “Access the Field Service Tool” section in Appendix C or the latest revision of <i>SSP-118</i>. 4. If fault repeats, replace the ECU. 					

Fault ID	29	Fault Group	4	Fault Name	<i>[FAULT: TPU failure]</i>
Fault Description	Application TPU exception			Fault Lamp	NTO
Root Cause	This fault indicates a failed attempt to initialize TPU (Time Processing Unit) or an inexact result from floating-point instruction possibly due to an ECU hardware issue.				
Troubleshooting Steps					
<ol style="list-style-type: none"> 1. With Ignition switch in OFF position, remove ECU power by pulling the ECU circuit breaker. Wait 10s before resetting. Is fault active? If no, go to step 3. If yes, go to step 2. 2. Contact Lycoming Personnel to have the ECU reprogrammed. Is fault active or reprogram unsuccessful? If no, go to step 3. If yes, replace the ECU. 3. Clear Service faults using the FST by following the steps outlined in the “Access the Field Service Tool” section in Appendix C or the latest revision of <i>SSP-118</i>. 4. If fault repeats, replace the ECU. 					

Fault ID	30	Fault Group	4	Fault Name	<i>[FAULT: UNITCAL ERROR]</i>
Fault Description	Factory Calibration area corrupt			Fault Lamp	NTO
Root Cause	This fault indicates a failed checksum for Unit Factory Calibration due to a corrupted boot and application code OR a possible ECU hardware issue.				
Troubleshooting Steps					
<ol style="list-style-type: none"> 1. With Ignition switch in OFF position, remove ECU power by pulling the ECU circuit breaker. Wait 10s before resetting. Is fault active? If no, go to step 3. If yes, go to step 2. 2. Contact Lycoming Personnel to have the ECU reprogrammed. Is fault active or reprogram unsuccessful? If no, go to step 3. If yes, replace the ECU. 3. Clear Service faults using the FST by following the steps outlined in the “Access the Field Service Tool” section in Appendix C or the latest revision of <i>SSP-118</i>. 4. If fault repeats, replace the ECU. 					

Fault ID	31	Fault Group	4	Fault Name	<i>[FAULT: UNSUPPORTED INTERRUPT]</i>
Fault Description	Unsupported Interrupt occurred			Fault Lamp	NTO
Root Cause	This fault indicates an unsupported interrupt was received possibly due to an ECU hardware issue				
Troubleshooting Steps					
<ol style="list-style-type: none"> 1. With Ignition switch in OFF position, remove ECU power by pulling the ECU circuit breaker. Wait 10s before resetting. Is fault active? If no, go to step 3. If yes, go to step 2. 2. Contact Lycoming Personnel to have the ECU reprogrammed. Is fault active or reprogram unsuccessful? If no, go to step 3. If yes, replace the ECU. 3. Clear Service faults using the FST by following the steps outlined in the “Access the Field Service Tool” section in Appendix C or the latest revision of <i>SSP-118</i>. 4. If fault repeats, replace the ECU. 					

Fault ID	32	Fault Group	5	Fault Name	<i>[FAULT: 100ms task overrun]</i>
Fault Description	Application 100ms task overrun			Fault Lamp	None
Root Cause	The fault indicates a delay in execution/completion of a 100ms periodic task before the request/scheduling of the next 100ms periodic task due to possible hardware interrupts				
Troubleshooting Steps					
<ol style="list-style-type: none"> 1. With Ignition switch in OFF position, remove ECU power by pulling the ECU circuit breaker. Wait 10s before resetting. Is fault active? If no, go to step 2. If yes, replace the ECU. 2. Clear Service faults using the FST by following the steps outlined in the “Access the Field Service Tool” section in Appendix C or the latest revision of <i>SSP-118</i>. 3. If fault repeats, replace the ECU. 					

Fault ID	33	Fault Group	5	Fault Name	<i>[FAULT: 10ms task overrun]</i>
Fault Description	Application 10ms task overrun			Fault Lamp	None
Root Cause	The fault indicates a delay in execution/completion of a 10ms periodic task before the request/scheduling of the next 10ms periodic task due to possible hardware interrupts				
Troubleshooting Steps					
<ol style="list-style-type: none"> 1. With Ignition switch in OFF position, remove ECU power by pulling the ECU circuit breaker. Wait 10s before resetting. Is fault active? If no, go to step 2. If yes, replace the ECU. 2. Clear Service faults using the FST by following the steps outlined in the “Access the Field Service Tool” section in Appendix C or the latest revision of <i>SSP-118</i>. 3. If fault repeats, replace the ECU. 					

Fault ID	34	Fault Group	5	Fault Name	<i>[FAULT: 1ms task overrun]</i>
Fault Description	Application 1ms task overrun			Fault Lamp	None
Root Cause	The fault indicates a delay in execution/completion of a 1ms periodic task before the request/scheduling of the next 1ms periodic task due to possible hardware interrupts				
Troubleshooting Steps					
<ol style="list-style-type: none"> 1. With Ignition switch in OFF position, remove ECU power by pulling the ECU circuit breaker. Wait 10s before resetting. Is fault active? If no, go to step 2. If yes, replace the ECU. 2. Clear Service faults using the FST by following the steps outlined in the “Access the Field Service Tool” section in Appendix C or the latest revision of <i>SSP-118</i>. 3. If fault repeats, replace the ECU. 					

Fault ID	35	Fault Group	5	Fault Name	<i>[FAULT: TASK OVERRUN]</i>
Fault Description	Application task overrun causing reset			Fault Lamp	None
Root Cause	The fault indicates more consecutive tasks overruns than allowed due to possible hardware interrupts				
Troubleshooting Steps					
<ol style="list-style-type: none"> 1. With Ignition switch in OFF position, remove ECU power by pulling the ECU circuit breaker. Wait 10s before resetting. Is fault active? If no, go to step 2. If yes, replace the ECU. 2. Clear Service faults using the FST by following the steps outlined in the “Access the Field Service Tool” section in Appendix C or the latest revision of <i>SSP-118</i>. 3. If fault repeats, replace the ECU. 					

Fault ID	36	Fault Group	5	Fault Name	<i>[FAULT: sync task overrun]</i>
Fault Description	Application sync task overrun			Fault Lamp	None
Root Cause	The fault indicates a delay in execution/completion of a sync task before the request/scheduling of the next sync periodic task due to possible hardware interrupts				
Troubleshooting Steps					
<ol style="list-style-type: none"> 1. With Ignition switch in OFF position, remove ECU power by pulling the ECU circuit breaker. Wait 10s before resetting. Is fault active? If no, go to step 2. If yes, replace the ECU. 2. Clear Service faults using the FST by following the steps outlined in the “Access the Field Service Tool” section in Appendix C or the latest revision of <i>SSP-118</i>. 3. If fault repeats, replace the ECU. 					

Fault ID	37	Fault Group	5	Fault Name	<i>[FAULT: task scheduler overrun]</i>
Fault Description	Application task scheduler overrun			Fault Lamp	None
Root Cause	The fault indicates a delay in execution/completion of a scheduler task before the request/scheduling of the next scheduler task due to possible hardware interrupts				
Troubleshooting Steps					
<ol style="list-style-type: none"> 1. With Ignition switch in OFF position, remove ECU power by pulling the ECU circuit breaker. Wait 10s before resetting. Is fault active? If no, go to step 2. If yes, replace the ECU. 2. Clear Service faults using the FST by following the steps outlined in the “Access the Field Service Tool” section in Appendix C or the latest revision of <i>SSP-118</i>. 3. If fault repeats, replace the ECU. 					

Fault ID	38	Fault Group	5	Fault Name	<i>-reserved-</i>
Fault Description				Fault Lamp	None
Root Cause					
Troubleshooting Steps					

Fault ID	39	Fault Group	5	Fault Name	<i>-reserved-</i>
Fault Description				Fault Lamp	None
Root Cause					
Troubleshooting Steps					

Fault ID	40	Fault Group	6	Fault Name	<i>[FAULT: Cylinder 1 inoperative cylinder detected]</i>
Fault Description	Cylinder 1 detected as inoperative			Fault Lamp	NTO
Fault ID	41	Fault Group	6	Fault Name	<i>[FAULT: Cylinder 2 inoperative cylinder detected]</i>
Fault Description	Cylinder 2 detected as inoperative			Fault Lamp	NTO
Fault ID	42	Fault Group	6	Fault Name	<i>[FAULT: Cylinder 3 inoperative cylinder detected]</i>
Fault Description	Cylinder 3 detected as inoperative			Fault Lamp	NTO
Fault ID	43	Fault Group	6	Fault Name	<i>[FAULT: Cylinder 4 inoperative cylinder detected]</i>
Fault Description	Cylinder 4 detected as inoperative			Fault Lamp	NTO
Fault ID	44	Fault Group	6	Fault Name	<i>[FAULT: Cylinder 5 inoperative cylinder detected]</i>
Fault Description	Cylinder 5 detected as inoperative			Fault Lamp	NTO
Fault ID	45	Fault Group	6	Fault Name	<i>[FAULT: Cylinder 6 inoperative cylinder detected]</i>
Fault Description	Cylinder 6 detected as inoperative			Fault Lamp	NTO
Fault ID	46	Fault Group	6	Fault Name	<i>[FAULT: Cylinder 7 inoperative cylinder detected]</i>
Fault Description	Cylinder 7 detected as inoperative			Fault Lamp	NTO
Fault ID	47	Fault Group	6	Fault Name	<i>[FAULT: Cylinder 8 inoperative cylinder detected]</i>
Fault Description	Cylinder 8 detected as inoperative			Fault Lamp	NTO
Root Cause	The fault indicates EGT1 and CHT1 has been below the minimum threshold. The fault will become inactive if the cylinder starts operating as expected again (CHT 1 OR EGT 1 above the minimum threshold level)				
Troubleshooting Steps for Faults 40 thru 47					
<ol style="list-style-type: none"> 1. Run the engine in accordance with the engine and aircraft maintenance manuals. Is the fault active? If yes, does the behavior of the engine correspond to the fault? This can be confirmed by checking the aircraft CHT instrument. Is there an CHT reading on the instrument? If yes, is it within 50° of the other cylinders? If yes, go to step 2. If the fault is not active, but the engine is not operating normally, or the CHT is more than 50° cooler than the other cylinders, go to step 2. If the fault is not active, and there are no other associated faults (as outlined in step 3), and the engine is operating normally, inspect cabling and connections in accordance with the harness inspection in the engine maintenance manual. 2. Using the FST, download active and service fault logs. 3. Review logs to determine if there are any faults for the following sub-systems in the active or service fault logs: <ol style="list-style-type: none"> a. EGT b. CHT c. Ignition d. Fuel Injector <p>If faults are found for steps 3a and/or 3b, perform steps 4 and 5, and 6. If faults are found for step 3c, perform step 7 and 8. If faults found for step 3d, perform step 9.</p>					

Troubleshooting Steps for Faults 40 thru 47 (Cont.)

4. Inspect CHT and EGT sensors, and leads for any damage (eg...burned, broken or frayed wires, cracked or broken connectors, burned or broken sensors). Replace any damaged sensors in accordance with the engine maintenance manual.
5. Inspect CHT and EGT harness connections for any damage (eg...burned, broken or frayed wires, cracked or broken connectors). Contact Lycoming if harness damage is found.
6. Swap the sensor from the channel giving the fault with another sensor on a different cylinder. Does the fault move with the sensor? If so, replace the sensor in accordance with the engine maintenance manual. If the fault does not move, perform a continuity test of the harness from the harness sensor connector to the ECU connector using the engine system schematic. If continuity check fails, isolate to affected harness by disconnecting the firewall connection, then contact Lycoming Engines. If continuity checks good, go to next step.
7. Inspect spark plugs and leads in accordance with the maintenance manual and clean or replace as needed.
8. If spark plug and leads check good, remove cover from coil box, remove connector from coil of affected cylinder, and check for 14 VDC on pin A of the harness coil connector (with power applied to EEC system). If 14 VDC is present, swap coil with another cylinder. Does fault move with coil? If so, replace coil in accordance with engine maintenance manual. If 14 VDC is not present, or the fault does not move with the coil, perform a continuity test of the harness from the harness coil connector to the ECU and APU connectors using the engine system schematic. If continuity check fails, isolate to affected harness by disconnecting the firewall connection, then contact Lycoming Engines. If continuity check passes, but 14 VDC is not present, contact Lycoming Engines for replacement of the APU. If all checks pass, go to next step.
9. Swap fuel injector of the affected cylinder with another cylinder. Run the engine. Does the fault move with the injector? If so, replace the injector. If the fault does not move, perform a continuity test of the harness from the harness injector connector to the ECU using the engine system schematic. If continuity check fails, isolate to affected harness by disconnecting the firewall connection, then contact Lycoming Engines. If continuity check passes, go to step 7.
10. If all above steps check good, perform a compression check in accordance with the maintenance manual.
11. If all steps pass, contact Lycoming Engines.

Fault ID	48	Fault Group	7	Fault Name	<i>[FAULT: Cylinder 1 detonation detected]</i>
Fault Description	Cylinder 1 excessive detonation detected			Fault Lamp	NT0
Fault ID	49	Fault Group	7	Fault Name	<i>[FAULT: Cylinder 2 detonation detected]</i>
Fault Description	Cylinder 2 excessive detonation detected			Fault Lamp	NT0
Fault ID	50	Fault Group	7	Fault Name	<i>[FAULT: Cylinder 3 detonation detected]</i>
Fault Description	Cylinder 3 excessive detonation detected			Fault Lamp	NT0
Fault ID	51	Fault Group	7	Fault Name	<i>[FAULT: Cylinder 4 detonation detected]</i>
Fault Description	Cylinder 4 excessive detonation detected			Fault Lamp	NT0
Fault ID	52	Fault Group	7	Fault Name	<i>[FAULT: Cylinder 5 detonation detected]</i>
Fault Description	Cylinder 5 excessive detonation detected			Fault Lamp	NT0

Fault ID	53	Fault Group	7	Fault Name	<i>[FAULT: Cylinder 6 detonation detected]</i>
Fault Description	Cylinder 6 excessive detonation detected			Fault Lamp	NTO
Fault ID	54	Fault Group	7	Fault Name	<i>[FAULT: Cylinder 7 detonation detected]</i>
Fault Description	Cylinder 7 excessive detonation detected			Fault Lamp	NTO
Fault ID	55	Fault Group	7	Fault Name	<i>[FAULT: Cylinder 8 detonation detected]</i>
Fault Description	Cylinder 8 excessive detonation detected			Fault Lamp	NTO
Root Cause	The fault indicates that the number of detected detonation events for the cylinder over the most recent 100 firing cycles has exceeded the calibrated threshold. The fault will become inactive if the number of detected detonation events fall back under the threshold				

Troubleshooting Steps for Faults 48 thru 55

1. Run the engine in accordance with the engine and aircraft maintenance manuals. Is the fault active? If yes, does the behavior of the engine correspond to the fault (Is it knocking)? If yes, is it detonating on more than one cylinder? If yes to all questions, go to step 2. If there is no detonation, go to step 4.
2. Using the FST, download active and service fault logs.
3. Review logs to determine if there are any faults for the following sub-systems in the active or service fault logs and go to the step that corresponds to the fault:
 - a. Fuel Pump
 - b. Injector
 If faults are found for step 3a, complete steps 5 and 6. If faults are found for step 3b, complete step 7.
4. Swap detonation sensor with another cylinder. If fault does not move with sensor, complete a continuity check of harness from knock sensor connector to ECU connector using the engine system schematic. If the continuity check fails, isolate to affected harness by disconnecting firewall harness and repeating the continuity check, then contact Lycoming Engines. If the continuity check passes, go to step 5.
5. Verify appropriate engine fuel outlet pressure and fuel rail pressure are achieved per Appendix A of the *TEO-540-A1A Installation and Operation Manual*.
6. Inspect aircraft fuel system for any blockage that may result in fuel starvation at the fuel rails per the "Fuel System Inspection Checklist in Chapter 73-10 and purge the fuel system if necessary.
7. Verify fuel injector connector is seated on injector. If so, swap injector with another cylinder. Does the fault move with the injector? If yes, replace the injector. If no, complete a continuity check of harness from fuel injector connector to ECU connector using the engine system schematic. If the continuity check fails, isolate to affected harness by disconnecting firewall harness and repeating the continuity check, then contact Lycoming Engines.

Fault ID	56	Fault Group	8	Fault Name	<i>[FAULT: Cylinder 1 CHT over temperature]</i>
Fault Description	Cylinder 1 excessive CHT			Fault Lamp	TLO
Fault ID	57	Fault Group	8	Fault Name	<i>[FAULT: Cylinder 2 CHT over temperature]</i>
Fault Description	Cylinder 2 excessive CHT			Fault Lamp	TLO
Fault ID	58	Fault Group	8	Fault Name	<i>[FAULT: Cylinder 3 CHT over temperature]</i>
Fault Description	Cylinder 3 excessive CHT			Fault Lamp	TLO

Fault ID	59	Fault Group	8	Fault Name	<i>[FAULT: Cylinder 4 CHT over temperature]</i>
Fault Description	Cylinder 4 excessive CHT			Fault Lamp	TLO
Fault ID	60	Fault Group	8	Fault Name	<i>[FAULT: Cylinder 5 CHT over temperature]</i>
Fault Description	Cylinder 5 excessive CHT			Fault Lamp	TLO
Fault ID	61	Fault Group	8	Fault Name	<i>[FAULT: Cylinder 6 CHT over temperature]</i>
Fault Description	Cylinder 6 excessive CHT			Fault Lamp	TLO
Fault ID	62	Fault Group	8	Fault Name	<i>[FAULT: Cylinder 7 CHT over temperature]</i>
Fault Description	Cylinder 7 excessive CHT			Fault Lamp	TLO
Fault ID	63	Fault Group	8	Fault Name	<i>[FAULT: Cylinder 8 CHT over temperature]</i>
Fault Description	Cylinder 8 excessive CHT			Fault Lamp	TLO
Root Cause	This fault indicates the CHT (Cylinder Head Temperature) has consistently exceeded its maximum temperature limit prescribed in Appendix A of the <i>TEO-540-A1A Engine Installation and Operation Manual</i> . This fault will become inactive once the CHT is below the maximum limit				
Troubleshooting Steps for Faults 56 thru 63					
<ol style="list-style-type: none"> 1. Run the engine in accordance with the engine and aircraft maintenance manuals. Is the fault active? If yes, continue. If no, go to step 3. Does the behavior of the engine correspond to the fault? If yes, are other CHT showing higher than normal with or without a fault? If yes, go to step 2. If no to engine behavior or other CHT's, go to step 5. 2. Inspect engine and airframe baffles to ensure that there are no leaks. If no defects or leaks found, go to step 3. 3. Using the FST, download active and service fault logs. 4. Review logs to determine if there are any faults for the following sub-systems in the active or service fault logs and go to the step that corresponds to the fault: <ol style="list-style-type: none"> a. CHT b. Induction System (MAP, CIP, Deck Pressure) c. Fuel d. Injector <p>If faults are found for step 4a, complete steps 5 and 6. If faults are found for step 4b, complete step 8. If faults found for step 4c, complete step 9. If faults are found for step 4d, complete step 10.</p> 5. Inspect CHT sensor, and lead for any damage (eg...burned, broken or frayed wires, cracked or broken connectors, burned or broken sensors). Replace any damaged sensors per the "Sensor Replacement Procedures" section in Chapter 72-70. If sensor is good, go to step 6. 6. Inspect CHT harness connection for any damage (eg...burned, broken or frayed wires, cracked or broken connectors). Contact Lycoming if harness damage is found. 7. If steps 5 and 6 check good, swap the sensor from the channel giving the fault with another sensor on a different cylinder. Does the fault move with the sensor? If so, replace the sensor per the "Sensor Replacement Procedures" section in Chapter 72-70. If the fault does not move, complete a continuity test of the harness from the harness sensor connector to the ECU connector using the engine system schematic. If the continuity check fails, isolate to affected harness by disconnecting the firewall connection, then contact Lycoming Engines. If the continuity checks good, go to next step. 8. Inspect for any induction leak. If no leaks are found, refer to troubleshooting for fault recorded in step 4. 					

Troubleshooting Steps for Faults 56 thru 63 (Cont.)

9. Inspect aircraft fuel system for any blockage that may result in fuel starvation at the fuel rails per the "Fuel System Inspection Checklist in Chapter 73-10 and purge the fuel system if necessary. If fuel system checks good, refer to troubleshooting for fault recorded in step 4.
10. Verify fuel injector connector is seated on injector. If so, swap injector with another cylinder. Does the fault move with the injector? If yes, replace the injector. If no, complete a continuity check of harness from fuel injector connector to ECU connector using the engine system schematic. If the continuity check fails, isolate to affected harness by disconnecting firewall harness and repeating the continuity check, then contact Lycoming Engines.

Fault ID	64	Fault Group	9	Fault Name	<i>[FAULT: Cylinder 1 ignition output failure]</i>
Fault Description	Cylinder 1 Ignition output failure			Fault Lamp	TLO
Fault ID	65	Fault Group	9	Fault Name	<i>[FAULT: Cylinder 2 ignition output failure]</i>
Fault Description	Cylinder 2 Ignition output failure			Fault Lamp	TLO
Fault ID	66	Fault Group	9	Fault Name	<i>[FAULT: Cylinder 3 ignition output failure]</i>
Fault Description	Cylinder 3 Ignition output failure			Fault Lamp	TLO
Fault ID	67	Fault Group	9	Fault Name	<i>[FAULT: Cylinder 4 ignition output failure]</i>
Fault Description	Cylinder 4 Ignition output failure			Fault Lamp	TLO
Fault ID	68	Fault Group	9	Fault Name	<i>[FAULT: Cylinder 5 ignition output failure]</i>
Fault Description	Cylinder 5 Ignition output failure			Fault Lamp	TLO
Fault ID	69	Fault Group	9	Fault Name	<i>[FAULT: Cylinder 6 ignition output failure]</i>
Fault Description	Cylinder 6 Ignition output failure			Fault Lamp	TLO
Fault ID	70	Fault Group	9	Fault Name	<i>[FAULT: Cylinder 7 ignition output failure]</i>
Fault Description	Cylinder 7 Ignition output failure			Fault Lamp	TLO
Fault ID	71	Fault Group	9	Fault Name	<i>[FAULT: Cylinder 8 ignition output failure]</i>
Fault Description	Cylinder 8 Ignition output failure			Fault Lamp	TLO
Root Cause	This fault occurs when a circuit fault is consistently detected on the Ignition Driver. This fault is an indication of an incorrect current feedback indicated to the TPU (zero current in case of Open Circuit detection and higher than a threshold current for Short Circuit detection)				

Troubleshooting Steps for Faults 64 thru 71

1. Run the engine in accordance with the engine and aircraft maintenance manuals. Is the fault active? If yes, continue. If no, go to step 4. Are there active faults for other cylinders? If yes, go to step 6. If no, go to step 2.

Troubleshooting Steps for Faults 64 thru 71 (Cont.)

2. Inspect spark plugs and leads per the “Ignition Lead Inspection” and “Spark Plug Inspection” sections in Chapter 74-20 and replace any spark plug or cable that does not meet serviceability requirements. If all plugs and leads pass inspection, swap spark plug of affected ignition circuit with a spark plug from another cylinder. Does the fault move with the spark plug? If yes, replace the spark plug. If no, swap the cable of the affected ignition circuit with another cable with similar length so both can be reconnected. Does the fault move with the cable? If yes, replace the cable. If no, go to step 3.
3. Remove the coil box cover, swap the coil of the affected ignition circuit with a coil from another cylinder. Does the fault follow the coil? If yes, replace the coil. If no, go to step 8.
4. Using the FST, download active and service fault logs.
5. Review logs to determine which fault was set, and if there are more than one fault. If there are no active faults, but fault(s) keep reoccurring, then if one fault, go to step 2. If multiple faults, go to step 5.
6. If multiple cylinders were found to be malfunctioning in step 1, are they malfunctioning in groups as shown below?

Group 1 (Pri)	Group 2 (Sec)	Group 3 (Sec)	Group 4 (Pri)
1T	2T	1B	2B
3T	4T	3B	4B
5T	6T	5B	6B

7. If yes, remove the coil box cover, disconnect all applicable harness coil connectors (Group 1, 2, 3, or 4), apply power to the aircraft, turn on the ignition and check for 14VDC on pin A of each coil connector. Is 14 VDC present on one or all malfunctioning coils? If 14 VDC is present on at least one, but not three, complete a continuity test of the harness from each of the harness coil connectors to the ECU and Power Box connectors using the engine system schematic. * If the continuity check fails, isolate to affected harness by disconnecting the firewall connection, then contact Lycoming Engines. If the continuity checks good, or if 14 VDC is not present, replace the Power Box.
8. Complete a continuity test of the harness from the harness coil connector to the ECU and Power Box connectors using the engine system schematic. If the continuity check fails, isolate to affected harness by disconnecting the firewall connection, then contact Lycoming Engines. If the continuity check is good, replace the ECU.

*NOTE: When performing the continuity check, ensure all coils for the group are disconnected to prevent false continuity by reading through another coil.

Fault ID	72	Fault Group	10	Fault Name	<i>[FAULT: Cylinder 1 injection output failure]</i>
Fault Description	Cylinder 1 injection output failure			Fault Lamp	NTO
Fault ID	73	Fault Group	10	Fault Name	<i>[FAULT: Cylinder 2 injection output failure]</i>
Fault Description	Cylinder 2 injection output failure			Fault Lamp	NTO
Fault ID	74	Fault Group	10	Fault Name	<i>[FAULT: Cylinder 3 injection output failure]</i>
Fault Description	Cylinder 3 injection output failure			Fault Lamp	NTO
Fault ID	75	Fault Group	10	Fault Name	<i>[FAULT: Cylinder 4 injection output failure]</i>
Fault Description	Cylinder 4 injection output failure			Fault Lamp	NTO

Fault ID	76	Fault Group	10	Fault Name	<i>[FAULT: Cylinder 5 injection output failure]</i>
Fault Description	Cylinder 5 injection output failure			Fault Lamp	NTO
Fault ID	77	Fault Group	10	Fault Name	<i>[FAULT: Cylinder 6 injection output failure]</i>
Fault Description	Cylinder 6 injection output failure			Fault Lamp	NTO
Fault ID	78	Fault Group	10	Fault Name	<i>[FAULT: Cylinder 7 injection output failure]</i>
Fault Description	Cylinder 7 injection output failure			Fault Lamp	NTO
Fault ID	79	Fault Group	10	Fault Name	<i>[FAULT: Cylinder 8 injection output failure]</i>
Fault Description	Cylinder 8 injection output failure			Fault Lamp	NTO
Root Cause	<p>This fault occurs to indicate inability to actuate the injector as desired due to a circuit fault. The circuit fault may be internal to the ECU (drive stage) or external to the ECU (load or harness).</p> <p>The fault is set under any one of the following conditions:</p> <ul style="list-style-type: none"> - The actuator or the drive stage is Open-circuit - The actuator is short-circuited - Low Side Drive (LSD) is shorted to the GND - High Side Drive (HSD) is shorted to the GND - LSD is shorted to the V Supply - HSD is shorted to the V Supply 				
Troubleshooting Steps for Faults 72 thru 29					
<ol style="list-style-type: none"> 1. Run the engine in accordance with the engine and aircraft maintenance manuals. Is the fault active? If yes or no, continue. Does the behavior of the engine correspond to the fault (missing)? If yes, continue. If no, go to step 3. Are there active faults for other cylinders, or other cylinders behaving the same as the affected cylinder? If yes, go to step 5. If no, go to step 2. 2. Are there faults on both primary and secondary channels for the same injector? If yes, replace the injector. If no, go to step 6. 3. Using the FST, download active and service fault logs. Go to step 4. 4. Review logs to determine which fault was set, and if there are more than one fault. If there are no active faults, but fault(s) keep reoccurring, then if fault is for one injector, go to step 2. If there are faults for multiple injectors, go to step 5. 5. If multiple cylinders and/or channels for multiple injectors were found to be malfunctioning in step 1, or found in step 4, inspect harness for damage (eg...burned, broken or frayed wires, cracked or broken connectors). If damage found, contact Lycoming. If no damage found, replace the ECU. 6. Inspect injector harness connection for any damage (eg...burned, broken or frayed wires, cracked or broken connectors). Contact Lycoming if harness damage is found. If no damage is found, go to step 7. 7. Complete a continuity test of the harness from the harness injector connector to ECU connector A001-P3, and A001-P4, using the engine system schematic. If the continuity check fails, isolate to affected harness by disconnecting the firewall connection, then contact Lycoming Engines. If the continuity check is good, replace the ECU. 					

Fault ID	80	Fault Group	11	Fault Name	<i>[FAULT: Cylinder 1 detonation sensor]</i>						
Fault Description	Cylinder 1 detonation sensor circuit fault			Fault Lamp	TLO						
Fault ID	81	Fault Group	11	Fault Name	<i>[FAULT: Cylinder 2 detonation sensor]</i>						
Fault Description	Cylinder 2 detonation sensor circuit fault			Fault Lamp	TLO						
Fault ID	82	Fault Group	11	Fault Name	<i>[FAULT: Cylinder 3 detonation sensor]</i>						
Fault Description	Cylinder 3 detonation sensor circuit fault			Fault Lamp	TLO						
Fault ID	83	Fault Group	11	Fault Name	<i>[FAULT: Cylinder 4 detonation sensor]</i>						
Fault Description	Cylinder 4 detonation sensor circuit fault			Fault Lamp	TLO						
Fault ID	84	Fault Group	11	Fault Name	<i>[FAULT: Cylinder 5 detonation sensor]</i>						
Fault Description	Cylinder 5 detonation sensor circuit fault			Fault Lamp	TLO						
Fault ID	85	Fault Group	11	Fault Name	<i>[FAULT: Cylinder 6 detonation sensor]</i>						
Fault Description	Cylinder 6 detonation sensor circuit fault			Fault Lamp	TLO						
Fault ID	86	Fault Group	11	Fault Name	<i>[FAULT: Cylinder 7 detonation sensor]</i>						
Fault Description	Cylinder 7 detonation sensor circuit fault			Fault Lamp	TLO						
Fault ID	87	Fault Group	11	Fault Name	<i>[FAULT: Cylinder 8 detonation sensor]</i>						
Fault Description	Cylinder 8 detonation sensor circuit fault			Fault Lamp	TLO						
Root Cause	This fault indicates that the cylinder detonation voltage is consistently outside the minimum and maximum threshold limits inputted in the calibration. The fault will become inactive if the range is within the calibrated range.										
Troubleshooting Steps for Faults 80 thru 87											
1. Is the fault active? If yes, continue. If no, go to step 3. Is there more than one fault? If yes, continue. If no, go to step 2. Are the faults occurring in the combinations shown below? If yes, go to step 5. If no, go to step 2.											
<table border="1" style="margin-left: 40px;"> <tr> <td>Group 1</td> <td>Group 2</td> </tr> <tr> <td>Knock 1 (A016)</td> <td>Knock 2 (A015)</td> </tr> <tr> <td>Knock 3 (A018)</td> <td>Knock 6 (A017)</td> </tr> </table>						Group 1	Group 2	Knock 1 (A016)	Knock 2 (A015)	Knock 3 (A018)	Knock 6 (A017)
Group 1	Group 2										
Knock 1 (A016)	Knock 2 (A015)										
Knock 3 (A018)	Knock 6 (A017)										
2. Check the connector for the following:											
<ul style="list-style-type: none"> a) Harness connector is securely seated to the detonation sensor connector b) No damage to both connectors or cabling. c) Improper/intermittent connection due to loose-fit or vibration d) Improper/Intermittent electrical contact due to debris (such as dust, grease, oil etc.) 											
If a thru d check good, go to step 6.											

Troubleshooting Steps for Faults 80 thru 87 (Cont.)

3. Using the FST, download active and service fault logs.
4. Review logs to determine if the same fault has occurred on other cylinders as shown in the chart above. If yes, go to step 5. If not, go to step 6.
5. If faults occur per Group 1 or Group 2, complete a continuity check using the engine system schematic and the table below. If the continuity check is good, replace the ECU. If the continuity check fails, isolate to affected harness by disconnecting firewall harness, contact Lycoming.

Group 1				ECU Connector	Pin	Sensor Connector	Pin
Connector	Pin	Sensor Connector	Pin	A001-P1	35	A015-P	1
ECU A001-P1	36	A015-P	2		25	A017-P	1
		A017-P	2		26	A019-P	1
Group 2				A001-P2	35	A016-P	1
ECU A001-P2	36	A016-P	2		25	A018-P	1
		A018-P	2		26	A020-P	1

6. Swap detonation sensor with another cylinder. If fault moves with sensor, replace the sensor. If fault does not move with sensor, complete a continuity check of harness from harness knock sensor connector to ECU connector using the engine system schematic. If the continuity check fails, isolate to affected harness by disconnecting firewall harness, contact Lycoming. If the continuity check passes, replace the ECU.

NOTE: If all steps are unsuccessful, contact Lycoming.

Fault ID	88	Fault Group	12	Fault Name	<i>[FAULT: cam sensor]</i>
Fault Description	Cam sensor fault			Fault Lamp	NTO
Root Cause	This fault indicates that a cam synchronization has failed due to an incorrect number of teeth detection or no teeth detection. This fault also indicates an issue with the cam sensor and will be cleared if correct teeth detection resumes				

Troubleshooting Steps

1. Run the engine in accordance with the engine and aircraft maintenance manuals. Is the fault active? If yes, go to step 4. If no, go to step 2.
2. Using the FST, download active and service fault logs. Go to step 3.
3. Review logs to determine if a fault was set. If there are no active faults, but fault keeps reoccurring, then go to step 4.
4. Inspect cam sensor harness connection for any damage (eg...burned, broken or frayed wires, cracked or broken connectors). Contact Lycoming if harness damage is found. If no damage is found, go to step 5.
5. Swap cam sensor with crank sensor. Is the ECU now giving a crank sensor fault? If yes, replace the cam sensor. If no, go to step 6.
6. Complete a continuity test of the harness from the harness cam sensor connector to ECU connector using the engine system schematic. If the continuity check fails, isolate to affected harness by disconnecting the firewall connection, then contact Lycoming Engines. If the continuity check is good, replace the ECU.

Fault ID	89	Fault Group	12	Fault Name	<i>[FAULT: crank sensor]</i>
Fault Description	Crank sensor fault			Fault Lamp	NTO
Root Cause	This fault indicates that a crank synchronization has failed due to an incorrect number of teeth detection or no teeth detection. This fault also indicates an issue with the crank sensor and will be cleared if correct teeth detection resumes				
Troubleshooting Steps					
<ol style="list-style-type: none"> 1. Run the engine in accordance with the engine and aircraft maintenance manuals. Is the fault active? If yes, go to step 4. If no, go to step 2. 2. Using the FST, download active and service fault logs. Go to step 3. 3. Review logs to determine if a fault was set. If there are no active faults, but fault keeps reoccurring, then go to step 4. 4. Inspect crank sensor harness connection for any damage (eg...burned, broken or frayed wires, cracked or broken connectors). Contact Lycoming if harness damage is found. If no damage is found, go to step 5. 5. Swap crank sensor with cam sensor. Is the ECU now giving a cam sensor fault? If yes, replace the crank sensor. If no, go to step 6. 6. Complete a continuity test of the harness from the harness crank sensor connector to ECU connector using the engine system schematic. If the continuity check fails, isolate to affected harness by disconnecting the firewall connection, then contact Lycoming Engines. If the continuity check is good, replace the ECU. 					

Fault ID	90	Fault Group	12	Fault Name	<i>[FAULT: wastegate output failure]</i>
Fault Description	Waste Gate output driver fault			Fault Lamp	NTO
Root Cause	<p>This fault occurs to indicate inability to actuate the Wastegate as desired due to a circuit fault. The circuit fault may be internal to the ECU (drive stage) or external to the ECU (load or harness).</p> <p>The fault is set under any one of the following conditions:</p> <ul style="list-style-type: none"> - The actuator or the drive stage is Open-circuit - The actuator is short-circuited - Low Side Drive (LSD) is shorted to the GND - High Side Drive (HSD) is shorted to the GND - LSD is shorted to the V Supply - HSD is shorted to the V Supply 				
Troubleshooting Steps					
<ol style="list-style-type: none"> 1. Run the engine in accordance with the engine and aircraft maintenance manuals. Is the fault active? If yes, go to step 2. If no, go to step 3. 2. Are there faults on both primary and secondary channels for the waste gate actuator? If yes, go to step 5. If no, go to step 6. 3. Using the FST, download active and service fault logs. Go to step 4. 4. Review logs to determine which fault was set, and if there are more than one fault. If there are no active faults, but fault(s) keep reoccurring, go to step 5. 5. If faults are found on both channels, inspect harness for damage (eg...burned, broken or frayed wires, cracked or broken connectors). If damage found, contact Lycoming. If no damage found, replace the waste gate actuator. 6. Inspect waste gate actuator harness connection for any damage (eg...burned, broken or frayed wires, cracked or broken connectors). Contact Lycoming if harness damage is found. If no damage is found, go to step 7. 7. Complete a continuity test of the harness from the harness injector connector to ECU connector A001-P3, and A001-P4, using the engine system schematic. If the continuity check fails, isolate to affected harness by disconnecting the firewall connection, then contact Lycoming Engines. If the continuity check is good, replace the ECU. 					

Fault ID	91	Fault Group	12	Fault Name	<i>[FAULT: prop-pitch output failure]</i>
Fault Description	Prop-pitch output driver fault			Fault Lamp	NTO
Root Cause	This fault occurs to indicate inability to control the Propeller Pitch actuator as desired due to a circuit fault. The circuit fault may be internal to the ECU (drive stage) or external to the ECU (load or harness). The fault is set under any one of the following conditions: <ul style="list-style-type: none"> - The actuator or the drive stage is Open-circuit - The actuator is short-circuited - Low Side Drive (LSD) is shorted to the GND - High Side Drive (HSD) is shorted to the GND - LSD is shorted to the V Supply - HSD is shorted to the V Supply 				
Troubleshooting Steps					
1. Run the engine in accordance with the engine and aircraft maintenance manuals. Is the fault active? If yes, go to step 2. If no, go to step 3. 2. Are there faults on both primary and secondary channels for the propeller governor? If yes, go to step 5. If no, go to step 6. 3. Using the FST, download active and service fault logs. Go to step 4. 4. Review logs to determine which fault was set, and if there are more than one fault. If there are no active faults, but fault(s) keep reoccurring, go to step 5. 5. If faults are found on both channels, inspect harness for damage (eg...burned, broken or frayed wires, cracked or broken connectors). If damage found, contact Lycoming. If no damage found, replace the propeller governor. 6. Inspect propeller governor harness connection for any damage (eg...burned, broken or frayed wires, cracked or broken connectors). Contact Lycoming if harness damage is found. If no damage is found, go to step 7. 7. Complete a continuity test of the harness from the harness injector connector to ECU connector A001-P3, and A001-P4, using the engine system schematic. If the continuity check fails, isolate to affected harness by disconnecting the firewall connection, then contact Lycoming Engines. If the continuity check is good, replace the ECU.					

Fault ID	92	Fault Group	12	Fault Name	<i>-reserved-</i>
Fault Description				Fault Lamp	NTO
Root Cause					
Troubleshooting Steps					

Fault ID	93	Fault Group	12	Fault Name	<i>-reserved-</i>
Fault Description				Fault Lamp	NTO
Root Cause					
Troubleshooting Steps					

Fault ID	94	Fault Group	12	Fault Name	<i>-reserved-</i>
Fault Description				Fault Lamp	NTO
Root Cause					
Troubleshooting Steps					

Fault ID	95	Fault Group	12	Fault Name	<i>-reserved-</i>
Fault Description				Fault Lamp	NTO
Root Cause					
Troubleshooting Steps					

Fault ID	96	Fault Group	13	Fault Name	<i>[FAULT: local takeoff reserve switch stuck]</i>
Fault Description	Local Take off reserve switch stuck fault			Fault Lamp	FFL
Root Cause	This fault indicates digital input local take-off switch is stuck "ON" possibly due to a switch hardware issue. The fault will become inactive is the switch toggles to "OFF" position				
Troubleshooting Steps					
<ol style="list-style-type: none"> 1. Disconnect wires from switch. Does fault go inactive? If yes, replace the switch. If no, go to step 2. 2. Complete a continuity and short circuit test of the harness from the switch connector(s) to ECU connectors using the engine system schematic. If the continuity or short circuit check fails, isolate to affected harness by disconnecting the airframe interface connection AF-P1. If problem is isolated to engine airframe harness, contact Lycoming Engines. If problem is found from switch to AF-J1, repair in accordance with aircraft maintenance manual. If the continuity check is good, replace the ECU. 					

Fault ID	97	Fault Group	13	Fault Name	<i>[FAULT: local takeoff reserve switch noise]</i>
Fault Description	Local Take off reserve switch noise fault			Fault Lamp	FFL
Root Cause	This fault indicates local take-off switch is noisy. The fault will become inactive if the noise is reduced.				
Troubleshooting Steps					
<ol style="list-style-type: none"> 1. Disconnect wires from switch. Does fault go inactive? If yes, replace the switch. If no, go to step 2. 2. Complete a continuity and short circuit test of the harness from the switch connector(s) to ECU connectors using the engine system schematic. If the continuity or short circuit check fails, isolate to affected harness by disconnecting the airframe interface connection AF-P1. If problem is isolated to engine airframe harness, contact Lycoming Engines. If problem is found from switch to AF-J1, repair in accordance with aircraft maintenance manual. If the continuity check is good, replace the ECU. 					

Fault ID	98	Fault Group	13	Fault Name	<i>[FAULT: takeoff reserve time discrepancy]</i>
Fault Description	Take off reserve time discrepancy fault			Fault Lamp	FFL
Root Cause	This fault indicates the primary and secondary channel's take off reserve time differ by more than the calibrated maximum discrepancy possibly due to one channel down while the other channel was operational.				
Troubleshooting Steps					
NOTE: The ECU has to be hard reset at the facility for the fault to be inactive or the discrepancy limit needs to be below the maximum calibrated limit. This fault doesn't cause any operational or performance risks hence is considered very low risk.					

Fault ID	99	Fault Group	13	Fault Name	<i>[FAULT: takeoff reserve time invalid]</i>
Fault Description	Take off reserve time invalid fault			Fault Lamp	FFL
Root Cause	This fault indicates the primary and secondary channel's take off reserve time is invalid possibly due to a NVM (Non-Volatile Memory) issue				
Troubleshooting Steps					
NOTE: The ECU has to be hard reset at the facility for the fault to be inactive. This fault doesn't cause any operational or performance risks hence is considered very low risk.					

Fault ID	100	Fault Group	13	Fault Name	<i>[FAULT: takeoff reserve switch discrepancy]</i>
Fault Description	Take off reserve switch discrepancy fault			Fault Lamp	FFL
Root Cause	This fault indicates the primary and secondary channel's take off reserve switch position differ possibility due to a switch hardware issue. The fault will become inactive if one of both switch change position and agree with each other.				
Troubleshooting Steps					
<ol style="list-style-type: none"> 1. Disconnect wires from switch. Does fault go inactive? If yes, replace the switch. If no, go to step 2. 2. Complete a continuity and short circuit test of the harness from the switch connector(s) to ECU connectors using the engine system schematic. If the continuity or short circuit check fails, isolate to affected harness by disconnecting the airframe interface connection AF-P1. If problem is isolated to engine airframe harness, contact Lycoming Engines. If problem is found from switch to AF-J1, repair in accordance with aircraft maintenance manual. If the continuity check is good, replace the ECU. 					

Fault ID	101	Fault Group	13	Fault Name	<i>[FAULT: digital channel ID discrepancy]</i>
Fault Description	Digital Channel ID discrepancy fault			Fault Lamp	FFL
Root Cause	This fault indicates the primary and secondary channel ID are identical OR channel ID is invalid on at least one of the two channels possibly due to memory corruption or GPIO (General Purpose Input Output) issue				
Troubleshooting Steps					
<ol style="list-style-type: none"> 1. Contact Lycoming Personnel to have the ECU reprogrammed with appropriate boot and application code to ensure the fault has become inactive* 2. If step 1 is unsuccessful, contact Lycoming to have ECU replaced. 					

Fault ID	102	Fault Group	13	Fault Name	<i>-Reserved-</i>
Fault Description				Fault Lamp	FFL
Root Cause					
Troubleshooting Steps					

Fault ID	103	Fault Group	13	Fault Name	<i>-Reserved-</i>
Fault Description				Fault Lamp	FFL
Root Cause					
Troubleshooting Steps					

Fault ID	104	Fault Group	14	Fault Name	<i>[FAULT: local pre-flight test switch noise]</i>
Fault Description	Local pre-flight test switch noise fault			Fault Lamp	FFL
Root Cause	This fault indicates the primary and secondary channel ID are identical OR channel ID is invalid on at least one of the two channel possibly due to memory corruption or GPIO (General Purpose Input Output) issue.				
Troubleshooting Steps					
<ol style="list-style-type: none"> 1. Disconnect wires from switch. Does fault go inactive? If yes, replace the switch. If no, go to step 2. 2. Complete a continuity and short circuit test of the harness from the switch connector(s) to ECU connectors using the engine system schematic. If the continuity or short circuit check fails, isolate to affected harness by disconnecting the airframe interface connection AF-P1. If problem is isolated to engine airframe harness, contact Lycoming Engines. If problem is found from switch to AF-J1, repair in accordance with aircraft maintenance manual. If the continuity check is good, replace the ECU. 					

Fault ID	105	Fault Group	14	Fault Name	<i>[FAULT: local pre-flight test switch stuck]</i>
Fault Description	Local pre-flight test switch stuck fault			Fault Lamp	FFL
Root Cause	This fault indicates the digital input local pre-flight test switch is stuck on possibly due to a switch hardware issue. The fault will become inactive if the switch toggles to off position				
Troubleshooting Steps					
<ol style="list-style-type: none"> 1. Disconnect wires from switch. Does fault go inactive? If yes, replace the switch. If no, go to step 2. 2. Complete a continuity and short circuit test of the harness from the switch connector(s) to ECU connectors using the engine system schematic. If the continuity or short circuit check fails, isolate to affected harness by disconnecting the airframe interface connection AF-P1. If problem is isolated to engine airframe harness, contact Lycoming Engines. If problem is found from switch to AF-J1, repair in accordance with aircraft maintenance manual. If the continuity check is good, replace the ECU. 					

Fault ID	106	Fault Group	14	Fault Name	<i>[FAULT: PFT out of sequence]</i>
Fault Description	PFT out of sequence			Fault Lamp	FFL
Root Cause	This fault indicates that the PFT test state is not at the correct state based on an internal timer possibly due to a failed test case or timed out during PFT. The fault will be cleared once the PFT passes.				
Troubleshooting Steps					
<ol style="list-style-type: none"> 1. If PFT failed, push PFT switch again to acknowledge a failed test and reset the PFT state 2. Initiate PFT using the PFT switch and ensure PFT pass condition is achieved 3. If PFT failed twice in a row, contact Lycoming for further troubleshooting guidance. 					

Fault ID	107	Fault Group	14	Fault Name	<i>[FAULT: pre-flight test switch discrepancy]</i>
Fault Description	PFT test switch discrepancy fault			Fault Lamp	FFL
Root Cause	This fault indicates that the primary and secondary channel's pre-flight test switch differ possibly due to a hardware switch issue. The fault will become inactive if both test switches change and agree with each other.				
Troubleshooting Steps					
<ol style="list-style-type: none"> 1. Disconnect wires from switch. Does fault go inactive? If yes, replace the switch. If no, go to step 2. 2. Complete a continuity and short circuit test of the harness from the switch connector(s) to ECU connectors using the engine system schematic. If the continuity or short circuit check fails, isolate to affected harness by disconnecting the airframe interface connection AF-P1. If problem is isolated to engine airframe harness, contact Lycoming Engines. If problem is found from switch to AF-J1, repair in accordance with aircraft maintenance manual. If the continuity check is good, replace the ECU. 					

Fault ID	108	Fault Group	14	Fault Name	<i>-Reserved-</i>
Fault Description				Fault Lamp	FFL
Root Cause					
Troubleshooting Steps					

Fault ID	109	Fault Group	14	Fault Name	<i>-Reserved-</i>
Fault Description				Fault Lamp	FFL
Root Cause					
Troubleshooting Steps					

Fault ID	110	Fault Group	14	Fault Name	<i>-Reserved-</i>
Fault Description				Fault Lamp	FFL
Root Cause					
Troubleshooting Steps					

Fault ID	111	Fault Group	14	Fault Name	<i>-Reserved-</i>
Fault Description				Fault Lamp	FFL
Root Cause					
Troubleshooting Steps					
Fault ID	112	Fault Group	15	Fault Name	<i>[FAULT: CAN 1 Initialization Failure]</i>
Fault Description	CAN 1 initialization fault			Fault Lamp	None
Root Cause	This fault indicates that communication has failed to initialize on CAN (Controller Area Network) 1				
Troubleshooting Steps					
<ol style="list-style-type: none"> 1. With Ignition switch in OFF position, remove ECU power by pulling the ECU circuit breaker. Wait 10s before resetting. 2. Apply power to ECU. Is fault still active? If yes, replace the ECU. If no, go to step 3 3. Clear service faults using the FST. 					
Fault ID	113	Fault Group	15	Fault Name	<i>[FAULT: CAN 2 Initialization Failure]</i>
Fault Description	CAN 2 initialization fault			Fault Lamp	None
Root Cause	This fault indicates that communication has failed to initialize on CAN 2				
Troubleshooting Steps					
<ol style="list-style-type: none"> 1. With Ignition switch in OFF position, remove ECU power by pulling the ECU circuit breaker. Wait 10s before resetting. 2. Apply power to ECU. Is fault still active? If yes, replace the ECU. If no, go to step 3 3. Using the FST, download active and service fault logs, then clear fault logs and monitor engine operation for the fault to repeat. 					
Fault ID	114	Fault Group	15	Fault Name	<i>[FAULT: CAN 3 Initialization Failure]</i>
Fault Description	CAN 3 initialization fault			Fault Lamp	None
Root Cause	This fault indicates that communication has failed to initialize on CAN 3				
Troubleshooting Steps					
<ol style="list-style-type: none"> 1. With Ignition switch in OFF position, remove ECU power by pulling the ECU circuit breaker. Wait 10s before resetting. 2. Apply power to ECU. Is fault still active? If yes, replace the ECU. If no, go to step 3 3. Using the FST, download active and service fault logs, then clear fault logs and monitor engine operation for the fault to repeat. 					
Fault ID	115	Fault Group	15	Fault Name	<i>[FAULT: CAN1 Error]</i>
Fault Description	CAN 1 error fault			Fault Lamp	None
Root Cause	This fault indicates a hardware error detected in CAN 1 device				
Troubleshooting Steps					
<ol style="list-style-type: none"> 1. With Ignition switch in OFF position, remove ECU power by pulling the ECU circuit breaker. Wait 10s before resetting. 2. Apply power to ECU. Is fault still active? If yes, replace the ECU. If no, go to step 3 3. Clear service faults using the FST. Does the fault reoccur? If yes, replace the ECU. 					

Fault ID	116	Fault Group	15	Fault Name	<i>[FAULT: CAN2 Error]</i>
Fault Description	CAN 2 error fault			Fault Lamp	None
Root Cause	This fault indicates a hardware error detected in CAN 2 device				
Troubleshooting Steps					
<ol style="list-style-type: none"> 1. Is the fault intermittent? If yes, see note. If no, go to step 2. 2. With ignition switch in OFF position, remove ECU power by pulling the ECU circuit breaker. Wait 10s before resetting. Is fault still active? If yes, go to step 3. 3. Disconnect each hardware item connected to the CAN bus, one at a time (ie. Data logger...etc.). Is fault still active? If yes, go to step 4. If no, replace the hardware item that caused the fault. 4. Complete a continuity and short circuit test of the harness from the aircraft CAN interface connector to ECU connectors using the engine system schematic and aircraft wiring diagram. If the continuity or short circuit check fails, isolate to affected harness by disconnecting the airframe interface connection AF-P1. If problem is isolated to engine airframe harness, contact Lycoming Engines. If problem is found from CAN interface connector to AF-J1, repair in accordance with aircraft maintenance manual. If the continuity check is good, replace the ECU. <p>NOTE: If this fault is intermittent, it is due to too much data being requested from the ECU than the controller can provide through CAN 2. This fault, if it is intermittent, does not affect the operation or performance of the system, and is considered low risk.</p>					

Fault ID	117	Fault Group	15	Fault Name	<i>[FAULT: CAN3 Error]</i>
Fault Description	CAN 3 error fault			Fault Lamp	None
Root Cause	This fault indicates a hardware error detected in CAN 3 device				
Troubleshooting Steps					
<ol style="list-style-type: none"> 1. Is the fault intermittent? If yes, see note. If no, go to step 2. 2. With Ignition switch in OFF position, remove ECU power by pulling the ECU circuit breaker. Wait 10s before resetting. Is fault still active? If yes, go to step 3. 3. Disconnect each hardware item connected to the CAN bus, one at a time (ie. Engine instrument display...etc.). Is fault still active? If yes, go to step 4. If no, replace the hardware item that caused the fault. 4. Disconnect connector(s) from aircraft engine instrumentation display. Did fault go inactive? If yes, isolate fault in engine instrumentation display system. If no, go to step 5. 5. Complete a continuity and short circuit test of the harness from the aircraft engine instrument display connector to ECU connector using the engine system schematic and aircraft wiring diagram. If the continuity or short circuit check fails, isolate to affected harness by disconnecting the airframe interface connection AF-P1. If problem is isolated to engine airframe harness, contact Lycoming Engines. If problem is found from aircraft engine instrument display connector to AF-J1, repair in accordance with aircraft maintenance manual. If the continuity check is good, using aircraft maintenance manual, and serviceability of the aircraft engine instrument display has been verified, replace the ECU. <p>NOTE: If this fault is intermittent, it is due to too much data being requested from the ECU than the controller can provide through CAN 3. This fault, if it is intermittent, does not affect the operation or performance of the system, and is considered low risk.</p>					

Fault ID	118	Fault Group	15	Fault Name	<i>[FAULT: CCP message watchdog]</i>
Fault Description	CAN configuration Protocol message watchdog fault			Fault Lamp	None
Root Cause	This fault indicates a communication failure of CAN configuration protocol interface. The fault will become inactive communication resumes				
Troubleshooting Steps					
<ol style="list-style-type: none"> 1. Is the fault intermittent? If yes, see note. If no, go to step 2. 2. With Ignition switch in OFF position, remove ECU power by pulling the ECU circuit breaker. Wait 10s before resetting. Is fault still active? If no, go to step 3. If yes, replace the ECU, then go to step 3. 3. Using the FST, download active and service fault logs, then clear fault logs and monitor engine operation for the fault to repeat. <p>*NOTE: This fault can be caused by too much data being requested from the ECU than the controller can provide through CAN 2 and CAN 3. This fault doesn't cause any operational or performance issues and is considered low risk.</p>					

Fault ID	119	Fault Group	15	Fault Name	<i>-Reserved-</i>
Fault Description				Fault Lamp	
Root Cause					
Troubleshooting Steps					

Fault ID	120	Fault Group	16	Fault Name	<i>[FAULT: channel ID discrepancy]</i>
Fault Description	Channel Identifier Discrepancy Fault			Fault Lamp	NTO
Root Cause	This fault indicates that ECU channel ID was conflicted between the GPIO (General Purpose Input Output) channel ID pin, Unit Factory Calibration and the Application Software program version possibly due a wrong software load, corrupted memory and or hardware issues.				
Troubleshooting Steps					
<ol style="list-style-type: none"> 1. Contact Lycoming Personnel to have the ECU reprogrammed. 2. Clear service fault codes. Start the engine. Is the fault still active? If yes, replace the ECU. 					

Fault ID	121	Fault Group	16	Fault Name	<i>-Reserved-</i>
Fault Description				Fault Lamp	NTO
Root Cause					
Troubleshooting Steps					

Fault ID	122	Fault Group	16	Fault Name	<i>[FAULT: local channel Id]</i>
Fault Description	Local Channel Identifier Fault			Fault Lamp	NTO
Root Cause	This fault indicates the GPIO pin changed values during application execution possibly due to a hardware issue or memory corruption				
Troubleshooting Steps					
1. Contact Lycoming Personnel to have the ECU reprogrammed. 2. Clear service fault codes. Start the engine. Is the fault still active? If yes, replace the ECU.					

Fault ID	123	Fault Group	16	Fault Name	<i>[FAULT: Unit serial number invalid]</i>
Fault Description	Local Channel Identifier Fault			Fault Lamp	NTO
Root Cause	This fault indicates Unit Factory Calibration area is corrupt OR the unit serial number in the Unit Factory Calibration area has maxed out on the greatest number possible due to a possible hardware issue. The fault may be inactive upon reprogramming the unit				
Troubleshooting Steps					
1. Contact Lycoming Personnel to have the ECU reprogrammed. 2. Clear service fault codes. Start the engine. Is the fault still active? If yes, replace the ECU.					

Fault ID	124	Fault Group	16	Fault Name	<i>-Reserved-</i>
Fault Description				Fault Lamp	NTO
Root Cause					
Troubleshooting Steps					

Fault ID	125	Fault Group	16	Fault Name	<i>-Reserved-</i>
Fault Description				Fault Lamp	NTO
Root Cause					
Troubleshooting Steps					

Fault ID	126	Fault Group	16	Fault Name	<i>-Reserved-</i>
Fault Description				Fault Lamp	NTO
Root Cause					
Troubleshooting Steps					

Fault ID	127	Fault Group	16	Fault Name	<i>-Reserved-</i>
Fault Description				Fault Lamp	NTO
Root Cause					
Troubleshooting Steps					

Fault ID	128	Fault Group	17	Fault Name	<i>[FAULT: cylinder head temperature cyl 1 slew rate]</i>
Fault Description	Cylinder head temperature 1 slew rate fault			Fault Lamp	None
Fault ID	129	Fault Group	17	Fault Name	<i>[FAULT: cylinder head temperature cyl 2 slew rate]</i>
Fault Description	Cylinder head temperature 2 slew rate fault			Fault Lamp	None
Fault ID	130	Fault Group	17	Fault Name	<i>[FAULT: cylinder head temperature cyl 3 slew rate]</i>
Fault Description	Cylinder head temperature 3 slew rate fault			Fault Lamp	None
Fault ID	131	Fault Group	17	Fault Name	<i>[FAULT: cylinder head temperature cyl 4 slew rate]</i>
Fault Description	Cylinder head temperature 4 slew rate fault			Fault Lamp	None
Fault ID	132	Fault Group	17	Fault Name	<i>[FAULT: cylinder head temperature cyl 5 slew rate]</i>
Fault Description	Cylinder head temperature 5 slew rate fault			Fault Lamp	None
Fault ID	133	Fault Group	17	Fault Name	<i>[FAULT: cylinder head temperature cyl 6 slew rate]</i>
Fault Description	Cylinder head temperature 6 slew rate fault			Fault Lamp	None
Fault ID	134	Fault Group	17	Fault Name	<i>[FAULT: cylinder head temperature cyl 7 slew rate]</i>
Fault Description	Cylinder head temperature 7 slew rate fault			Fault Lamp	None
Fault ID	135	Fault Group	17	Fault Name	<i>[FAULT: cylinder head temperature cyl 8 slew rate]</i>
Fault Description	Cylinder head temperature 8 slew rate fault			Fault Lamp	None
Root Cause	This fault indicates the temperature sensor slew rate is greater than the calibrated maximum.				
Troubleshooting Steps for Faults 128 thru 135					
<ol style="list-style-type: none"> 1. Run the engine in accordance with the engine and aircraft maintenance manuals. Is the fault active? * If yes, go to step 3. If no, go to step 2. 2. Using the FST, download active and service fault logs, then clear fault logs and monitor engine operation for the fault to repeat. 3. Swap the sensor from the channel giving the fault with another sensor in a different cylinder, and run the engine. Did the fault move with the sensor? If yes, replace the sensor per the “Sensor Replacement Procedures” section in Chapter 72-70. If no, complete a continuity test of the harness from the harness sensor connector to the ECU connector using the engine system schematic. If the continuity check fails, isolate to affected harness by disconnecting the firewall connection, then contact Lycoming Engines. If the continuity checks good, replace the ECU. <p>*NOTE: This fault could be caused by another CHT fault. If there are any other active CHT faults on the same cylinder go to troubleshooting steps for the corresponding CHT fault.</p>					

Fault ID	136	Fault Group	18	Fault Name	<i>[FAULT: exhaust gas temperature cyl 1 slew rate]</i>
Fault Description	Exhaust Gas Temperature cyl 1 slew rate fault			Fault Lamp	None
Fault ID	137	Fault Group	18	Fault Name	<i>[FAULT: exhaust gas temperature cyl 2 slew rate]</i>
Fault Description	Exhaust Gas Temperature cyl 2 slew rate fault			Fault Lamp	None
Fault ID	138	Fault Group	18	Fault Name	<i>[FAULT: exhaust gas temperature cyl 3 slew rate]</i>
Fault Description	Exhaust Gas Temperature cyl 3 slew rate fault			Fault Lamp	None
Fault ID	139	Fault Group	18	Fault Name	<i>[FAULT: exhaust gas temperature cyl 4 slew rate]</i>
Fault Description	Exhaust Gas Temperature cyl 4 slew rate fault			Fault Lamp	None
Fault ID	140	Fault Group	18	Fault Name	<i>[FAULT: exhaust gas temperature cyl 5 slew rate]</i>
Fault Description	Exhaust Gas Temperature cyl 5 slew rate fault			Fault Lamp	None
Fault ID	141	Fault Group	18	Fault Name	<i>[FAULT: exhaust gas temperature cyl 6 slew rate]</i>
Fault Description	Exhaust Gas Temperature cyl 6 slew rate fault			Fault Lamp	None
Fault ID	142	Fault Group	18	Fault Name	<i>[FAULT: exhaust gas temperature cyl 7 slew rate]</i>
Fault Description	Exhaust Gas Temperature cyl 7 slew rate fault			Fault Lamp	None
Fault ID	143	Fault Group	18	Fault Name	<i>[FAULT: exhaust gas temperature cyl 8 slew rate]</i>
Fault Description	Exhaust Gas Temperature cyl 8 slew rate fault			Fault Lamp	None
Root Cause	This fault indicates the temperature sensor slew rate is greater than the calibrated maximum.				
Troubleshooting Steps for Faults 136 thru 143					
<ol style="list-style-type: none"> 1. Run the engine in accordance with the engine and aircraft maintenance manuals. Is the fault active? * If yes, go to step 3. If no, go to step 2. 2. Using the FST, download active and service fault logs, then clear fault logs and monitor engine operation for the fault to repeat. 3. Swap the sensor from the channel giving the fault with another sensor in a different cylinder and run the engine. Did the fault move with the sensor? If yes, replace the sensor per the "Sensor Replacement Procedures" section in Chapter 72-70. If no, complete a continuity test of the harness from the harness sensor connector to the ECU connector using the engine system schematic. If the continuity check fails, isolate to affected harness by disconnecting the firewall connection, then contact Lycoming Engines. If the continuity checks good, replace the ECU. <p>*NOTE: This fault could be caused by another EGT fault. If there are any other active EGT faults on the same cylinder go to troubleshooting steps for the corresponding EGT fault.</p>					

Fault ID	144	Fault Group	19	Fault Name	<i>[FAULT: turbine inlet temperature 1 slew rate]</i>
Fault Description	Turbine Inlet Temperature 1 Slew rate			Fault Lamp	None
Fault ID	145	Fault Group	19	Fault Name	<i>[FAULT: turbine inlet temperature 2 slew rate]</i>
Fault Description	Turbine Inlet Temperature 2 Slew rate			Fault Lamp	None
Root Cause	This fault indicates the temperature sensor slew rate is greater than the calibrated maximum.				
Troubleshooting Steps for Faults 144 and 145					
<ol style="list-style-type: none"> 1. Run the engine in accordance with the engine and aircraft maintenance manuals. Is the fault active? * If yes, go to step 3. If no, go to step 2. 2. Using the FST, download active and service fault logs, then clear fault logs and monitor engine operation for the fault to repeat. 3. Inspect TIT sensor, and lead for any damage (eg...burned, broken or frayed wires, cracked or broken connectors, burned or broken sensors). Replace any damaged sensors per the “Sensor Replacement Procedures” section in Chapter 72-70. If no damage is found, go to step 4. 4. Inspect TIT harness connection for any damage (eg...burned, broken or frayed wires, cracked or broken connectors). Contact Lycoming if harness damage is found. If no damage found, go to step 5. 5. Complete a continuity test of the harness from the harness sensor connector to the ECU connector using the engine system schematic. If the continuity check fails, isolate to affected harness by disconnecting the firewall connection, then contact Lycoming Engines. If the continuity checks good, replace the sensor. If fault persists, replace the ECU. <p>*NOTE: This fault could be caused by another TIT fault. If there are any other active TIT faults, go to troubleshooting steps for the corresponding TIT fault.</p>					

Fault ID	146	Fault Group	19	Fault Name	<i>[FAULT: local manifold temperature slew rate]</i>
Fault Description	Local Manifold temperature slew rate fault			Fault Lamp	None
Root Cause	This fault indicates the temperature sensor slew rate is greater than the calibrated maximum.				
Troubleshooting Steps					
<ol style="list-style-type: none"> 1. Run the engine in accordance with the engine and aircraft maintenance manuals. Is the fault active? * If yes, go to step 3. If no, go to step 2. 2. Using the FST, download active and service fault logs, then clear fault logs and monitor engine operation for the fault to repeat. 3. Swap the sensor giving the fault with opposite sensor and run the engine. Did the fault move with the sensor? If yes, replace the sensor per the “Sensor Replacement Procedures” section in Chapter 72-70. If no, complete a continuity test of the harness from the harness sensor connector to the ECU connector using the engine system schematic. If the continuity check fails, isolate to affected harness by disconnecting the firewall connection, then contact Lycoming Engines. If the continuity checks good, replace the ECU. <p>*NOTE: This fault could be caused by another manifold air temperature fault. If there are any other active manifold air temperature faults go to troubleshooting steps for the corresponding manifold air temperature fault.</p>					

Fault ID	147	Fault Group	19	Fault Name	<i>[FAULT: deck temperature slew rate]</i>
Fault Description	Deck Temperature slew rate fault			Fault Lamp	None
Root Cause	This fault indicates the temperature sensor slew rate is greater than the calibrated maximum.				
Troubleshooting Steps					
<ol style="list-style-type: none"> 1. Run the engine in accordance with the engine and aircraft maintenance manuals. Is the fault active? * If yes, go to step 3. If no, go to step 2. 2. Using the FST, download active and service fault logs, then clear fault logs and monitor engine operation for the fault to repeat. 3. Swap the sensor giving the fault with one of the MAT sensors (A035, or A042), and run the engine. Is there now an active manifold air temperature slew rate fault? If yes, replace the sensor per the “Sensor Replacement Procedures” section in Chapter 72-70. If no, complete a continuity test of the harness from the harness sensor connector to the ECU connector using the engine system schematic. If the continuity check fails, isolate to affected harness by disconnecting the firewall connection, then contact Lycoming Engines. If the continuity checks good, replace the ECU. <p>*NOTE: This fault could be caused by another deck temperature fault. If there are any other active deck temperature faults, go to troubleshooting steps for the corresponding deck temperature fault.</p>					

Fault ID	148	Fault Group	19	Fault Name	<i>[FAULT: fuel rail temperature slew rate]</i>
Fault Description	Fuel rail temperature slew rate fault			Fault Lamp	None
Root Cause	This fault indicates the temperature sensor slew rate is greater than the calibrated maximum.				
Troubleshooting Steps					
<ol style="list-style-type: none"> 1. Run the engine in accordance with the engine and aircraft maintenance manuals. Is the fault active? * If yes, go to step 3. If no, go to step 2. 2. Using the FST, download active and service fault logs, then clear fault logs and monitor engine operation for the fault to repeat. 3. Swap the fuel rail temp sensor with the oil temperature sensor (A026) and run the engine. Is there now an active oil temperature slew rate fault? If yes, replace the sensor per the “Sensor Replacement Procedures” section in Chapter 72-70. If no, complete a continuity test of the harness from the harness sensor connector to the ECU connector using the engine system schematic. If the continuity check fails, isolate to affected harness by disconnecting the firewall connection, then contact Lycoming Engines. If the continuity checks good, replace the ECU. <p>*NOTE: This fault could be caused by another fuel temperature fault. If there are any other active fuel temperature faults go to troubleshooting steps for the corresponding fuel temperature fault.</p>					

Fault ID	149	Fault Group	19	Fault Name	<i>[FAULT: engine oil temperature slew rate]</i>
Fault Description	Engine Oil temperature slew rate fault		Fault Lamp	None	
Root Cause	This fault indicates the temperature sensor slew rate is greater than the calibrated maximum.				
Troubleshooting Steps					
<ol style="list-style-type: none"> 1. Run the engine in accordance with the engine and aircraft maintenance manuals. Is the fault active? * If yes, go to step 3. If no, go to step 2. 2. Using the FST, download active and service fault logs, then clear fault logs and monitor engine operation for the fault to repeat. 3. Swap the oil temperature sensor with the fuel rail temp sensor (A012) and run the engine. Is there now an active fuel rail temp slew rate fault? If yes, replace the sensor per the “Sensor Replacement Procedures” section in Chapter 72-70. If no, complete a continuity test of the harness from the harness sensor connector to the ECU connector using the engine system schematic. If the continuity check fails, isolate to affected harness by disconnecting the firewall connection, then contact Lycoming Engines. If the continuity checks good, replace the ECU. <p>*NOTE: This fault could be caused by another oil temperature fault. If there are any other active oil temperature faults go to troubleshooting steps for the corresponding oil temperature fault.</p>					

Fault ID	150	Fault Group	19	Fault Name	<i>[FAULT: venturi pressure slew rate]</i>
Fault Description	Venturi Pressure slew rate fault		Fault Lamp	None	
Root Cause	This fault indicates the pressure sensor slew rate is greater than the calibrated maximum.				
Troubleshooting Steps					
<ol style="list-style-type: none"> 1. Run the engine in accordance with the engine and aircraft maintenance manuals. Is the fault active? * If yes, go to step 3. If no, go to step 2. 2. Using the FST, download active and service fault logs, then clear fault logs and monitor engine operation for the fault to repeat. 3. Inspect sensor, and lead for any damage (eg...burned, broken or frayed wires, cracked or broken connectors, burned or broken sensors). If damaged, replace the sensor per the “Sensor Replacement Procedures” section in Chapter 72-70. If no damage is found, go to step 4. 4. Inspect harness connection for any damage (eg...burned, broken or frayed wires, cracked or broken connectors). Contact Lycoming if harness damage is found. If no damage found, go to step 5. 5. Complete a continuity test of the harness from the harness sensor connector to the ECU connector using the engine system schematic. If the continuity check fails, isolate to affected harness by disconnecting the firewall connection, then contact Lycoming Engines. If the continuity checks good, replace the sensor. If fault persists, replace the ECU. <p>*NOTE: This fault could be caused by another venturi pressure fault. If there are any other active venturi pressure faults go to troubleshooting steps for the corresponding venturi pressure fault.</p>					

Fault ID	151	Fault Group	19	Fault Name	<i>[FAULT: manifold pressure slew rate]</i>
Fault Description	Manifold Pressure slew rate fault			Fault Lamp	None
Root Cause	This fault indicates the pressure sensor slew rate is greater than the calibrated maximum.				
Troubleshooting Steps					
<ol style="list-style-type: none"> 1. Run the engine in accordance with the engine and aircraft maintenance manuals. Is the fault active? * If yes, go to step 3. If no, go to step 2. 2. Using the FST, download active and service fault logs, then clear fault logs and monitor engine operation for the fault to repeat. 3. Inspect sensor, and lines for any damage (eg...burned, broken or frayed wires, cracked or broken connectors or hoses, burned or broken sensors). If damaged, replace the sensor per the “Sensor Replacement Procedures” section in Chapter 72-70. If no damage is found, go to step 4. 4. Inspect harness connection for any damage (eg...burned, broken or frayed wires, cracked or broken connectors). Contact Lycoming if harness damage is found. If no damage found, go to step 5. 5. Complete a continuity test of the harness from the harness sensor connector to the ECU connector using the engine system schematic. If the continuity check fails, isolate to affected harness by disconnecting the firewall connection, then contact Lycoming Engines. If the continuity checks good, replace the sensor. If fault persists, replace the ECU. <p>*NOTE: This fault could be caused by another manifold pressure fault. If there are any other active manifold pressure faults go to troubleshooting steps for the corresponding manifold pressure fault.</p>					

Fault ID	152	Fault Group	20	Fault Name	<i>[FAULT: local deck pressure slew rate]</i>
Fault Description	Local Deck Pressure slew rate fault			Fault Lamp	None
Root Cause	This fault indicates the pressure sensor slew rate is greater than the calibrated maximum.				
Troubleshooting Steps					
<ol style="list-style-type: none"> 1. Run the engine in accordance with the engine and aircraft maintenance manuals. Is the fault active? * If yes, go to step 3. If no, go to step 2. 2. Using the FST, download active and service fault logs, then clear fault logs and monitor engine operation for the fault to repeat. 3. Inspect sensor, and lines for any damage (eg...burned, broken or frayed wires, cracked or broken connectors or hoses, burned or broken sensors). If damaged, replace the sensor per the “Sensor Replacement Procedures” section in Chapter 72-70. If no damage is found, go to step 4. 4. Inspect harness connection for any damage (eg...burned, broken or frayed wires, cracked or broken connectors). Contact Lycoming if harness damage is found. If no damage found, go to step 5. 5. Swap affected sensor ((A036 or A045) with opposite sensor. Run the engine. Does the fault move with the sensor? If yes, replace the sensor. If no, go to step 6. 6. Complete a continuity test of the harness from the harness sensor connector to the ECU connector using the engine system schematic. If the continuity check fails, isolate to affected harness by disconnecting the firewall connection, then contact Lycoming Engines. If the continuity checks good, replace the sensor. If fault persists, replace the ECU. <p>*NOTE: This fault could be caused by another deck pressure fault. If there are any other active deck pressure faults go to troubleshooting steps for the corresponding deck pressure fault.</p>					

Fault ID	153	Fault Group	20	Fault Name	<i>[FAULT: local compressor inlet air pressure slew rate]</i>
Fault Description	Local compressor inlet pressure slew rate fault			Fault Lamp	None
Root Cause	This fault indicates the pressure sensor slew rate is greater than the calibrated maximum.				
Troubleshooting Steps					
<ol style="list-style-type: none"> 1. Run the engine in accordance with the engine and aircraft maintenance manuals. Is the fault active? * If yes, go to step 3. If no, go to step 2. 2. Using the FST, download active and service fault logs, then clear fault logs and monitor engine operation for the fault to repeat. 3. Inspect sensor, and lines for any damage (eg...burned, broken or frayed wires, cracked or broken connectors or hoses, burned or broken sensors). If damaged, replace the sensor per the “Sensor Replacement Procedures” section in Chapter 72-70. If no damage is found, go to step 4. 4. Inspect harness connection for any damage (eg...burned, broken or frayed wires, cracked or broken connectors). Contact Lycoming if harness damage is found. If no damage found, go to step 5. 5. Swap affected sensor ((A037 or A038) with opposite sensor. Run the engine. Does the fault move with the sensor? If yes, replace the sensor. If no, go to step 6. 6. Complete a continuity test of the harness from the harness sensor connector to the ECU connector using the engine system schematic. If the continuity check fails, isolate to affected harness by disconnecting the firewall connection, then contact Lycoming Engines. If the continuity checks good, replace the sensor. If fault persists, replace the ECU. <p>*NOTE: This fault could be caused by another compressor inlet air pressure fault. If there are any other active compressor inlet air pressure faults go to troubleshooting steps for the corresponding compressor inlet air pressure fault.</p>					

Fault ID	154	Fault Group	20	Fault Name	<i>[FAULT: engine oil pressure slew rate]</i>
Fault Description	Engine Oil pressure slew rate fault			Fault Lamp	None
Root Cause	This fault indicates the pressure sensor slew rate is greater than the calibrated maximum.				
Troubleshooting Steps					
<ol style="list-style-type: none"> 1. Run the engine in accordance with the engine and aircraft maintenance manuals. Is the fault active? * If yes, go to step 3. If no, go to step 2. 2. Using the FST, download active and service fault logs, then clear fault logs and monitor engine operation for the fault to repeat. 3. Inspect sensor, and lines for any damage (eg...burned, broken or frayed wires, cracked or broken connectors or hoses, burned or broken sensors). If damaged, replace the sensor per the “Sensor Replacement Procedures” section in Chapter 72-70. If no damage is found, go to step 4. 4. Inspect harness connection for any damage (eg...burned, broken or frayed wires, cracked or broken connectors). Contact Lycoming if harness damage is found. If no damage found, go to step 5. 5. Complete a continuity test of the harness from the harness sensor connector to the ECU connector using the engine system schematic. If the continuity check fails, isolate to affected harness by disconnecting the firewall connection, then contact Lycoming Engines. If the continuity checks good, replace the sensor. If fault persists, replace the ECU. <p>*NOTE: This fault could be caused by another oil pressure fault. If there are any other active oil pressure faults go to troubleshooting steps for the corresponding oil pressure fault.</p>					

Fault ID	155	Fault Group	20	Fault Name	<i>[FAULT: analogue engine identifier slew rate]</i>
Fault Description	Analogue engine identifier slew rate fault			Fault Lamp	None
Root Cause	This fault indicates the engine identifier slew rate is greater than the calibrated maximum.				
Troubleshooting Steps					
<ol style="list-style-type: none"> 1. Run the engine in accordance with the engine and aircraft maintenance manuals. Is the fault active? If yes, go to step 2. If no, go to step 4. 2. With Ignition switch in OFF position, remove ECU power by pulling the ECU circuit breaker. Wait 10s before resetting. Is fault still active? If yes, go to step 3. If no, monitor engine operation for the fault to repeat. 3. Remove harness connector A001-P2 from ECU connector A001-J2. Using a multi-meter, check for continuity (or a specific resistance if a resistor is installed) between pins 33 and 42 of A001-P2. Does continuity (or correct resistance) exist? If yes, reconnect A001-J2, and go to step 4. If no, contact Lycoming Engines. 4. Clear Service fault history and start engine. If the fault is still active replace the ECU. <p>NOTE: By default, this configurable parameter has been disabled hence this fault should only occur if this is enabled in the calibration for an engine specific installation.</p>					

Fault ID	156	Fault Group	20	Fault Name	<i>[FAULT: fuel rail pressure slew rate]</i>
Fault Description	Fuel rail pressure slew rate fault			Fault Lamp	None
Root Cause	This fault indicates the pressure sensor slew rate is greater than the calibrated maximum.				
Troubleshooting Steps					
<ol style="list-style-type: none"> 1. Run the engine in accordance with the engine and aircraft maintenance manuals. Is the fault active? * If yes, go to step 3. If no, go to step 2. 2. Using the FST, download active and service fault logs, then clear fault logs and monitor engine operation for the fault to repeat. 3. Inspect sensor, and lines for any damage (eg...burned, broken or frayed wires, cracked or broken connectors or hoses, burned or broken sensors). If damage is found, replace the damaged part per the "Sensor Replacement Procedures" section in Chapter 72-70. If no damage is found, go to step 4. 4. Inspect harness connection for any damage (eg...burned, broken or frayed wires, cracked or broken connectors). Contact Lycoming if harness damage is found. If no damage found, go to step 5. 5. Swap fuel rail pressure sensor with fuel pump pressure sensor and run the engine. Does the fault move with the sensor? If yes, replace the sensor. If no, go to step 6. 6. Complete a continuity test of the harness from the harness sensor connector to the ECU connector using the engine system schematic. If the continuity check fails, isolate to affected harness by disconnecting the firewall connection, then contact Lycoming Engines. If the continuity checks good, replace the sensor. If fault persists, replace the ECU. <p>*NOTE: This fault could be caused by another fuel rail pressure fault. If there are any other active fuel rail pressure faults go to troubleshooting steps for the corresponding fuel pressure fault.</p>					

Fault ID	157	Fault Group	20	Fault Name	<i>[FAULT: fuel pump pressure slew rate]</i>
Fault Description	Fuel pump pressure slew rate fault			Fault Lamp	None
Root Cause	This fault indicates the pressure sensor slew rate is greater than the calibrated maximum.				
Troubleshooting Steps					
<ol style="list-style-type: none"> 1. Run the engine in accordance with the engine and aircraft maintenance manuals. Is the fault active? * If yes, go to step 3. If no, go to step 2. 2. Using the FST, download active and service fault logs, then clear fault logs and monitor engine operation for the fault to repeat. 3. Inspect sensor, and lines for any damage (eg...burned, broken or frayed wires, cracked or broken connectors or hoses, burned or broken sensors). If damage is found, replace the damaged part per the "Sensor Replacement Procedures" section in Chapter 72-70. If no damage is found, go to step 4. 4. Inspect harness connection for any damage (eg...burned, broken or frayed wires, cracked or broken connectors). Contact Lycoming if harness damage is found. If no damage found, go to step 5. 5. Swap fuel pump pressure sensor with fuel rail pressure sensor and run the engine. Does the fault move with the sensor? If yes, replace the sensor. If no, go to step 6. 6. Complete a continuity test of the harness from the harness sensor connector to the ECU connector using the engine system schematic. If the continuity check fails, isolate to affected harness by disconnecting the firewall connection, then contact Lycoming Engines. If the continuity checks good, replace the sensor. If fault persists, replace the ECU. <p>*NOTE: This fault could be caused by another fuel pump pressure fault. If there are any other active fuel pump pressure faults go to troubleshooting steps for the corresponding fuel pressure fault.</p>					

Fault ID	158	Fault Group	20	Fault Name	<i>[FAULT: local throttle position slew rate]</i>
Fault Description	Local throttle position slew rate fault			Fault Lamp	None
Root Cause	This fault indicates the throttle position sensor slew rate is greater than the calibrated maximum.				
Troubleshooting Steps					
<ol style="list-style-type: none"> 1. Run the engine in accordance with the engine and aircraft maintenance manuals. Is the fault active? * If yes, go to step 3. If no, go to step 2. 2. Using the FST, download active and service fault logs, then clear fault logs and monitor engine operation for the fault to repeat. 3. Inspect throttle position sensor and throttle body for damage. If damage is found, replace the damaged part** per the "Sensor Replacement Procedures" section in Chapter 72-70 or the "(Electronic) Throttle Body Replacement" section in Chapter 73-20. If no damage is found, go to step 4. 4. Inspect harness connection for any damage (eg...burned, broken or frayed wires, cracked or broken connectors). Contact Lycoming if harness damage is found. If no damage found, go to step 5. 5. Complete a continuity test of the harness from the harness sensor connector to the ECU connector using the engine system schematic. If the continuity check fails, isolate to affected harness by disconnecting the firewall connection, then contact Lycoming Engines. If the continuity checks good, throttle body**. If fault persists, replace the ECU. <p>*NOTE: This fault could be caused by another throttle position fault. If there are any other active throttle position faults, go to troubleshooting steps for the corresponding oil pressure fault.</p> <p>**NOTE: The throttle position sensor is part of throttle body assembly and required replacing the entire throttle body if damaged or defective.</p>					

Fault ID	159	Fault Group	20	Fault Name	<i>[FAULT: analogue pilot operating mode slew rate]</i>												
Fault Description	Primary: -reserved- Secondary: Operating Mode Selector Slew Rate Fault		Fault Lamp	None													
Root Cause	This fault indicates pilot operating mode slew rate is greater than the calibrated maximum																
Troubleshooting Steps																	
<ol style="list-style-type: none"> Is there an active fault(s) that correspond to the fault numbers listed in the Root Cause box, items 1 and 2? If yes, go to troubleshooting procedure for the active fault(s). If no, go to step 2. Inspect wires and resistors connected to switch for breaks or damage. Are wires or resistors broken or damaged? If yes, repair in accordance with the aircraft maintenance manual. If no, go to step 3. Disconnect wires from switch and disconnect ECU connector A001-P2. Measure resistance from A001-P2 pin 48 to each wire and check for resistance as shown in the table below. Are the resistances measured within the table limits? If yes, go to step 4. If no, but resistance is present and not within table limits, replace the defective resistor in accordance with the aircraft maintenance manual. If no, and circuit is open, go to step 5. <table border="1" data-bbox="228 737 878 879" style="margin: 10px auto;"> <thead> <tr> <th>Switch Position</th> <th>Resistance</th> <th>Tolerance</th> </tr> </thead> <tbody> <tr> <td>C</td> <td>330kΩ</td> <td>±10%</td> </tr> <tr> <td>NORM</td> <td>1.01MΩ</td> <td>±10%</td> </tr> <tr> <td>S</td> <td>3.21MΩ</td> <td>±10%</td> </tr> </tbody> </table> Complete a continuity and short circuit test of the switch. If the continuity or short circuit check fails, replace the switch. If the continuity check is good, replace the ECU. Complete a continuity test of the harness from the input side of each resistor to the ECU connector using the engine system schematic. If the continuity check fails, isolate to affected harness by disconnecting the airframe interface connection AF-P1. If the continuity fails between switch and AF-J1, repair cable in accordance with aircraft maintenance manual. If the continuity fails between AF-P1 and ECU, contact Lycoming Engines. If the continuity checks good, replace the ECU. 						Switch Position	Resistance	Tolerance	C	330kΩ	±10%	NORM	1.01MΩ	±10%	S	3.21MΩ	±10%
Switch Position	Resistance	Tolerance															
C	330kΩ	±10%															
NORM	1.01MΩ	±10%															
S	3.21MΩ	±10%															

Fault ID	160	Fault Group	21	Fault Name	<i>[FAULT: 5V sensor supply 1 slew rate]</i>
Fault Description	5V sensor supply 1 slew rate fault		Fault Lamp	None	
Root Cause	This fault indicates 5V sensor supply 1 slew rate is greater than the calibrated maximum				
Troubleshooting Steps					
<ol style="list-style-type: none"> With Ignition switch in OFF position, remove ECU power by pulling the ECU circuit breaker. Wait 10s before resetting. Is fault still active or repetitive? If yes, go to step 2. If no, monitor engine operation for the fault to repeat. If fault repeats, go to step 2. If fault is still active or repetitive, but is not affecting engine operation, contact Lycoming for further assistance. If fault affects engine operation (ie... causes other faults), replace the ECU. 					

Fault ID	161	Fault Group	21	Fault Name	<i>[FAULT: 5V sensor supply 2 slew rate]</i>
Fault Description	5V sensor supply 2 slew rate fault		Fault Lamp	None	
Root Cause	This fault indicates 5V sensor supply 2 slew rate is greater than the calibrated maximum				
Troubleshooting Steps					
<ol style="list-style-type: none"> With Ignition switch in OFF position, remove ECU power by pulling the ECU circuit breaker. Wait 10s before resetting. Is fault still active or repetitive? If yes, go to step 2. If no, monitor engine operation for the fault to repeat. If fault repeats, go to step 2. If fault is still active or repetitive, but is not affecting engine operation, contact Lycoming for further assistance. If fault affects engine operation (ie... causes other faults), replace the ECU. 					

Fault ID	162	Fault Group	21	Fault Name	<i>[FAULT: 5V sensor supply 3 slew rate]</i>
Fault Description	5V sensor supply 3 slew rate fault			Fault Lamp	None
Root Cause	This fault indicates 5V sensor supply 3 slew rate is greater than the calibrated maximum				
Troubleshooting Steps					
<ol style="list-style-type: none"> 1. With Ignition switch in OFF position, remove ECU power by pulling the ECU circuit breaker. Wait 10s before resetting. Is fault still active or repetitive? If yes, go to step 2. If no, monitor engine operation for the fault to repeat. If fault repeats, go to step 2. 2. If fault is still active or repetitive, but is not affecting engine operation, contact Lycoming for further assistance. If fault affects engine operation (ie... causes other faults), replace the ECU. 					

Fault ID	163	Fault Group	21	Fault Name	<i>[FAULT: thermocouple offset voltage slew rate]</i>
Fault Description	Thermocouple offset voltage slew rate			Fault Lamp	None
Root Cause	This fault indicates thermocouple offset voltage slew rate is greater than the calibrated maximum				
Troubleshooting Steps					
<ol style="list-style-type: none"> 1. Run the engine in accordance with the engine and aircraft maintenance manuals. Vary the throttle setting to allow the EGT, CHT, and TIT to increase and decrease with engine operation. Is the fault active?* 2. Using the FST, download active and service fault logs, then clear fault logs and monitor engine operation for the fault to repeat. 3. If the fault is active and no other associated faults exist, replace the ECU. 					
*NOTE: This fault is usually associated with another thermocouple fault. If there are any other active thermocouple faults, go to troubleshooting steps for the corresponding fault.					

Fault ID	164	Fault Group	21	Fault Name	<i>[FAULT: ECU supply voltage slew rate]</i>
Fault Description	ECU supply voltage slew rate			Fault Lamp	None
Root Cause	This fault indicates ECU supply voltage slew rate is greater than the calibrated maximum				
Troubleshooting Steps					
<ol style="list-style-type: none"> 1. With Ignition switch in OFF position, remove ECU power by pulling the ECU circuit breaker. Wait 10s before resetting. Is fault still active or repetitive? If yes, go to step 2. If no, monitor engine operation for the fault to repeat. If fault repeats, go to step 2. 2. If fault is still active or repetitive, but is not affecting engine operation, contact Lycoming for further assistance. If fault affects engine/ECU operation (ie... causes other faults, affects performance), replace the Power Box. 					

Fault ID	165	Fault Group	21	Fault Name	<i>[FAULT: actuator supply voltage slew rate]</i>
Fault Description	Actuator supply voltage slew rate			Fault Lamp	None
Root Cause	This fault indicates actuator supply voltage slew rate is greater than the calibrated maximum				
Troubleshooting Steps					
<ol style="list-style-type: none"> 1. With Ignition switch in OFF position, remove ECU power by pulling the ECU circuit breaker. Wait 10s before resetting. Is fault still active or repetitive? If yes, go to step 2. If no, monitor engine operation for the fault to repeat. If fault repeats, go to step 2. 2. If fault is still active or repetitive, but is not affecting engine operation, contact Lycoming for further assistance. If fault affects engine/ECU operation (i.e...causes other faults, affects performance), replace the Power Box. 					

Fault ID	166	Fault Group	21	Fault Name	<i>-Reserved-</i>
Fault Description				Fault Lamp	None
Root Cause					
Troubleshooting Steps					

Fault ID	167	Fault Group	21	Fault Name	<i>-Reserved-</i>
Fault Description				Fault Lamp	None
Root Cause					
Troubleshooting Steps					

Fault ID	168	Fault Group	22	Fault Name	<i>[FAULT: ACJ temperature slew rate]</i>
Fault Description	ACJ temperature voltage slew rate			Fault Lamp	None
Root Cause	This fault indicates ACJ (Auto Cold Junction) temperature slew rate is greater than the calibrated maximum				
Troubleshooting Steps					
<ol style="list-style-type: none"> 1. With Ignition switch in OFF position, remove ECU power by pulling the ECU circuit breaker. Wait 10s before resetting. Is fault still active or repetitive? If yes, go to step 2. If no, monitor engine operation for the fault to repeat. If fault repeats, go to step 2. 2. Check area surrounding ECU and Power Box to ensure there is nothing that could be causing a rapid temperature change. If something is found, correct discrepancy. If nothing is found, go to step 3. 3. If fault is still active or repetitive, but is not affecting engine operation, contact Lycoming for further assistance. If fault affects engine operation (ie... causes other faults), replace the ECU. 					

Fault ID	169	Fault Group	22	Fault Name	<i>[FAULT: ECU temperature slew rate]</i>
Fault Description	ECU temperature voltage slew rate			Fault Lamp	None
Root Cause	This fault indicates ECU temperature slew rate is greater than the calibrated maximum				
Troubleshooting Steps					
<ol style="list-style-type: none"> 1. With Ignition switch in OFF position, remove ECU power by pulling the ECU circuit breaker. Wait 10s before resetting. Is fault still active or repetitive? If yes, go to step 2. If no, monitor engine operation for the fault to repeat. If fault repeats, go to step 2. 2. Check area surrounding ECU and Power Box to ensure there is nothing that could be causing a rapid temperature change. If something is found, correct discrepancy. If nothing is found, go to step 3. 3. If fault is still active or repetitive, but is not affecting engine operation, contact Lycoming for further assistance. If fault affects engine operation (ie... causes other faults), replace the ECU. 					

Fault ID	170	Fault Group	22	Fault Name	<i>-Reserved-</i>
Fault Description				Fault Lamp	None
Root Cause					
Troubleshooting Steps					

Fault ID	171	Fault Group	22	Fault Name	<i>-Reserved-</i>
Fault Description				Fault Lamp	None
Root Cause					
Troubleshooting Steps					

Fault ID	172	Fault Group	22	Fault Name	<i>-Reserved-</i>
Fault Description				Fault Lamp	None
Root Cause					
Troubleshooting Steps					

Fault ID	173	Fault Group	22	Fault Name	<i>-Reserved-</i>
Fault Description				Fault Lamp	None
Root Cause					
Troubleshooting Steps					

Fault ID	174	Fault Group	22	Fault Name	<i>-Reserved-</i>
Fault Description				Fault Lamp	None
Root Cause					
Troubleshooting Steps					

Fault ID	175	Fault Group	22	Fault Name	<i>-Reserved-</i>
Fault Description				Fault Lamp	None
Root Cause					
Troubleshooting Steps					

Fault ID	176	Fault Group	23	Fault Name	<i>[FAULT: AN2 circuit]</i>
Fault Description	Primary CHT Cylinder 1 Circuit Fault Secondary CHT Cylinder 2 Circuit Fault			Fault Lamp	FFL
Fault ID	177	Fault Group	23	Fault Name	<i>[FAULT: AN3 circuit]</i>
Fault Description	Primary CHT Cylinder 3 Circuit Fault Secondary CHT Cylinder 4 Circuit Fault			Fault Lamp	FFL
Fault ID	178	Fault Group	23	Fault Name	<i>[FAULT: AN4 circuit]</i>
Fault Description	Primary CHT Cylinder 5 Circuit Fault Secondary CHT Cylinder 6 Circuit Fault			Fault Lamp	FFL
Fault ID	179	Fault Group	23	Fault Name	<i>[FAULT: AN5 circuit]</i>
Fault Description	Primary CHT Cylinder 7 Circuit Fault Secondary CHT Cylinder 8 Circuit Fault			Fault Lamp	FFL
Fault ID	180	Fault Group	23	Fault Name	<i>[FAULT: AN6 circuit]</i>
Fault Description	Primary EGT Cylinder 2 Circuit Fault Secondary EGT Cylinder 1 Circuit Fault			Fault Lamp	FFL
Fault ID	181	Fault Group	23	Fault Name	<i>[FAULT: AN7 circuit]</i>
Fault Description	Primary EGT Cylinder 4 Circuit Fault Secondary EGT Cylinder 3 Circuit Fault			Fault Lamp	FFL
Fault ID	182	Fault Group	23	Fault Name	<i>[FAULT: AN8 circuit]</i>
Fault Description	Primary EGT Cylinder 6 Circuit Fault Secondary EGT Cylinder 5 Circuit Fault			Fault Lamp	FFL
Fault ID	183	Fault Group	23	Fault Name	<i>[FAULT: AN9 circuit]</i>
Fault Description	Primary EGT Cylinder 8 Circuit Fault Secondary EGT Cylinder 7 Circuit Fault			Fault Lamp	FFL
Root Cause	<p>This fault occurs if the Raw voltage observed on the input is outside the expected window defined by the calibratable Highest and Lowest Valid Raw voltage values.</p> <p>This does not distinguish between Open and Short Circuit Faults as any of the following failures would result in the Raw voltage outside the expected voltage window:</p> <ul style="list-style-type: none"> - Open Circuit - Short to GND 				
Troubleshooting Steps					
<ol style="list-style-type: none"> 1. Run the engine in accordance with the engine and aircraft maintenance manuals. Is the fault active? * If yes, go to step 3. If no, go to step 2. 2. Using the FST, download active and service fault logs, then clear fault logs and monitor engine operation for the fault to repeat. 3. Inspect the sensor, sensor connector and lead. If any are damaged, replace the sensor per the “Sensor Replacement Procedure” in Chapter 72-70. If there is no damage, go to step 4. 4. Inspect engine harness for visible signs of damage. If damage is found, contact Lycoming Engines. If no damage is found, go to step 5. 5. Swap the sensor from the channel giving the fault with another sensor in a different cylinder, and run the engine. Did the fault move with the sensor? If yes, replace the sensor per the “Sensor Replacement Procedure” in Chapter 72-70. If no, complete a continuity test of the harness from the harness sensor connector to the ECU connector using the engine system schematic. If the continuity check fails, isolate to affected harness by disconnecting the firewall connection, then contact Lycoming Engines. If the continuity checks good, replace the ECU. <p>*NOTE: The steps listed above are for troubleshooting a single fault event. If there are faults on multiple thermocouples, check to see if there are any active faults for ECU ACJ offset or internal power supply. If there are any other active faults, as those just mentioned, proceed to the troubleshooting of those faults.</p>					

Fault ID	184	Fault Group	24	Fault Name	<i>[FAULT: AN10 circuit]</i>
Fault Description	Primary TIT1 Circuit Fault Secondary TIT2 Circuit Fault		Fault Lamp	TLO	
Root Cause	This fault occurs if the Raw voltage observed on the input is outside the expected window defined by the calibratable Highest and Lowest Valid Raw voltage values. This does not distinguish between Open and Short Circuit Faults as any of the following failures would result in the Raw voltage outside the expected voltage window: <ul style="list-style-type: none"> - Open Circuit - Short to GND 				

Troubleshooting Steps

1. Run the engine in accordance with the engine and aircraft maintenance manuals. Is the fault active? * If yes, go to step 3. If no, go to step 2.
2. Using the FST, download active and service fault logs, then clear fault logs and monitor engine operation for the fault to repeat.
3. Inspect the sensor, sensor connector and lead. If any are damaged, replace the sensor i per the “Sensor Replacement Procedure” in Chapter 72-70. If there is no damage, go to step 4.
4. Inspect engine harness for visible signs of damage. If damage is found, contact Lycoming Engines. If no damage is found, go to step 5.
5. Swap the sensor from the channel giving the fault with another sensor in a different position and run the engine. Did the fault move with the sensor? If yes, replace the sensor per the “Sensor Replacement Procedure” in Chapter 72-70. If no, complete a continuity test of the harness from the harness sensor connector to the ECU connector using the engine system schematic. If the continuity check fails, isolate to affected harness by disconnecting the firewall connection, then contact Lycoming Engines. If the continuity checks good, replace the ECU.

*NOTE: The steps listed above are for troubleshooting a single fault event. If there are faults on multiple thermocouples, check to see if there are any active faults for ECU ACJ offset or internal power supply. If there are any other active faults, as those just mentioned, proceed to the troubleshooting of those faults.

Fault ID	185	Fault Group	24	Fault Name	<i>[FAULT: AN16 circuit]</i>
Fault Description	Primary MAT (Manifold Air Temperature) Circuit Fault Secondary MAT Circuit Fault		Fault Lamp	TLO	
Root Cause	This fault occurs if the Raw voltage observed on the input is outside the expected window defined by the calibratable Highest and Lowest Valid Raw voltage values. This does not distinguish between Open and Short Circuit Faults as any of the following failures would result in the Raw voltage outside the expected voltage window: <ul style="list-style-type: none"> - Open Circuit - Short to VPwr - Short to 5V - Short to GND 				

Troubleshooting Steps

1. Run the engine in accordance with the engine and aircraft maintenance manuals. Is the fault active? If yes, go to step 3. If no, go to step 2.
2. Using the FST, download active and service fault logs, then clear fault logs and monitor engine operation for the fault to repeat.
3. Inspect the sensor, sensor connector and lead. If any are damaged, replace the sensor per the “Sensor Replacement Procedure” in Chapter 72-70. If there is no damage, go to step 4.
4. Inspect engine harness for visible signs of damage. If damage is found, contact Lycoming Engines. If no damage is found, go to step 5.
5. Swap the sensor from the channel giving the fault with another sensor in a different position and run the engine. Did the fault move with the sensor? If yes, replace the sensor per the “Sensor Replacement Procedure” in Chapter 72-70. If no, complete a continuity test of the harness from the harness sensor connector to the ECU connector using the engine system schematic. If the continuity check fails, isolate to affected harness by disconnecting the firewall connection, then contact Lycoming Engines. If the continuity checks good, replace the ECU.

Fault ID	186	Fault Group	24	Fault Name	[FAULT: AN17 circuit]
Fault Description	Primary Deck Temperature Circuit Fault Secondary -reserved-			Fault Lamp	TLO
Root Cause	<p>This fault occurs if the Raw voltage observed on the input is outside the expected window defined by the calibratable Highest and Lowest Valid Raw voltage values. This does not distinguish between Open and Short Circuit Faults as any of the following failures would result in the Raw voltage outside the expected voltage window:</p> <ul style="list-style-type: none"> - Open Circuit - Short to VPwr - Short to 5V - Short to GND 				
Troubleshooting Steps					
<ol style="list-style-type: none"> 1. Run the engine in accordance with the engine and aircraft maintenance manuals. Is the fault active? If yes, go to step 3. If no, go to step 2. 2. Using the FST, download active and service fault logs, then clear fault logs and monitor engine operation for the fault to repeat. 3. Inspect the sensor, sensor connector and lead. If any are damaged, replace the sensor per the “Sensor Replacement Procedure” in Chapter 72-70. If there is no damage, go to step 4. 4. Inspect engine harness for visible signs of damage. If damage is found, contact Lycoming Engines. If no damage is found, go to step 5. 5. Swap the sensor from the channel giving the fault with another sensor in a different position and run the engine. Did the fault move with the sensor? If yes, replace the sensor per the “Sensor Replacement Procedure” in Chapter 72-70. If no, complete a continuity test of the harness from the harness sensor connector to the ECU connector using the engine system schematic. If the continuity check fails, isolate to affected harness by disconnecting the firewall connection, then contact Lycoming Engines. If the continuity checks good, replace the ECU. 					

Fault ID	187	Fault Group	24	Fault Name	[FAULT: AN18 circuit]
Fault Description	Primary: FRT (Fuel Rail Temp.) Circuit Fault Secondary -reserved-			Fault Lamp	TLO
Root Cause	<p>This fault occurs if the Raw voltage observed on the input is outside the expected window defined by the calibratable Highest and Lowest Valid Raw voltage values. This does not distinguish between Open and Short Circuit Faults as any of the following failures would result in the Raw voltage outside the expected voltage window:</p> <ul style="list-style-type: none"> - Open Circuit - Short to VPwr - Short to 5V - Short to GND 				
Troubleshooting Steps					
<ol style="list-style-type: none"> 1. Run the engine in accordance with the engine and aircraft maintenance manuals. Is the fault active? If yes, go to step 3. If no, go to step 2. 2. Using the FST, download active and service fault logs, then clear fault logs and monitor engine operation for the fault to repeat. 3. Inspect the sensor and sensor connector. If either is damaged, replace the sensor per the “Sensor Replacement Procedure” in Chapter 72-70. If there is no damage, go to step 4. 4. Inspect engine harness for visible signs of damage. If damage is found, contact Lycoming Engines. If no damage is found, go to step 5. 5. Swap the fuel rail temp sensor with the oil temperature sensor (A026) and run the engine. Is there now an active oil temperature circuit fault? If yes, replace the sensor per the “Sensor Replacement Procedure” in Chapter 72-70. If no, complete a continuity test of the harness from the harness sensor connector to the ECU connector using the engine system schematic. If the continuity check fails, isolate to affected harness by disconnecting the firewall connection, then contact Lycoming Engines. If the continuity checks good, replace the ECU. 					

Fault ID	188	Fault Group	24	Fault Name	<i>[FAULT: AN19 circuit]</i>
Fault Description	Primary: -reserved- Secondary: EOT (Engine Oil Temp.) Circuit Fault			Fault Lamp	TLO
Root Cause	This fault occurs if the Raw voltage observed on the input is outside the expected window defined by the calibratable Highest and Lowest Valid Raw voltage values. This does not distinguish between Open and Short Circuit Faults as any of the following failures would result in the Raw voltage outside the expected voltage window: <ul style="list-style-type: none"> - Open Circuit - Short to VPwr - Short to 5V - Short to GND 				
Troubleshooting Steps					
1. Run the engine in accordance with the engine and aircraft maintenance manuals. Is the fault active? If yes, go to step 3. If no, go to step 2. 2. Using the FST, download active and service fault logs, then clear fault logs and monitor engine operation for the fault to repeat. 3. Inspect the sensor and sensor connector. If either is damaged, replace the sensor per the “Sensor Replacement Procedure” in Chapter 72-70. If there is no damage, go to step 4. 4. Inspect engine harness for visible signs of damage. If damage is found, contact Lycoming Engines. If no damage is found, go to step 5. 5. Swap the oil temperature sensor with the fuel rail temp sensor (A012) and run the engine. Is there now an active fuel rail temp circuit fault? If yes, replace the sensor per the “Sensor Replacement Procedure” in Chapter 72-70. If no, complete a continuity test of the harness from the harness sensor connector to the ECU connector using the engine system schematic. If the continuity check fails, isolate to affected harness by disconnecting the firewall connection, then contact Lycoming Engines. If the continuity checks good, replace the ECU.					
Fault ID	189	Fault Group	24	Fault Name	<i>[FAULT: AN20 circuit]</i>
Fault Description	Primary: Venturi Pressure Circuit Fault Secondary: Manifold Pressure Circuit Fault			Fault Lamp	TLO
Root Cause	This fault occurs if the Raw voltage observed on the input is outside the expected window defined by the calibratable Highest and Lowest Valid Raw voltage values. This does not distinguish between Open and Short Circuit Faults as any of the following failures would result in the Raw voltage outside the expected voltage window: <ul style="list-style-type: none"> - Open Circuit - Short to VPwr - Short to 5V - Short to GND 				
Troubleshooting Steps					
1. Run the engine in accordance with the engine and aircraft maintenance manuals. Is the fault active? If yes, go to step 3. If no, go to step 2. 2. Using the FST, download active and service fault logs, then clear fault logs and monitor engine operation for the fault to repeat. 3. Inspect the sensor and sensor connector. If either is damaged, replace the sensor per the “Sensor Replacement Procedure” in Chapter 72-70. If there is no damage, go to step 4. 4. Inspect engine harness for visible signs of damage. If damage is found, contact Lycoming Engines. If no damage is found, go to step 5. 5. Swap the sensor from the channel giving the fault with another sensor in a different position and run the engine. Did the fault move with the sensor? If yes, replace the sensor per the “Sensor Replacement Procedure” in Chapter 72-70. If no, complete a continuity test of the harness from the harness sensor connector to the ECU connector using the engine system schematic. If the continuity check fails, isolate to affected harness by disconnecting the firewall connection, then contact Lycoming Engines. If the continuity checks good, replace the ECU.					

Fault ID	190	Fault Group	24	Fault Name	[FAULT: AN21 circuit]
Fault Description	Primary: Deck Pressure Circuit Fault Secondary: Deck Pressure Circuit Fault		Fault Lamp	TLO	
Root Cause	<p>This fault occurs if the Raw voltage observed on the input is outside the expected window defined by the calibratable Highest and Lowest Valid Raw voltage values.</p> <p>This does not distinguish between Open and Short Circuit Faults as any of the following failures would result in the Raw voltage outside the expected voltage window:</p> <ul style="list-style-type: none"> - Open Circuit - Short to 5V - Short to VPwr - Short to GND 				
Troubleshooting Steps					
<ol style="list-style-type: none"> 1. Run the engine in accordance with the engine and aircraft maintenance manuals. Is the fault active? If yes, go to step 3. If no, go to step 2. 2. Using the FST, download active and service fault logs, then clear fault logs and monitor engine operation for the fault to repeat. 3. Inspect the sensor and sensor connector. If either is damaged, replace the sensor per the “Sensor Replacement Procedure” in Chapter 72-70. If there is no damage, go to step 4. 4. Inspect engine harness for visible signs of damage. If damage is found, contact Lycoming Engines. If no damage is found, go to step 5. 5. Swap the sensor from the channel giving the fault with another sensor in a different position and run the engine. Did the fault move with the sensor? If yes, replace the sensor per the “Sensor Replacement Procedure” in Chapter 72-70. If no, complete a continuity test of the harness from the harness sensor connector to the ECU connector using the engine system schematic. If the continuity check fails, isolate to affected harness by disconnecting the firewall connection, then contact Lycoming Engines. If the continuity checks good, replace the ECU. 6. If the above steps are unsuccessful, contact Lycoming 					

Fault ID	191	Fault Group	24	Fault Name	[FAULT: AN22 circuit]
Fault Description	Primary: CIP (Compressor Inlet Pressure) Circuit Fault Secondary: CIP Circuit Fault		Fault Lamp	TLO	
Root Cause	<p>This fault occurs if the Raw voltage observed on the input is outside the expected window defined by the calibratable Highest and Lowest Valid Raw voltage values.</p> <p>This does not distinguish between Open and Short Circuit Faults as any of the following failures would result in the Raw voltage outside the expected voltage window:</p> <ul style="list-style-type: none"> - Open Circuit - Short to 5V - Short to VPwr - Short to GND 				
Troubleshooting Steps					
<ol style="list-style-type: none"> 1. Run the engine in accordance with the engine and aircraft maintenance manuals. Is the fault active? If yes, go to step 3. If no, go to step 2. 2. Using the FST, download active and service fault logs, then clear fault logs and monitor engine operation for the fault to repeat. 3. Inspect the sensor and sensor connector. If either is damaged, replace the sensor per the “Sensor Replacement Procedure” in Chapter 72-70. If there is no damage, go to step 4. 4. Inspect engine harness for visible signs of damage. If damage is found, contact Lycoming Engines. If no damage is found, go to step 5. 5. Swap the sensor from the channel giving the fault with another sensor in a different position and run the engine. Did the fault move with the sensor? If yes, replace the sensor per the “Sensor Replacement Procedure” in Chapter 72-70. If no, complete a continuity test of the harness from the harness sensor connector to the ECU connector using the engine system schematic. If the continuity check fails, isolate to affected harness by disconnecting the firewall connection, then contact Lycoming Engines. If the continuity checks good, replace the ECU. 6. If the above steps are unsuccessful, contact Lycoming 					

Fault ID	192	Fault Group	25	Fault Name	[FAULT: AN23 circuit]
Fault Description	Primary: EOP (Engine Oil Pressure) Circuit Fault Secondary: Engine ID Circuit Fault*			Fault Lamp	TLO
Root Cause	This fault occurs if the Raw voltage observed on the input is outside the expected window defined by the calibratable Highest and Lowest Valid Raw voltage values. This does not distinguish between Open and Short Circuit Faults as any of the following failures would result in the Raw voltage outside the expected voltage window: - Open Circuit - Short to 5V - Short to VPwr - Short to GND				
Troubleshooting Steps					
1. Run the engine in accordance with the engine and aircraft maintenance manuals. Is the fault active? If yes, go to step 3. If no, go to step 2. 2. Using the FST, download active and service fault logs, then clear fault logs and monitor engine operation for the fault to repeat. 3. Inspect sensor, and lines for any damage (eg...burned, broken or frayed wires, cracked or broken connectors or hoses, burned or broken sensors). If damaged, replace the sensor per the “Sensor Replacement Procedure” in Chapter 72-70. If no damage is found, go to step 4. 4. Inspect harness connection for any damage (eg...burned, broken or frayed wires, cracked or broken connectors). Contact Lycoming if harness damage is found. If no damage found, go to step 5. 5. Complete a continuity test of the harness from the harness sensor connector to the ECU connector using the engine system schematic. If the continuity check fails, isolate to affected harness by disconnecting the firewall connection, then contact Lycoming Engines. If the continuity checks good, replace the sensor. If fault persists, replace the ECU. *NOTE: If the secondary fault is active, go to troubleshooting procedures for Fault ID 256.					

Fault ID	193	Fault Group	25	Fault Name	[FAULT: AN24 circuit]
Fault Description	Primary: FRP (Fuel Rail Pressure) Circuit Fault Secondary: FPP (Fuel Pump Pressure) Circuit Fault			Fault Lamp	TLO
Root Cause	This fault occurs if the Raw voltage observed on the input is outside the expected window defined by the calibratable Highest and Lowest Valid Raw voltage values. This does not distinguish between Open and Short Circuit Faults as any of the following failures would result in the Raw voltage outside the expected voltage window: - Open Circuit - Short to 5V - Short to VPwr - Short to GND				
Troubleshooting Steps					
1. Run the engine in accordance with the engine and aircraft maintenance manuals. Is the fault active? If yes, go to step 3. If no, go to step 2. 2. Using the FST, download active and service fault logs, then clear fault logs and monitor engine operation for the fault to repeat. 3. Inspect sensor, and lines for any damage (eg...burned, broken or frayed wires, cracked or broken connectors or hoses, burned or broken sensors). If damage is found, replace the damaged part per the “Sensor Replacement Procedure” in Chapter 72-70. If no damage is found, go to step 4. 4. Inspect harness connection for any damage (eg...burned, broken or frayed wires, cracked or broken connectors). Contact Lycoming if harness damage is found. If no damage found, go to step 5. 5. Swap fuel rail pressure sensor with fuel pump pressure sensor and run the engine. Does the fault move with the sensor? If yes, replace the sensor. If no, go to step 6. 6. Complete a continuity test of the harness from the harness sensor connector to the ECU connector using the engine system schematic. If the continuity check fails, isolate to affected harness by disconnecting the firewall connection, then contact Lycoming Engines. If the continuity checks good, replace the sensor. If fault persists, replace the ECU.					

Fault ID	194	Fault Group	25	Fault Name	[FAULT: AN25 circuit]
Fault Description	Primary: FRP Circuit Fault Secondary: FPP Circuit Fault			Fault Lamp	TLO
Root Cause	<p>This fault occurs if the Raw voltage observed on the input is outside the expected window defined by the calibratable Highest and Lowest Valid Raw voltage values. This does not distinguish between Open and Short Circuit Faults as any of the following failures would result in the Raw voltage outside the expected voltage window:</p> <ul style="list-style-type: none"> - Open Circuit - Short to VPwr - Short to 5V - Short to GND 				
Troubleshooting Steps					
<ol style="list-style-type: none"> Run the engine in accordance with the engine and aircraft maintenance manuals. Is the fault active? If yes, go to step 3. If no, go to step 2. Using the FST, download active and service fault logs, then clear fault logs and monitor engine operation for the fault to repeat. Inspect sensor, and lines for any damage (eg...burned, broken or frayed wires, cracked or broken connectors or hoses, burned or broken sensors). If damage is found, replace the damaged part per the "Sensor Replacement Procedure" in Chapter 72-70. If no damage is found, go to step 4. Inspect harness connection for any damage (eg...burned, broken or frayed wires, cracked or broken connectors). Contact Lycoming if harness damage is found. If no damage found, go to step 5. Swap fuel rail pressure sensor with fuel pump pressure sensor and run the engine. Does the fault move with the sensor? If yes, replace the sensor. If no, go to step 6. Complete a continuity test of the harness from the harness sensor connector to the ECU connector using the engine system schematic. If the continuity check fails, isolate to affected harness by disconnecting the firewall connection, then contact Lycoming Engines. If the continuity checks good, replace the sensor. If fault persists, replace the ECU. 					

Fault ID	195	Fault Group	25	Fault Name	[FAULT: AN30 circuit]												
Fault Description	Primary: -reserved- Secondary: Op Mode Selector Circuit Fault			Fault Lamp	TLO												
Root Cause	<p>This fault occurs if the Raw voltage observed on the input is outside the expected window defined by the calibratable Highest and Lowest Valid Raw voltage values. This does not distinguish between Open and Short Circuit Faults as any of the following failures would result in the Raw voltage outside the expected voltage window:</p> <ul style="list-style-type: none"> - Open Circuit - Short to VPwr - Short to 5V - Short to GND 																
Troubleshooting Steps																	
<ol style="list-style-type: none"> Inspect wires and resistors connected to switch for breaks or damage. Are wires or resistors broken or damaged? If yes, repair in accordance with the aircraft maintenance manual. If no, go to step 2. Disconnect wires from switch and disconnect ECU connector A001-P2. Measure resistance from A001-P2 pin 48 to each wire and check for resistance as shown in the table below. Are the resistances measured within the table limits? If yes, go to step 4. If no, but resistance is present and not within table limits, replace the defective resistor in accordance with the aircraft maintenance manual. If no, and circuit is open, go to step 3. 																	
<table border="1"> <thead> <tr> <th>Switch Position</th> <th>Resistance</th> <th>Tolerance</th> </tr> </thead> <tbody> <tr> <td>C</td> <td>330kΩ</td> <td>±10%</td> </tr> <tr> <td>NORM</td> <td>1.01MΩ</td> <td>±10%</td> </tr> <tr> <td>S</td> <td>3.21MΩ</td> <td>±10%</td> </tr> </tbody> </table>						Switch Position	Resistance	Tolerance	C	330kΩ	±10%	NORM	1.01MΩ	±10%	S	3.21MΩ	±10%
Switch Position	Resistance	Tolerance															
C	330kΩ	±10%															
NORM	1.01MΩ	±10%															
S	3.21MΩ	±10%															

Troubleshooting Steps for Fault 195 (Cont.)

3. Complete a continuity and short circuit test of the switch. If the continuity or short circuit check fails, replace the switch. If the continuity check is good, replace the ECU.
4. Complete a continuity test of the harness from the input side of each resistor to the ECU connector using the engine system schematic. If the continuity check fails, isolate to affected harness by disconnecting the airframe interface connection AF-P1. If the continuity fails between switch and AF-J1, repair cable in accordance with aircraft maintenance manual. If the continuity fails between AF-P1 and ECU, contact Lycoming Engines. If the continuity checks good, replace the ECU.

Fault ID	196	Fault Group	25	Fault Name	<i>[FAULT: AN31 circuit]</i>
Fault Description	Primary/Secondary: 5V Sensor Supply 1 Circuit Fault		Fault Lamp	TLO	
Root Cause	This fault occurs if the Raw voltage observed on the input is outside the expected window defined by the calibratable Highest and Lowest Valid Raw voltage values. This does not distinguish between Open and Short Circuit Faults as any of the following failures would result in the Raw voltage outside the expected voltage window: <ul style="list-style-type: none"> - Open Circuit - Short to VPwr - Short to 5V - Short to GND 				
Troubleshooting Steps					
1. With Ignition switch in OFF position, remove ECU power by pulling the ECU circuit breaker. Wait 10s before resetting. Is fault still active or repetitive? If yes, replace the ECU.					

Fault ID	197	Fault Group	25	Fault Name	<i>[FAULT: AN32 circuit]</i>
Fault Description	Primary/Secondary: 5V Sensor Supply 2 Circuit Fault		Fault Lamp	TLO	
Root Cause	This fault occurs if the Raw voltage observed on the input is outside the expected window defined by the calibratable Highest and Lowest Valid Raw voltage values. This does not distinguish between Open and Short Circuit Faults as any of the following failures would result in the Raw voltage outside the expected voltage window: <ul style="list-style-type: none"> - Open Circuit - Short to VPwr - Short to 5V - Short to GND 				
Troubleshooting Steps					
1. With Ignition switch in OFF position, remove ECU power by pulling the ECU circuit breaker. Wait 10s before resetting. Is fault still active or repetitive? If yes, replace the ECU.					

Fault ID	198	Fault Group	25	Fault Name	<i>[FAULT: AN33 circuit]</i>
Fault Description	Primary/Secondary: 5V Sensor Supply 3 Circuit Fault		Fault Lamp	TLO	
Root Cause	This fault occurs if the Raw voltage observed on the input is outside the expected window defined by the calibratable Highest and Lowest Valid Raw voltage values. This does not distinguish between Open and Short Circuit Faults as any of the following failures would result in the Raw voltage outside the expected voltage window: <ul style="list-style-type: none"> - Open Circuit - Short to VPwr - Short to 5V - Short to GND 				
Troubleshooting Steps					
1. With Ignition switch in OFF position, remove ECU power by pulling the ECU circuit breaker. Wait 10s before resetting. Is fault still active or repetitive? If yes, replace the ECU.					

Fault ID	199	Fault Group	25	Fault Name	<i>-Reserved-</i>
Fault Description				Fault Lamp	TLO
Root Cause					
Troubleshooting Steps					

Fault ID	200	Fault Group	26	Fault Name	<i>[FAULT: AN34 circuit]</i>
Fault Description	Primary: ACJ Temperature Circuit Fault Secondary: ACJ Temperature Circuit Fault			Fault Lamp	TLO
Root Cause	This fault occurs if the Raw voltage observed on the input is outside the expected window defined by the calibratable Highest and Lowest Valid Raw voltage values. This does not distinguish between Open and Short Circuit Faults as any of the following failures would result in the Raw voltage outside the expected voltage window: <ul style="list-style-type: none"> - Open Circuit - Short to VPwr - Short to 5V - Short to GND 				
Troubleshooting Steps					
1. With Ignition switch in OFF position, remove ECU power by pulling the ECU circuit breaker. Wait 10s before resetting. Is fault still active or repetitive? If yes, replace the ECU.					

Fault ID	201	Fault Group	26	Fault Name	<i>[FAULT: AN35 circuit]</i>
Fault Description	Primary: Thermocouple Offset Voltage Circuit Fault Secondary: Thermocouple Offset Voltage Circuit Fault			Fault Lamp	TLO
Root Cause	This fault occurs if the Raw voltage observed on the input is outside the expected window defined by the calibratable Highest and Lowest Valid Raw voltage values. This does not distinguish between Open and Short Circuit Faults as any of the following failures would result in the Raw voltage outside the expected voltage window: <ul style="list-style-type: none"> - Open Circuit - Short to VPwr - Short to 5V - Short to GND 				
Troubleshooting Steps					
1. With Ignition switch in OFF position, remove ECU power by pulling the ECU circuit breaker. Wait 10s before resetting. Is fault still active or repetitive? If yes, replace the ECU.					

Fault ID	202	Fault Group	26	Fault Name	<i>[FAULT: AN36 circuit]</i>
Fault Description	Primary/Secondary: ECU Temperature Circuit Fault			Fault Lamp	TLO
Root Cause	This fault occurs if the Raw voltage observed on the input is outside the expected window defined by the calibratable Highest and Lowest Valid Raw voltage values. This does not distinguish between Open and Short Circuit Faults as any of the following failures would result in the Raw voltage outside the expected voltage window: <ul style="list-style-type: none"> - Open Circuit - Short to VPwr - Short to 5V - Short to GND 				
Troubleshooting Steps					
1. With Ignition switch in OFF position, remove ECU power by pulling the ECU circuit breaker. Wait 10s before resetting. Is fault still active or repetitive? If yes, replace the ECU.					

Fault ID	203	Fault Group	26	Fault Name	<i>[FAULT: AN39 circuit]</i>
Fault Description	Primary/Secondary: Power Box Temperature Circuit Fault			Fault Lamp	TLO
Root Cause	This fault occurs if the Raw voltage observed on the input is outside the expected window defined by the calibratable Highest and Lowest Valid Raw voltage values. This does not distinguish between Open and Short Circuit Faults as any of the following failures would result in the Raw voltage outside the expected voltage window: <ul style="list-style-type: none"> - Open Circuit - Short to VPwr - Short to 5V - Short to GND 				
Troubleshooting Steps					
1. With Ignition switch in OFF position, remove ECU power by pulling the ECU circuit breaker. Wait 10s before resetting. Is fault still active or repetitive? If yes, replace the ECU.					

Fault ID	204	Fault Group	26	Fault Name	<i>[FAULT: AN37 circuit]</i>
Fault Description	Primary/Secondary: Power Box Temperature Circuit Fault			Fault Lamp	TLO
Root Cause	This fault occurs if the Raw voltage observed on the input is outside the expected window defined by the calibratable Highest and Lowest Valid Raw voltage values. This does not distinguish between Open and Short Circuit Faults as any of the following failures would result in the Raw voltage outside the expected voltage window: <ul style="list-style-type: none"> - Open Circuit - Short to VPwr - Short to 5V - Short to GND 				
Troubleshooting Steps					
1. With Ignition switch in OFF position, remove ECU power by pulling the ECU circuit breaker. Wait 10s before resetting. Is fault still active or repetitive? If yes, replace the ECU.					

Fault ID	205	Fault Group	26	Fault Name	<i>[FAULT: AN38 circuit]</i>
Fault Description	Primary/Secondary: Actuator Supply Voltage Monitor Circuit Fault			Fault Lamp	TLO
Root Cause	This fault occurs if the Raw voltage observed on the input is outside the expected window defined by the calibratable Highest and Lowest Valid Raw voltage values. This does not distinguish between Open and Short Circuit Faults as any of the following failures would result in the Raw voltage outside the expected voltage window: <ul style="list-style-type: none"> - Open Circuit - Short to VPwr - Short to 5V - Short to GND 				
Troubleshooting Steps					
1. With Ignition switch in OFF position, remove ECU power by pulling the ECU circuit breaker. Wait 10s before resetting. Is fault still active or repetitive? If yes, replace the Power Box.					

Fault ID	206	Fault Group	26	Fault Name	<i>-Reserved-</i>
Fault Description				Fault Lamp	TLO
Root Cause					
Troubleshooting Steps					

Fault ID	207	Fault Group	26	Fault Name	<i>-Reserved-</i>
Fault Description				Fault Lamp	TLO
Root Cause					
Troubleshooting Steps					

Fault ID	208	Fault Group	27	Fault Name	<i>[FAULT: exhaust gas temperature cyl 2 range]</i>
Fault Description	Primary: EGT2 Sensor Range Fault Secondary: -reserved-			Fault Lamp	None
Fault ID	209	Fault Group	27	Fault Name	<i>[FAULT: exhaust gas temperature cyl 4 range]</i>
Fault Description	Primary: EGT4 Sensor Range Fault Secondary: -reserved-			Fault Lamp	None
Fault ID	210	Fault Group	27	Fault Name	<i>[FAULT: exhaust gas temperature cyl 6 range]</i>
Fault Description	Primary: EGT6 Sensor Range Fault Secondary: -reserved-			Fault Lamp	None
Fault ID	211	Fault Group	27	Fault Name	<i>[FAULT: exhaust gas temperature cyl 8 range]</i>
Fault Description	Primary: EGT8 Sensor Range Fault Secondary: -reserved-			Fault Lamp	None
Fault ID	212	Fault Group	27	Fault Name	<i>[FAULT: exhaust gas temperature cyl 1 range]</i>
Fault Description	Primary: -reserved- Secondary: EGT1 Sensor Range Fault			Fault Lamp	None
Fault ID	213	Fault Group	27	Fault Name	<i>[FAULT: exhaust gas temperature cyl 3 range]</i>
Fault Description	Primary: -reserved- Secondary: EGT3 Sensor Range Fault			Fault Lamp	None
Fault ID	214	Fault Group	27	Fault Name	<i>[FAULT: exhaust gas temperature cyl 5 range]</i>
Fault Description	Primary: -reserved- Secondary: EGT5 Sensor Range Fault			Fault Lamp	None
Fault ID	215	Fault Group	27	Fault Name	<i>[FAULT: exhaust gas temperature cyl 7 range]</i>
Fault Description	Primary: -reserved- Secondary: EGT7 Sensor Range Fault			Fault Lamp	None
Root Cause	<p>This fault occurs if the Engineering value of the measured parameter is outside the expected window defined by the calibratable Highest and Lowest Valid Engineering Values.</p> <p>The Highest and Lowest possible engineering values define the range of values that can be expected for the entire engine operating envelope. Any value observed outside this envelope is flagged as a sensor range fault.</p>				
Troubleshooting Steps for Faults 208 thru 215					
<ol style="list-style-type: none"> Run the engine in accordance with the engine and aircraft maintenance manuals. Is the fault active? If yes, go to step 3. If no, go to step 2. Using the FST, download active and service fault logs, then clear fault logs and monitor engine operation for the fault to repeat. 					

Troubleshooting Steps for Faults 208 thru 215 (Cont.)

3. Inspect the sensor, sensor lead and connector. If there is damage found, replace the sensor per the “Sensor Replacement Procedure” in Chapter 72-70. If there is no damage, go to step 4.
4. Inspect engine harness for visible signs of damage. If damage is found, contact Lycoming Engines. If no damage is found, go to step 5.
5. Swap the sensor from the channel giving the fault with another sensor in a different position and run the engine. Did the fault move with the sensor? If yes, replace the sensor per the “Sensor Replacement Procedure” in Chapter 72-70. If no, complete a continuity test of the harness from the harness sensor connector to the ECU connector using the engine system schematic. If the continuity check fails, isolate to affected harness by disconnecting the firewall connection, then contact Lycoming Engines. If the continuity checks good, replace the ECU.
6. If the above steps are unsuccessful, contact Lycoming.

Fault ID	216	Fault Group	28	Fault Name	<i>[FAULT EGT 2 External Supply Fault]</i>
Fault Description	Primary: EGT2 External Reference Fault Secondary: -reserved-			Fault Lamp	None
Fault ID	217	Fault Group	28	Fault Name	<i>[FAULT EGT 4 External Supply Fault]</i>
Fault Description	Primary: EGT2 External Reference Fault Secondary: -reserved-			Fault Lamp	None
Fault ID	218	Fault Group	28	Fault Name	<i>[FAULT EGT 6 External Supply Fault]</i>
Fault Description	Primary: EGT2 External Reference Fault Secondary: -reserved-			Fault Lamp	None
Fault ID	219	Fault Group	28	Fault Name	<i>[FAULT EGT 8 External Supply Fault]</i>
Fault Description	Primary: EGT2 External Reference Fault Secondary: -reserved-			Fault Lamp	None
Fault ID	220	Fault Group	28	Fault Name	<i>[FAULT EGT 1 External Supply Fault]</i>
Fault Description	Primary -reserved- Secondary EGT1 External Reference Fault			Fault Lamp	None
Fault ID	221	Fault Group	28	Fault Name	<i>[FAULT EGT 3 External Supply Fault]</i>
Fault Description	Primary -reserved- Secondary EGT3 External Reference Fault			Fault Lamp	None
Fault ID	222	Fault Group	28	Fault Name	<i>[FAULT EGT 5 External Supply Fault]</i>
Fault Description	Primary -reserved- Secondary EGT5 External Reference Fault			Fault Lamp	None
Fault ID	223	Fault Group	28	Fault Name	<i>[FAULT EGT 7 External Supply Fault]</i>
Fault Description	Primary -reserved- Secondary EGT7 External Reference Fault			Fault Lamp	None
Root Cause	This fault occurs if there is a loss of the ACJ (Auto Cold Junction) in the ECU.				
Troubleshooting Steps					
<ol style="list-style-type: none"> 1. Is the fault active? If no, go to step 2. If yes, are there any other ACJ faults? If yes, go to troubleshooting procedure for corresponding fault. If no, replace the ECU. Then go to step 2. 2. Using the FST, download active and service fault logs, then clear fault logs and monitor engine operation for the fault to repeat. 					

Fault ID	224	Fault Group	29	Fault Name	<i>[FAULT: cylinder head temperature cyl 1 range]</i>
Fault Description	Primary: CHT1 Sensor Range Fault Secondary: -reserved-			Fault Lamp	TLO
Fault ID	225	Fault Group	29	Fault Name	<i>[FAULT: cylinder head temperature cyl 3 range]</i>
Fault Description	Primary: CHT3 Sensor Range Fault Secondary: -reserved-			Fault Lamp	TLO
Fault ID	226	Fault Group	29	Fault Name	<i>[FAULT: cylinder head temperature cyl 5 range]</i>
Fault Description	Primary: CHT5 Sensor Range Fault Secondary: -reserved-			Fault Lamp	TLO
Fault ID	227	Fault Group	29	Fault Name	<i>[FAULT: cylinder head temperature cyl 7 range]</i>
Fault Description	Primary: CHT7 Sensor Range Fault Secondary: -reserved-			Fault Lamp	TLO
Fault ID	228	Fault Group	29	Fault Name	<i>[FAULT: cylinder head temperature cyl 2 range]</i>
Fault Description	Primary: -reserved- Secondary: CHT2 Sensor Range Fault			Fault Lamp	TLO
Fault ID	229	Fault Group	29	Fault Name	<i>[FAULT: cylinder head temperature cyl 4 range]</i>
Fault Description	Primary: -reserved- Secondary: CHT4 Sensor Range Fault			Fault Lamp	TLO
Fault ID	230	Fault Group	29	Fault Name	<i>[FAULT: cylinder head temperature cyl 6 range]</i>
Fault Description	Primary: -reserved- Secondary: CHT6 Sensor Range Fault			Fault Lamp	TLO
Fault ID	231	Fault Group	29	Fault Name	<i>[FAULT: cylinder head temperature cyl 8 range]</i>
Fault Description	Primary: -reserved- Secondary: CHT8 Sensor Range Fault			Fault Lamp	TLO
Root Cause	This fault occurs if the Engineering value of the measured parameter is outside the expected window defined by the calibratable Highest and Lowest Valid Engineering Values. The Highest and Lowest possible engineering values define the range of values that can be expected for the entire engine operating envelope. Any value observed outside this envelope is flagged as a sensor range fault.				
Troubleshooting Steps for Faults 224 thru 231					
<ol style="list-style-type: none"> 1. Run the engine in accordance with the engine and aircraft maintenance manuals. Is the fault active? If yes, go to step 3. If no, go to step 2. 2. Using the FST, download active and service fault logs, then clear fault logs and monitor engine operation for the fault to repeat. 3. Inspect the sensor, sensor lead and connector. If there is damage found, replace the sensor per the "Sensor Replacement Procedure" in Chapter 72-70. If there is no damage, go to step 4. 4. Inspect engine harness for visible signs of damage. If damage is found, contact Lycoming Engines. If no damage is found, go to step 5. 5. Swap the sensor from the channel giving the fault with another sensor in a different position and run the engine. Did the fault move with the sensor? If yes, replace the sensor per the "Sensor Replacement Procedure" in Chapter 72-70. If no, complete a continuity test of the harness from the harness sensor connector to the ECU connector using the engine system schematic. If the continuity check fails, isolate to affected harness by disconnecting the firewall connection, then contact Lycoming Engines. If the continuity checks good, replace the ECU. 6. If the above steps are unsuccessful, contact Lycoming 					

Fault ID	232	Fault Group	30	Fault Name	<i>[FAULT CHT 1 External Supply Fault]</i>
Fault Description	Primary: CHT1 External Reference Fault Secondary: -reserved-			Fault Lamp	None
Fault ID	233	Fault Group	30	Fault Name	<i>[FAULT CHT 3 External Supply Fault]</i>
Fault Description	Primary: CHT3 External Reference Fault Secondary: -reserved-			Fault Lamp	None
Fault ID	234	Fault Group	30	Fault Name	<i>[FAULT CHT 5 External Supply Fault]</i>
Fault Description	Primary: CHT5 External Reference Fault Secondary: -reserved-			Fault Lamp	None
Fault ID	235	Fault Group	30	Fault Name	<i>[FAULT CHT 7 External Supply Fault]</i>
Fault Description	Primary: CHT7 External Reference Fault Secondary: -reserved-			Fault Lamp	None
Fault ID	236	Fault Group	30	Fault Name	<i>[FAULT CHT 2 External Supply Fault]</i>
Fault Description	Primary: -reserved- Secondary: CHT2 External Reference Fault			Fault Lamp	None
Fault ID	237	Fault Group	30	Fault Name	<i>[FAULT CHT 4 External Supply Fault]</i>
Fault Description	Primary: -reserved- Secondary: CHT4 External Reference Fault			Fault Lamp	None
Fault ID	238	Fault Group	30	Fault Name	<i>[FAULT CHT 6 External Supply Fault]</i>
Fault Description	Primary: -reserved- Secondary: CHT6 External Reference Fault			Fault Lamp	None
Fault ID	239	Fault Group	30	Fault Name	<i>[FAULT CHT 8 External Supply Fault]</i>
Fault Description	Primary: -reserved- Secondary: CHT8 External Reference Fault			Fault Lamp	None
Root Cause	This fault occurs if there is a loss of the ACJ (Auto Cold Junction) in the ECU.				
Troubleshooting Steps for Faults 232 thru 239					
<ol style="list-style-type: none"> 1. Is the fault active? If no, go to step 2. If yes, are there any other ACJ faults? If yes, go to troubleshooting procedure for corresponding fault. If no, replace the ECU. Then go to step 2. 2. Using the FST, download active and service fault logs, then clear fault logs and monitor engine operation for the fault to repeat. 					

Fault ID	240	Fault Group	31	Fault Name	<i>[FAULT: turbine inlet temperature 1 range]</i>
Fault Description	Primary: TIT1 Sensor Range Fault Secondary: -reserved-			Fault Lamp	TLO
Root Cause	This fault occurs if the Engineering value of the measured parameter is outside the expected window defined by the calibratable Highest and Lowest Valid Engineering Values. The Highest and Lowest possible engineering values define the range of values that can be expected for the entire engine operating envelope. Any value observed outside this envelope is flagged as a sensor range fault.				
Troubleshooting Steps					
<ol style="list-style-type: none"> 1. Run the engine in accordance with the engine and aircraft maintenance manuals. Is the fault active? If yes, go to step 3. If no, go to step 2. 2. Using the FST, download active and service fault logs, then clear fault logs and monitor engine operation for the fault to repeat. 3. Inspect the sensor, sensor lead and connector. If there is damage found, replace the sensor per the "Sensor Replacement Procedure" in Chapter 72-70. If there is no damage, go to step 4. 4. Inspect engine harness for visible signs of damage. If damage is found, contact Lycoming Engines. If no damage is found, go to step 5. 5. Swap the sensor from the channel giving the fault with another sensor in a different position (if equipped) and run the engine. Did the fault move with the sensor? If yes, replace the sensor per the "Sensor Replacement Procedure" in Chapter 72-70. If there is no sensor to swap with, replace the sensor. Did the fault clear? If no, complete a continuity test of the harness from the harness sensor connector to the ECU connector using the engine system schematic. If the continuity check fails, isolate to affected harness by disconnecting the firewall connection, then contact Lycoming Engines. If the continuity checks good, replace the ECU. 6. If the above steps are unsuccessful, contact Lycoming. 					
Fault ID	241	Fault Group	31	Fault Name	<i>[FAULT: local manifold temperature range]</i>
Fault Description	Primary: MAT Sensor Range Fault Secondary: MAT Sensor Range Fault			Fault Lamp	TLO
Root Cause	This fault occurs if the Engineering value of the measured parameter is outside the expected window defined by the calibratable Highest and Lowest Valid Engineering Values. The Highest and Lowest possible engineering values define the range of values that can be expected for the entire engine operating envelope. Any value observed outside this envelope is flagged as a sensor range fault.				
Troubleshooting Steps					
<ol style="list-style-type: none"> 1. Run the engine in accordance with the engine and aircraft maintenance manuals. Is the fault active? If yes, go to step 3. If no, go to step 2. 2. Using the FST, download active and service fault logs, then clear fault logs and monitor engine operation for the fault to repeat. 3. Inspect the sensor, sensor lead and connector. If there is damage found, replace the sensor per the "Sensor Replacement Procedure" in Chapter 72-70. If there is no damage, go to step 4. 4. Inspect engine harness for visible signs of damage. If damage is found, contact Lycoming Engines. If no damage is found, go to step 5. 5. Swap the sensor from the channel giving the fault with another sensor in a different position and run the engine. Did the fault move with the sensor? If yes, replace the sensor per the "Sensor Replacement Procedure" in Chapter 72-70. If no, complete a continuity test of the harness from the harness sensor connector to the ECU connector using the engine system schematic. If the continuity check fails, isolate to affected harness by disconnecting the firewall connection, then contact Lycoming Engines. If the continuity checks good, replace the ECU. 6. If the above steps are unsuccessful, contact Lycoming. 					

Fault ID	242	Fault Group	31	Fault Name	<i>[FAULT: deck temperature range]</i>
Fault Description	Primary: Deck Temperature Sensor Range Fault Secondary: -reserved-			Fault Lamp	TLO
Root Cause	This fault occurs if the Engineering value of the measured parameter is outside the expected window defined by the calibratable Highest and Lowest Valid Engineering Values. The Highest and Lowest possible engineering values define the range of values that can be expected for the entire engine operating envelope. Any value observed outside this envelope is flagged as a sensor range fault.				

Troubleshooting Steps

1. Run the engine in accordance with the engine and aircraft maintenance manuals. Is the fault active? If yes, go to step 3. If no, go to step 2.
2. Using the FST, download active and service fault logs, then clear fault logs and monitor engine operation for the fault to repeat.
3. Inspect the sensor, sensor lead and connector. If there is damage found, replace the sensor per the “Sensor Replacement Procedure” in Chapter 72-70. If there is no damage, go to step 4.
4. Inspect engine harness for visible signs of damage. If damage is found, contact Lycoming Engines. If no damage is found, go to step 5.
5. Swap the sensor from the channel giving the fault with another sensor in a different position and run the engine. Did the fault move with the sensor? If yes, replace the sensor per the “Sensor Replacement Procedure” in Chapter 72-70. If no, complete a continuity test of the harness from the harness sensor connector to the ECU connector using the engine system schematic. If the continuity check fails, isolate to affected harness by disconnecting the firewall connection, then contact Lycoming Engines. If the continuity checks good, replace the ECU.
6. If the above steps are unsuccessful, contact Lycoming

Fault ID	243	Fault Group	31	Fault Name	<i>[FAULT: fuel rail temperature range]</i>
Fault Description	Primary: FRT (Fuel Rail Temperature) Sensor Range Fault Secondary: -reserved-			Fault Lamp	TLO
Root Cause	This fault occurs if the Engineering value of the measured parameter is outside the expected window defined by the calibratable Highest and Lowest Valid Engineering Values. The Highest and Lowest possible engineering values define the range of values that can be expected for the entire engine operating envelope. Any value observed outside this envelope is flagged as a sensor range fault.				

Troubleshooting Steps

1. Run the engine in accordance with the engine and aircraft maintenance manuals. Is the fault active? If yes, go to step 3. If no, go to step 2.
2. Using the FST, download active and service fault logs, then clear fault logs and monitor engine operation for the fault to repeat.
3. Inspect the sensor, sensor lead and connector. If there is damage found, replace the sensor per the “Sensor Replacement Procedure” in Chapter 72-70. If there is no damage, go to step 4.
4. Inspect engine harness for visible signs of damage. If damage is found, contact Lycoming Engines. If no damage is found, go to step 5.
5. Swap the fuel rail temp sensor with the oil temperature sensor (A026) and run the engine. Is there now an active oil temperature sensor range fault? If yes, replace the sensor per the “Sensor Replacement Procedure” in Chapter 72-70. If no, complete a continuity test of the harness from the harness sensor connector to the ECU connector using the engine system schematic. If the continuity check fails, isolate to affected harness by disconnecting the firewall connection, then contact Lycoming Engines. If the continuity checks good, replace the ECU.
6. If the above steps are unsuccessful, contact Lycoming

Fault ID	244	Fault Group	31	Fault Name	<i>-Reserved-</i>
Fault Description				Fault Lamp	TLO
Root Cause					
Troubleshooting Steps					

Fault ID	245	Fault Group	31	Fault Name	<i>[FAULT: turbine inlet temperature 2 range]</i>
Fault Description	Primary: -reserved- Secondary: TIT2 Sensor Range Fault			Fault Lamp	TLO
Root Cause	This fault occurs if the Engineering value of the measured parameter is outside the expected window defined by the calibratable Highest and Lowest Valid Engineering Values. The Highest and Lowest possible engineering values define the range of values that can be expected for the entire engine operating envelope. Any value observed outside this envelope is flagged as a sensor range fault.				
Troubleshooting Steps					
<ol style="list-style-type: none"> 1. Run the engine in accordance with the engine and aircraft maintenance manuals. Is the fault active? If yes, go to step 3. If no, go to step 2. 2. Using the FST, download active and service fault logs, then clear fault logs and monitor engine operation for the fault to repeat. 3. Inspect the sensor, sensor lead and connector. If there is damage found, replace the sensor per the "Sensor Replacement Procedure" in Chapter 72-70. If there is no damage, go to step 4. 4. Inspect engine harness for visible signs of damage. If damage is found, contact Lycoming Engines. If no damage is found, go to step 5. 5. Swap the sensor from the channel giving the fault with another sensor in a different position (if equipped) and run the engine. Did the fault move with the sensor? If yes, replace the sensor per the "Sensor Replacement Procedure" in Chapter 72-70. If there is no sensor to swap with, replace the sensor. Did the fault clear? If no, complete a continuity test of the harness from the harness sensor connector to the ECU connector using the engine system schematic. If the continuity check fails, isolate to affected harness by disconnecting the firewall connection, then contact Lycoming Engines. If the continuity checks good, replace the ECU. 6. If the above steps are unsuccessful, contact Lycoming. 					

Fault ID	246	Fault Group	31	Fault Name	<i>-Reserved-</i>
Fault Description				Fault Lamp	TLO
Root Cause					
Troubleshooting Steps					

Fault ID	247	Fault Group	31	Fault Name	<i>[FAULT: engine oil temperature range]</i>
Fault Description	Primary -reserved- Secondary: EOT Sensor Range Fault			Fault Lamp	TLO
Root Cause	This fault occurs if the Engineering value of the measured parameter is outside the expected window defined by the calibratable Highest and Lowest Valid Engineering Values. The Highest and Lowest possible engineering values define the range of values that can be expected for the entire engine operating envelope. Any value observed outside this envelope is flagged as a sensor range fault.				
Troubleshooting Steps					
<ol style="list-style-type: none"> 1. Run the engine in accordance with the engine and aircraft maintenance manuals. Is the fault active? If yes, go to step 3. If no, go to step 2. 2. Using the FST, download active and service fault logs, then clear fault logs and monitor engine operation for the fault to repeat. 3. Inspect the sensor, sensor lead and connector. If there is damage found, replace the sensor per the “Sensor Replacement Procedure” in Chapter 72-70. If there is no damage, go to step 4. 4. Inspect engine harness for visible signs of damage. If damage is found, contact Lycoming Engines. If no damage is found, go to step 5. 5. Swap the oil temperature sensor with the fuel rail temp sensor (A012) and run the engine. Is there now an active fuel rail temp sensor range fault? If yes, replace the sensor per the “Sensor Replacement Procedure” in Chapter 72-70. If no, complete a continuity test of the harness from the harness sensor connector to the ECU connector using the engine system schematic. If the continuity check fails, isolate to affected harness by disconnecting the firewall connection, then contact Lycoming Engines. If the continuity checks good, replace the ECU. 6. If the above steps are unsuccessful, contact Lycoming. 					

Fault ID	248	Fault Group	32	Fault Name	<i>[FAULT: venturi pressure range]</i>
Fault Description	Primary: Venturi Pressure Sensor Range Fault Secondary: -reserved-			Fault Lamp	TLO
Root Cause	This fault occurs if the Engineering value of the measured parameter is outside the expected window defined by the calibratable Highest and Lowest Valid Engineering Values. The Highest and Lowest possible engineering values define the range of values that can be expected for the entire engine operating envelope. Any value observed outside this envelope is flagged as a sensor range fault.				
Troubleshooting Steps					
<ol style="list-style-type: none"> 1. Run the engine in accordance with the engine and aircraft maintenance manuals. Is the fault active? If yes, go to step 3. If no, go to step 2. 2. Using the FST, download active and service fault logs, then clear fault logs and monitor engine operation for the fault to repeat. 3. Inspect the sensor, and sensor connector. If there is damage found, replace the throttle body* per the “(Electronic Throttle Body Replacement” procedure in Chapter 73-20. If there is no damage, go to step 4. 4. Inspect engine harness for visible signs of damage. If damage is found, contact Lycoming Engines. If no damage is found, go to step 5. 5. Complete a continuity test of the harness from the harness sensor connector to the ECU connector using the engine system schematic. If the continuity check fails, isolate to affected harness by disconnecting the firewall connection, then contact Lycoming Engines. If the continuity checks good, go to step 6. 6. Replace the throttle body. Is the fault active? If yes, replace the ECU. 7. If the above steps are unsuccessful, contact Lycoming. <p>*NOTE: This sensor is a sub-part of throttle body assembly hence replacing the sensor is not possible and requires replacement of the entire throttle body assembly.</p>					

Fault ID	249	Fault Group	32	Fault Name	<i>[FAULT: local deck pressure range]</i>
Fault Description	Primary: Deck Pressure Sensor Range Fault Secondary: Deck Pressure Sensor Range Fault			Fault Lamp	TLO
Root Cause	This fault occurs if the Engineering value of the measured parameter is outside the expected window defined by the calibratable Highest and Lowest Valid Engineering Values. The Highest and Lowest possible engineering values define the range of values that can be expected for the entire engine operating envelope. Any value observed outside this envelope is flagged as a sensor range fault.				
Troubleshooting Steps					
<ol style="list-style-type: none"> 1. Run the engine in accordance with the engine and aircraft maintenance manuals. Is the fault active? If yes, go to step 3. If no, go to step 2. 2. Using the FST, download active and service fault logs, then clear fault logs and monitor engine operation for the fault to repeat. 3. Inspect the sensor, and sensor connector. If there is damage found, replace the sensor per the “Sensor Replacement Procedure” in Chapter 72-70. If there is no damage, go to step 4. 4. Inspect engine harness for visible signs of damage. If damage is found, contact Lycoming Engines. If no damage is found, go to step 5. 5. Swap the sensor from the channel giving the fault with another sensor in a different position (if equipped) and run the engine. Did the fault move with the sensor? If yes, replace the sensor per the “Sensor Replacement Procedure” in Chapter 72-70. If there is no sensor to swap with, replace the sensor. Did the fault clear? If no, complete a continuity test of the harness from the harness sensor connector to the ECU connector using the engine system schematic. If the continuity check fails, isolate to affected harness by disconnecting the firewall connection, then contact Lycoming Engines. If the continuity checks good, replace the ECU. 6. If the above steps are unsuccessful, contact Lycoming. 					

Fault ID	250	Fault Group	32	Fault Name	<i>[FAULT: local compressor inlet air pressure range]</i>
Fault Description	Primary: CIP Sensor Range Fault Secondary: CIP Sensor Range Fault		Fault Lamp	TLO	
Root Cause	This fault occurs if the Engineering value of the measured parameter is outside the expected window defined by the calibratable Highest and Lowest Valid Engineering Values. The Highest and Lowest possible engineering values define the range of values that can be expected for the entire engine operating envelope. Any value observed outside this envelope is flagged as a sensor range fault.				
Troubleshooting Steps					
<ol style="list-style-type: none"> 1. Run the engine in accordance with the engine and aircraft maintenance manuals. Is the fault active? If yes, go to step 3. If no, go to step 2. 2. Using the FST, download active and service fault logs, then clear fault logs and monitor engine operation for the fault to repeat. 3. Inspect the sensor, and sensor connector. If there is damage found, replace the sensor per the “Sensor Replacement Procedure” in Chapter 72-70. If there is no damage, go to step 4. 4. Inspect engine harness for visible signs of damage. If damage is found, contact Lycoming Engines. If no damage is found, go to step 5. 5. Swap the sensor from the channel giving the fault with another sensor in a different position (if equipped) and run the engine. Did the fault move with the sensor? If yes, replace the sensor per the “Sensor Replacement Procedure” in Chapter 72-70. If there is no sensor to swap with, replace the sensor. Did the fault clear? If no, complete a continuity test of the harness from the harness sensor connector to the ECU connector using the engine system schematic. If the continuity check fails, isolate to affected harness by disconnecting the firewall connection, then contact Lycoming Engines. If the continuity checks good, replace the ECU. 6. If the above steps are unsuccessful, contact Lycoming. 					

Fault ID	251	Fault Group	32	Fault Name	<i>[FAULT: engine oil pressure range]</i>
Fault Description	Primary: EOP Sensor Range Fault Secondary: -reserved-		Fault Lamp	TLO	
Root Cause	This fault occurs if the Engineering value of the measured parameter is outside the expected window defined by the calibratable Highest and Lowest Valid Engineering Values. The Highest and Lowest possible engineering values define the range of values that can be expected for the entire engine operating envelope. Any value observed outside this envelope is flagged as a sensor range fault.				
Troubleshooting Steps					
<ol style="list-style-type: none"> 1. Run the engine in accordance with the engine and aircraft maintenance manuals. Is the fault active? If yes, go to step 3. If no, go to step 2. 2. Using the FST, download active and service fault logs, then clear fault logs and monitor engine operation for the fault to repeat. 3. Inspect sensor, and lines for any damage (eg...burned, broken or frayed wires, cracked or broken connectors or hoses, burned or broken sensors). If damaged, replace the sensor per the “Sensor Replacement Procedure” in Chapter 72-70. If no damage is found, go to step 4. 4. Inspect harness connection for any damage (eg...burned, broken or frayed wires, cracked or broken connectors). Contact Lycoming if harness damage is found. If no damage found, replace the sensor. If fault is still active, go to step 5. 5. Complete a continuity test of the harness from the harness sensor connector to the ECU connector using the engine system schematic. If the continuity check fails, isolate to affected harness by disconnecting the firewall connection, then contact Lycoming Engines. If the continuity checks good and fault persists, replace the ECU. 					

Fault ID	252	Fault Group	32	Fault Name	<i>[FAULT: fuel rail pressure range]</i>
Fault Description	Primary: FRP Sensor Range Fault Secondary: -reserved-			Fault Lamp	TLO
Root Cause	This fault occurs if the Engineering value of the measured parameter is outside the expected window defined by the calibratable Highest and Lowest Valid Engineering Values. The Highest and Lowest possible engineering values define the range of values that can be expected for the entire engine operating envelope. Any value observed outside this envelope is flagged as a sensor range fault.				
Troubleshooting Steps					
<ol style="list-style-type: none"> 1. Run the engine in accordance with the engine and aircraft maintenance manuals. Is the fault active? If yes, go to step 3. If no, go to step 2. 2. Using the FST, download active and service fault logs, then clear fault logs and monitor engine operation for the fault to repeat. 3. Inspect sensor, and lines for any damage (eg...burned, broken or frayed wires, cracked or broken connectors or hoses, burned or broken sensors). If damage is found, replace the damaged part per the "Sensor Replacement Procedure" in Chapter 72-70. If no damage is found, go to step 4. 4. Inspect harness connection for any damage (eg...burned, broken or frayed wires, cracked or broken connectors). Contact Lycoming if harness damage is found. If no damage found, go to step 5. 5. Swap fuel rail pressure sensor with fuel pump pressure sensor and run the engine. Does the fault move with the sensor? If yes, replace the sensor. If no, go to step 6. 6. Complete a continuity test of the harness from the harness sensor connector to the ECU connector using the engine system schematic. If the continuity check fails, isolate to affected harness by disconnecting the firewall connection, then contact Lycoming Engines. If the continuity checks good, replace the sensor. If fault persists, replace the ECU. 					

Fault ID	253	Fault Group	32	Fault Name	<i>[FAULT: local throttle position range]</i>
Fault Description	Primary: TPS Sensor Range Fault Secondary: TPS Sensor Range Fault			Fault Lamp	TLO
Root Cause	This fault occurs if the Engineering value of the measured parameter is outside the expected window defined by the calibratable Highest and Lowest Valid Engineering Values. The Highest and Lowest possible engineering values define the range of values that can be expected for the entire engine operating envelope. Any value observed outside this envelope is flagged as a sensor range fault.				
Troubleshooting Steps					
<ol style="list-style-type: none"> 1. Run the engine in accordance with the engine and aircraft maintenance manuals. Is the fault active? If yes, go to step 3. If no, go to step 2. 2. Using the FST, download active and service fault logs, then clear fault logs and monitor engine operation for the fault to repeat. 3. Inspect the sensor, sensor connector. If there is damage found, replace the throttle body* per the "(Electronic) Throttle Body Replacement" procedure in Chapter 73-20. If there is no damage, go to step 4. 4. Inspect engine harness for visible signs of damage. If damage is found, contact Lycoming Engines. If no damage is found, go to step 5. 5. Complete a continuity test of the harness from the harness sensor connector to the ECU connector using the engine system schematic. If the continuity check fails, isolate to affected harness by disconnecting the firewall connection, then contact Lycoming Engines. If the continuity checks good, go to step 6. 6. Replace the throttle body. Is the fault active? If yes, replace the ECU. 7. If the above steps are unsuccessful, contact Lycoming <p>*NOTE: This sensor is a sub-part of throttle body assembly hence replacing the sensor is not possible and requires replacement of the entire throttle body assembly.</p>					

Fault ID	254	Fault Group	32	Fault Name	<i>[FAULT: manifold pressure range]</i>
Fault Description	Primary: -reserved- Secondary: MAP (Manifold Absolute Pressure) Range Fault			Fault Lamp	TLO
Root Cause	This fault occurs if the Engineering value of the measured parameter is outside the expected window defined by the calibratable Highest and Lowest Valid Engineering Values. The Highest and Lowest possible engineering values define the range of values that can be expected for the entire engine operating envelope. Any value observed outside this envelope is flagged as a sensor range fault.				
Troubleshooting Steps					
<ol style="list-style-type: none"> 1. Run the engine in accordance with the engine and aircraft maintenance manuals. Is the fault active? If yes, go to step 3. If no, go to step 2. 2. Using the FST, download active and service fault logs, then clear fault logs and monitor engine operation for the fault to repeat. 3. Inspect sensor, and lines for any damage (eg...burned, broken or frayed wires, cracked or broken connectors or hoses, burned or broken sensors). If damaged, replace the sensor per the "Sensor Replacement Procedure" in Chapter 72-70. If no damage is found, go to step 4. 4. Inspect harness connection for any damage (eg...burned, broken or frayed wires, cracked or broken connectors). Contact Lycoming if harness damage is found. If no damage found, replace the sensor. If fault is still active, go to step 5. 5. Complete a continuity test of the harness from the harness sensor connector to the ECU connector using the engine system schematic. If the continuity check fails, isolate to affected harness by disconnecting the firewall connection, then contact Lycoming Engines. If the continuity checks good, and if fault persists, replace the ECU. 					

Fault ID	255	Fault Group	32	Fault Name	<i>[FAULT: fuel pump pressure range]</i>
Fault Description	Primary: -reserved- Secondary: FPP Sensor Range Fault			Fault Lamp	TLO
Root Cause	This fault occurs if the Engineering value of the measured parameter is outside the expected window defined by the calibratable Highest and Lowest Valid Engineering Values. The Highest and Lowest possible engineering values define the range of values that can be expected for the entire engine operating envelope. Any value observed outside this envelope is flagged as a sensor range fault.				
Troubleshooting Steps					
<ol style="list-style-type: none"> 1. Run the engine in accordance with the engine and aircraft maintenance manuals. Is the fault active? If yes, go to step 3. If no, go to step 2. 2. Using the FST, download active and service fault logs, then clear fault logs and monitor engine operation for the fault to repeat. 3. Inspect sensor, and lines for any damage (eg...burned, broken or frayed wires, cracked or broken connectors or hoses, burned or broken sensors). If damage is found, replace the damaged part per the "Sensor Replacement Procedure" in Chapter 72-70. If no damage is found, go to step 4. 4. Inspect harness connection for any damage (eg...burned, broken or frayed wires, cracked or broken connectors). Contact Lycoming if harness damage is found. If no damage found, go to step 5. 5. Swap fuel rail pressure sensor with fuel pump pressure sensor and run the engine. Does the fault move with the sensor? If yes, replace the sensor. If no, go to step 6. 6. Complete a continuity test of the harness from the harness sensor connector to the ECU connector using the engine system schematic. If the continuity check fails, isolate to affected harness by disconnecting the firewall connection, then contact Lycoming Engines. If the continuity checks good, replace the sensor. If fault persists, replace the ECU. 					

Fault ID	256	Fault Group	33	Fault Name	<i>[FAULT: analogue engine identifier range]</i>
Fault Description	Primary: -reserved- Secondary: Engine ID Sensor Range Fault			Fault Lamp	TLO
Root Cause	This fault occurs if the Engineering value of the measured parameter is outside the expected window defined by the calibratable Highest and Lowest Valid Engineering Values. The Highest and Lowest possible engineering values define the range of values that can be expected for the entire engine operating envelope. Any value observed outside this envelope is flagged as a sensor range fault.				
Troubleshooting Steps					
<ol style="list-style-type: none"> 1. Run the engine in accordance with the engine and aircraft maintenance manuals. Is the fault active? If yes, go to step 2. If no, go to step 4. 2. With Ignition switch in OFF position, remove ECU power by pulling the ECU circuit breaker. Wait 10s before resetting. Is fault still active? If yes, go to step 3. If no, monitor engine operation for the fault to repeat. 3. Remove harness connector A001-P2 from ECU connector A001-J2. Using a multi-meter, check for continuity (or a specific resistance if a resistor is installed) between pins 33 and 42 of A001-P2. Does continuity (or correct resistance) exist? If yes, reconnect A001-J2, and go to step 4. If no, contact Lycoming Engines. 4. Clear Service fault history and start engine. If the fault is still active replace the ECU. <p>NOTE: By default, this configurable parameter has been disabled hence this fault should only occur if this is enabled in the calibration for an engine specific installation.</p>					

Fault ID	257	Fault Group	33	Fault Name	<i>[FAULT: analogue pilot operating mode range]</i>												
Fault Description	Primary: -reserved- Secondary: Op Mode Selector Sensor Range Fault			Fault Lamp	TLO												
Root Cause	This fault occurs if the Engineering value of the measured parameter is outside the expected window defined by the calibratable Highest and Lowest Valid Engineering Values. The Highest and Lowest possible engineering values define the range of values that can be expected for the entire engine operating envelope. Any value observed outside this envelope is flagged as a sensor range fault.																
Troubleshooting Steps																	
<ol style="list-style-type: none"> 1. Is there an active fault(s) that correspond to the fault numbers listed in the Root Cause box, items 1 and 2? If yes, go to troubleshooting procedure for the active fault(s). If no, go to step 2. 2. Inspect wires and resistors connected to switch for breaks or damage. Are wires or resistors broken or damaged? If yes, repair in accordance with the aircraft maintenance manual. If no, go to step 3. 3. Disconnect wires from switch and disconnect ECU connector A001-P2. Measure resistance from A001-P2 pin 48 to each wire and check for resistance as shown in the table below. Are the resistances measured within the table limits? If yes, go to step 4. If no, but resistance is present and not within table limits, replace the defective resistor in accordance with the aircraft maintenance manual. If no, and circuit is open, go to step 5. <table border="1" data-bbox="321 1705 976 1850"> <thead> <tr> <th>Switch Position</th> <th>Resistance</th> <th>Tolerance</th> </tr> </thead> <tbody> <tr> <td>C</td> <td>330kΩ</td> <td>±10%</td> </tr> <tr> <td>NORM</td> <td>1.01MΩ</td> <td>±10%</td> </tr> <tr> <td>S</td> <td>3.21MΩ</td> <td>±10%</td> </tr> </tbody> </table>						Switch Position	Resistance	Tolerance	C	330kΩ	±10%	NORM	1.01MΩ	±10%	S	3.21MΩ	±10%
Switch Position	Resistance	Tolerance															
C	330kΩ	±10%															
NORM	1.01MΩ	±10%															
S	3.21MΩ	±10%															

Troubleshooting Steps (Cont.)

4. Complete a continuity and short circuit test of the switch. If the continuity or short circuit check fails, replace the switch. If the continuity check is good, replace the ECU.
5. Complete a continuity test of the harness from the input side of each resistor to the ECU connector using the engine system schematic. If the continuity check fails, isolate to affected harness by disconnecting the airframe interface connection AF-P1. If the continuity fails between switch and AF-J1, repair cable in accordance with aircraft maintenance manual. If the continuity fails between AF-P1 and ECU, contact Lycoming Engines. If the continuity checks good, replace the ECU.

Fault ID	258	Fault Group	33	Fault Name	<i>[FAULT: ACJ temperature range]</i>
Fault Description	Primary: ACJ Temperature Sensor Range Fault Secondary: ACJ Temperature Sensor Range Fault		Fault Lamp	TLO	
Root Cause	This fault occurs if the Engineering value of the measured parameter is outside the expected window defined by the calibratable Highest and Lowest Valid Engineering Values. The Highest and Lowest possible engineering values define the range of values that can be expected for the entire engine operating envelope. Any value observed outside this envelope is flagged as a sensor range fault.				
Troubleshooting Steps					
<ol style="list-style-type: none"> 1. With Ignition switch in OFF position, remove ECU power by pulling the ECU circuit breaker. Wait 10s before resetting. Is fault still active or repetitive? If yes, go to step 2. If no, monitor engine operation for the fault to repeat. If fault repeats, go to step 2. 2. Check area surrounding ECU and Power Box to ensure there is nothing that could be causing an out of limit temperature change. If something is found, correct discrepancy. If nothing is found, go to step 3. 3. If fault is still active or repetitive, but is not affecting engine operation, contact Lycoming for further assistance. If fault affects engine operation (ie... causes other faults), replace the ECU. 					

Fault ID	259	Fault Group	33	Fault Name	<i>[FAULT: thermocouple offset voltage range]</i>
Fault Description	Primary: Thermocouple Offset Sensor Range Fault Secondary: Thermocouple Offset Sensor Range Fault		Fault Lamp	TLO	
Root Cause	This fault occurs if the Engineering value of the measured parameter is outside the expected window defined by the calibratable Highest and Lowest Valid Engineering Values. The Highest and Lowest possible engineering values define the range of values that can be expected for the entire engine operating envelope. Any value observed outside this envelope is flagged as a sensor range fault.				
Troubleshooting Steps					
<ol style="list-style-type: none"> 1. With Ignition switch in OFF position, remove ECU power by pulling the ECU circuit breaker. Wait 10s before resetting. Is fault active? If no, go to step 3. If yes, are there any other active EGT or CHT faults? If yes, go to corresponding troubleshooting procedure for the active fault. 2. Clear Service faults using the FST by following the steps outlined in the "Access the Field Service Tool" section in Appendix C or the latest revision of <i>SSP-118</i>. 3. If fault repeats, replace the ECU. 					

Fault ID	260	Fault Group	33	Fault Name	<i>[FAULT: ECU temperature range]</i>
Fault Description	Primary: ECU Temperature Sensor Range Fault Secondary: ECU Temperature Sensor Range Fault		Fault Lamp	TLO	
Root Cause	This fault occurs if the Engineering value of the measured parameter is outside the expected window defined by the calibratable Highest and Lowest Valid Engineering Values. The Highest and Lowest possible engineering values define the range of values that can be expected for the entire engine operating envelope. Any value observed outside this envelope is flagged as a sensor range fault.				
Troubleshooting Steps					
<ol style="list-style-type: none"> 1. With Ignition switch in OFF position, remove ECU power by pulling the ECU circuit breaker. Wait 10s before resetting. Is fault still active or repetitive? If yes, go to step 2. If no, monitor engine operation for the fault to repeat. If fault repeats, go to step 2. 2. Check area surrounding ECU and Power Box to ensure there is nothing that could be causing an out of limit temperature. If something is found, correct discrepancy, then go to step 4. If nothing is found, go to step 3. 3. If fault is still active or repetitive, but is not affecting engine operation, contact Lycoming for further assistance. If fault affects engine operation (ie... causes other faults), replace the ECU. 4. Clear Service faults using the FST by following the steps outlined in the "Access the Field Service Tool" section in Appendix C or the latest revision of <i>SSP-118</i>. 					

Fault ID	261	Fault Group	33	Fault Name	<i>[FAULT: APU-100 temperature range]</i>
Fault Description	Primary: Power Box Temperature Sensor Range Fault Secondary: Power Box Temperature Sensor Range Fault		Fault Lamp	TLO	
Root Cause	This fault occurs if the Engineering value of the measured parameter is outside the expected window defined by the calibratable Highest and Lowest Valid Engineering Values. The Highest and Lowest possible engineering values define the range of values that can be expected for the entire engine operating envelope. Any value observed outside this envelope is flagged as a sensor range fault.				
Troubleshooting Steps					
<ol style="list-style-type: none"> 1. With Ignition switch in OFF position, remove ECU power by pulling the ECU circuit breaker. Wait 10s before resetting. Is fault still active or repetitive? If yes, go to step 2. If no, monitor engine operation for the fault to repeat. If fault repeats, go to step 2. 2. Check area surrounding ECU and Power Box to ensure there is nothing that could be causing an out of limit temperature. If something is found, correct discrepancy, then go to step 4. If nothing is found, go to step 3. 3. If fault is still active or repetitive, but is not affecting engine operation, contact Lycoming for further assistance. If fault affects engine operation (ie... causes other faults), replace the Power Box, then go to step 4. 4. Clear Service faults using the FST by following the steps outlined in the "Access the Field Service Tool" section in Appendix C or the latest revision of <i>SSP-118</i>. 					

Fault ID	262	Fault Group	33	Fault Name	<i>-Reserved-</i>
Fault Description				Fault Lamp	TLO
Root Cause					
Troubleshooting Steps					

Fault ID	263	Fault Group	33	Fault Name	<i>-Reserved-</i>
Fault Description				Fault Lamp	TLO
Root Cause					
Troubleshooting Steps					

Fault ID	264	Fault Group	34	Fault Name	<i>[FAULT: 5V sensor supply 1 range]</i>
Fault Description	Primary: 5V Sensor Supply 1 Range Fault Secondary: 5V Sensor Supply 1 Range Fault			Fault Lamp	TLO
Fault ID	265	Fault Group	34	Fault Name	<i>[FAULT: 5V sensor supply 2 range]</i>
Fault Description	Primary: 5V Sensor Supply 2 Range Fault Secondary: 5V Sensor Supply 2 Range Fault			Fault Lamp	TLO
Root Cause	This fault occurs if the Engineering value of the measured parameter is outside the expected window defined by the calibratable Highest and Lowest Valid Engineering Values. The Highest and Lowest possible engineering values define the range of values that can be expected for the entire engine operating envelope. Any value observed outside this envelope is flagged as a sensor range fault.				
Troubleshooting Steps for Faults 264 and 265					
<ol style="list-style-type: none"> With Ignition switch in OFF position, remove ECU power by pulling the ECU circuit breaker. Wait 10s before resetting. Is fault active or intermittent? If active, and won't clear, replace the ECU. If intermittent, go to step 2. If not active or intermittent, monitor engine operation for the fault to repeat. If fault repeats, go to step 2. Inspect area around ECU, Power Box, ADL, and engine system cabling. Are there any RF or electrical cables within 6" of any of these that carry the following frequency ranges*? <ul style="list-style-type: none"> • 57Mhz (Supply 1) • 316Mhz (Supply 2) • 363Mhz (Supply 2) • 59Mhz (Supply 1) • 323Mhz (Supply 2) • 380Mhz (Supply 1) • 64Mhz (Supply 1) • 338Mhz (Supply 2) • 389Mhz (Supply 1) • 68Mhz (Supply 1) • 346Mhz (Supply 2) • 398Mhz (Supply 1) If yes, move cables so they are no longer within 6" of these components. <p>*NOTE: During RF Susceptibility testing, some frequencies in the ranges shown above were noted to cause an intermittent range fault by altering the 5V supply voltage to 0.001 volts below its engineering limit. This does not affect system operation, but, if the frequency is not removed, can produce an ongoing nuisance fault.</p>					

Fault ID	266	Fault Group	34	Fault Name	<i>[FAULT: 5V sensor supply 3 range]</i>
Fault Description	Primary: 5V Sensor Supply 3 Range Fault Secondary: 5V Sensor Supply 3 Range Fault		Fault Lamp	TLO	
Root Cause	This fault occurs if the Engineering value of the measured parameter is outside the expected window defined by the calibratable Highest and Lowest Valid Engineering Values. The Highest and Lowest possible engineering values define the range of values that can be expected for the entire engine operating envelope. Any value observed outside this envelope is flagged as a sensor range fault.				
Troubleshooting Steps					
<ol style="list-style-type: none"> 1. With Ignition switch in OFF position, remove ECU power by pulling the ECU circuit breaker. Wait 10s before resetting. Is fault active or intermittent? If active, and won't clear, replace the ECU. If intermittent, go to step 2. If not active or intermittent, monitor engine operation for the fault to repeat. If fault repeats, go to step 2. 2. Inspect area around ECU, Power Box, ADL, and engine system cabling. Are there any RF or electrical cables within 6" of any of these that carry the following frequency ranges*? <ul style="list-style-type: none"> • 38Mhz If yes, move cables so they are no longer within 6" of these components. <p>*NOTE: During RF Susceptibility testing, some frequencies in the ranges shown above were noted to cause an intermittent range fault by altering the 5V supply voltage to 0.001 volts below its monitored range. This does not affect system operation, but, if the frequency is not removed, can produce an ongoing nuisance fault.</p>					

Fault ID	267	Fault Group	34	Fault Name	<i>[FAULT: ECU supply voltage range]</i>
Fault Description	Primary: ECU Supply Voltage Range Fault Secondary: ECU Supply Voltage Range Fault		Fault Lamp	TLO	
Root Cause	This fault occurs if the Engineering value of the measured parameter is outside the expected window defined by the calibratable Highest and Lowest Valid Engineering Values. The Highest and Lowest possible engineering values define the range of values that can be expected for the entire engine operating envelope. Any value observed outside this envelope is flagged as a sensor range fault.				
Troubleshooting Steps					
<p>*NOTE: If the fault occurs prior to engine start (captured as RPM=0000 when the fault is logged.) Check the battery voltage before proceeding to Step 1. Refer to the aircraft maintenance manual, POH, or other aircraft manual for minimum battery voltage. If no voltage is stated, minimum voltage is 10.5 VDC. If the battery output voltage is less than the minimum, charge the battery or replace as necessary.</p> <ol style="list-style-type: none"> 1. With Ignition switch in OFF position, remove ECU power by pulling the ECU circuit breaker. Wait 10s before resetting. Is fault active? If no, go to step 2. If yes, replace the Power Box. 2. Clear Service faults using the FST by following the steps outlined in the "Access the Field Service Tool" section in Appendix C or the latest revision of <i>SSP-118</i>. 3. If fault repeats, replace the Power Box. 					

Fault ID	268	Fault Group	34	Fault Name	<i>[FAULT: actuator supply voltage range]</i>
Fault Description	Primary: Actuator Supply Voltage Range Fault Secondary: Actuator Supply Voltage Range Fault		Fault Lamp	TLO	
Root Cause	This fault occurs if the Engineering value of the measured parameter is outside the expected window defined by the calibratable Highest and Lowest Valid Engineering Values. The Highest and Lowest possible engineering values define the range of values that can be expected for the entire engine operating envelope. Any value observed outside this envelope is flagged as a sensor range fault.				
Troubleshooting Steps					
<ol style="list-style-type: none"> 1. With Ignition switch in OFF position, remove ECU power by pulling the ECU circuit breaker. Wait 10s before resetting. Is fault active? If no, go to step 2. If yes, replace the Power Box. 2. Clear Service faults using the FST by following the steps outlined in the “Access the Field Service Tool” section in Appendix C or the latest revision of <i>SSP-118</i>. 3. If fault repeats, replace the Power Box. 					

Fault ID	269	Fault Group	34	Fault Name	<i>-Reserved-</i>
Fault Description			Fault Lamp	TLO	
Root Cause					
Troubleshooting Steps					

Fault ID	270	Fault Group	34	Fault Name	<i>-Reserved-</i>
Fault Description			Fault Lamp	TLO	
Root Cause					
Troubleshooting Steps					

Fault ID	271	Fault Group	34	Fault Name	<i>-Reserved-</i>
Fault Description			Fault Lamp	TLO	
Root Cause					
Troubleshooting Steps					

Fault ID	272	Fault Group	35	Fault Name	[FAULT: venturi pressure external]
Fault Description	Primary: Venturi Pressure External (Sensor Supply Fault) Secondary: -reserved-		Fault Lamp	TLO	
Root Cause	<p>This fault implies that the 5V sensor supply that is connected to the sensor is deemed INVALID.</p> <p>1: The 5V supply may be INVALID due to a circuit fault or a slew-rate fault on the 5V supply. For details of the 5V Supply faults refer to Fault Ids 160-162, 196-198 and 264-266.</p> <p>2: Multiple sensors may be connected to the same 5V supply so if it becomes INVALID then all the sensors that are connected to it would set corresponding External (sensor supply) faults. Refer to the system schematic to identify the sensors that may be connected to a 5V supply.</p>				
Troubleshooting Steps					
<ol style="list-style-type: none"> 1. Is there an active fault(s) that correspond to the fault numbers listed in the Root Cause box, items 1 and 2? If yes, go to troubleshooting procedure for the active fault(s). If no, go to step 2. 2. With the ECU powered on, use a multi-meter to measure the voltage at the sensor connector A039-P pin B (5V supply) and pin A (GND). Is 5V present on pin B? If yes, replace the sensor. If no, go to step 3. 3. Inspect engine harness for visible signs of damage. If damage is found, contact Lycoming Engines. If no damage is found, go to step 4. 4. Complete a continuity test of the harness from the harness sensor connector A039-P to the ECU connector using the engine system schematic. If the continuity check fails, isolate to affected harness by disconnecting the firewall connection, then contact Lycoming Engines. If the continuity checks good, replace the ECU. 					
Fault ID	273	Fault Group	35	Fault Name	[FAULT: local deck pressure external]
Fault Description	Primary: Deck Pressure External (Sensor Supply Fault) Secondary: Deck Pressure External (Sensor Supply Fault)		Fault Lamp	TLO	
Root Cause	<p>This fault implies that the 5V sensor supply that is connected to the sensor is deemed INVALID.</p> <p>1: The 5V supply may be INVALID due to a circuit fault or a slew-rate fault on the 5V supply. For details of the 5V Supply faults refer to Fault Ids 160-162, 196-198 and 264-266.</p> <p>2: Multiple sensors may be connected to the same 5V supply so if it becomes INVALID then all the sensors that are connected to it would set corresponding External (sensor supply) faults. Refer to the system schematic to identify the sensors that may be connected to a 5V supply.</p>				
Troubleshooting Steps					
<ol style="list-style-type: none"> 1. Is there an active fault(s) that correspond to the fault numbers listed in the Root Cause box, items 1 and 2? If yes, go to troubleshooting procedure for the active fault(s). If no, go to step 2. 2. With the ECU powered on, use a multi-meter to measure the voltage at the sensor connector A045-P (Primary) or A036 (Secondary) pin C (5V supply) and pin A (GND). Is 5V present on pin C? If yes, replace the sensor. If no, go to step 3. 3. Inspect engine harness for visible signs of damage. If damage is found, contact Lycoming Engines. If no damage is found, go to step 4. 4. Complete a continuity test of the harness from the harness sensor connector A045-P or A036-P to the ECU connector using the engine system schematic. If the continuity check fails, isolate to affected harness by disconnecting the firewall connection, then contact Lycoming Engines. If the continuity checks good, replace the ECU. 					

Fault ID	274	Fault Group	35	Fault Name	<i>[FAULT: local compressor inlet air pressure external]</i>
Fault Description	Primary: CIP External (Sensor Supply Fault) Secondary: CIP External (Sensor Supply Fault)		Fault Lamp	TLO	
Root Cause	This fault implies that the 5V sensor supply that is connected to the sensor is deemed INVALID. 1: The 5V supply may be INVALID due to a circuit fault or a slew-rate fault on the 5V supply. For details of the 5V Supply faults refer to Fault Ids 160-162, 196-198 and 264-266. 2: Multiple sensors may be connected to the same 5V supply so if it becomes INVALID then all the sensors that are connected to it would set corresponding External (sensor supply) faults. Refer to the system schematic to identify the sensors that may be connected to a 5V supply.				
Troubleshooting Steps					
<ol style="list-style-type: none"> 1. Is there an active fault(s) that correspond to the fault numbers listed in the Root Cause box, items 1 and 2? If yes, go to troubleshooting procedure for the active fault(s). If no, go to step 2. 2. With the ECU powered on, use a multi-meter to measure the voltage at the sensor connector A037-P (Primary) or A038 (Secondary) pin C (5V supply) and pin A (GND). Is 5V present on pin C? If yes, replace the sensor. If no, go to step 3. 3. Inspect engine harness for visible signs of damage. If damage is found, contact Lycoming Engines. If no damage is found, go to step 4. 4. Complete a continuity test of the harness from the harness sensor connector A037-P or A038-P to the ECU connector using the engine system schematic. If the continuity check fails, isolate to affected harness by disconnecting the firewall connection, then contact Lycoming Engines. If the continuity checks good, replace the ECU. 					

Fault ID	275	Fault Group	35	Fault Name	<i>[FAULT: engine oil pressure external]</i>
Fault Description	Primary: EOP External (Sensor Supply Fault) Secondary -reserved-		Fault Lamp	TLO	
Root Cause	This fault implies that the 5V sensor supply that is connected to the sensor is deemed INVALID. 1: The 5V supply may be INVALID due to a circuit fault or a slew-rate fault on the 5V supply. For details of the 5V Supply faults refer to Fault Ids 160-162, 196-198 and 264-266. 2: Multiple sensors may be connected to the same 5V supply so if it becomes INVALID then all the sensors that are connected to it would set corresponding External (sensor supply) faults. Refer to the system schematic to identify the sensors that may be connected to a 5V supply.				
Troubleshooting Steps					
<ol style="list-style-type: none"> 1. Is there an active fault(s) that correspond to the fault numbers listed in the Root Cause box, items 1 and 2? If yes, go to troubleshooting procedure for the active fault(s). If no, go to step 2. 2. With the ECU powered on, use a multi-meter to measure the voltage at the sensor connector A025-P pin B (5V supply) and pin A (GND). Is 5V present on pin B? If yes, replace the sensor. If no, go to step 3. 3. Inspect engine harness for visible signs of damage. If damage is found, contact Lycoming Engines. If no damage is found, go to step 4. 4. Complete a continuity test of the harness from the harness sensor connector A025-P to the ECU connector using the engine system schematic. If the continuity check fails, isolate to affected harness by disconnecting the firewall connection, then contact Lycoming Engines. If the continuity checks good, replace the ECU. 					

Fault ID	276	Fault Group	35	Fault Name	<i>[FAULT: fuel rail pressure external]</i>
Fault Description	Primary: FRP External (Sensor Supply Fault) Secondary: -reserved-			Fault Lamp	TLO
Root Cause	<p>This fault implies that the 5V sensor supply that is connected to the sensor is deemed INVALID.</p> <p>1: The 5V supply may be INVALID due to a circuit fault or a slew-rate fault on the 5V supply. For details of the 5V Supply faults refer to Fault Ids 160-162, 196-198 and 264-266.</p> <p>2: Multiple sensors may be connected to the same 5V supply so if it becomes INVALID then all the sensors that are connected to it would set corresponding External (sensor supply) faults. Refer to the system schematic to identify the sensors that may be connected to a 5V supply.</p>				
Troubleshooting Steps					
<ol style="list-style-type: none"> 1. Is there an active fault(s) that correspond to the fault numbers listed in the Root Cause box, items 1 and 2? If yes, go to troubleshooting procedure for the active fault(s). If no, go to step 2. 2. With the ECU powered on, use a multi-meter to measure the voltage at the sensor connector A013-P pin B (5V supply) and pin A (GND). Is 5V present on pin B? If yes, replace sensor. If no, go to step 3. 3. Inspect engine harness for visible signs of damage. If damage is found, contact Lycoming Engines. If no damage is found, go to step 4. 4. Complete a continuity test of the harness from the harness sensor connector A013-P to the ECU connector using the engine system schematic. If continuity check fails, isolate to affected harness by disconnecting the firewall connection, then contact Lycoming Engines. If continuity checks good, replace the ECU. 					

Fault ID	277	Fault Group	35	Fault Name	<i>[FAULT: local throttle position external]</i>
Fault Description	Primary: TPS External (Sensor Supply Fault) Secondary: TPS External (Sensor Supply Fault)			Fault Lamp	TLO
Root Cause	<p>This fault implies that the 5V sensor supply that is connected to the sensor is deemed INVALID.</p> <p>1: The 5V supply may be INVALID due to a circuit fault or a slew-rate fault on the 5V supply. For details of the 5V Supply faults refer to Fault Ids 160-162, 196-198 and 264-266.</p> <p>2: Multiple sensors may be connected to the same 5V supply so if it becomes INVALID then all the sensors that are connected to it would set corresponding External (sensor supply) faults. Refer to the system schematic to identify the sensors that may be connected to a 5V supply.</p>				
Troubleshooting Steps					
<ol style="list-style-type: none"> 1. Is there an active fault(s) that correspond to the fault numbers listed in the Root Cause box, items 1 and 2? If yes, go to troubleshooting procedure for the active fault(s). If no, go to step 2. 2. With the ECU powered on, use a multi-meter to measure the voltage at the sensor connector A043-P pin E (5V supply Primary) and pin F (GND Primary) and pin B (5V supply Secondary) and pin A (GND Secondary). Is 5V present on pin E and B? If yes, replace the sensor. If no, go to step 3. 3. Inspect engine harness for visible signs of damage. If damage is found, contact Lycoming Engines. If no damage is found, go to step 4. 4. Complete a continuity test of the harness from the harness sensor connector A043-P to the ECU connector using the engine system schematic. If the continuity check fails, isolate to affected harness by disconnecting the firewall connection, then contact Lycoming Engines. If the continuity checks good, replace the ECU. 					

Fault ID	278	Fault Group	35	Fault Name	<i>[FAULT: manifold pressure external]</i>
Fault Description	Primary: -reserved- Secondary: MAP External (Sensor Supply Fault)			Fault Lamp	TLO
Root Cause	This fault implies that the 5V sensor supply that is connected to the sensor is deemed INVALID. 1: The 5V supply may be INVALID due to a circuit fault or a slew-rate fault on the 5V supply. For details of the 5V Supply faults refer to Fault Ids 160-162, 196-198 and 264-266. 2: Multiple sensors may be connected to the same 5V supply so if it becomes INVALID then all the sensors that are connected to it would set corresponding External (sensor supply) faults. Refer to the system schematic to identify the sensors that may be connected to a 5V supply.				
Troubleshooting Steps					
1. Is there an active fault(s) that correspond to the fault numbers listed in the Root Cause box, items 1 and 2? If yes, go to troubleshooting procedure for the active fault(s). If no, go to step 2. 2. With the ECU powered on, use a multi-meter to measure the voltage at the sensor connector A040-P pin B (5V supply) and pin A (GND). Is 5V present on pin B? If yes, replace the sensor. If no, go to step 3. 3. Inspect engine harness for visible signs of damage. If damage is found, contact Lycoming Engines. If no damage is found, go to step 4. 4. Complete a continuity test of the harness from the harness sensor connector A040-P to the ECU connector using the engine system schematic. If the continuity check fails, isolate to affected harness by disconnecting the firewall connection, then contact Lycoming Engines. If the continuity checks good, replace the ECU.					

Fault ID	279	Fault Group	35	Fault Name	<i>[FAULT: fuel pump pressure external]</i>
Fault Description	Primary: -reserved- Secondary: FPP External (Sensor Supply Fault)			Fault Lamp	TLO
Root Cause	This fault implies that the 5V sensor supply that is connected to the sensor is deemed INVALID. 1: The 5V supply may be INVALID due to a circuit fault or a slew-rate fault on the 5V supply. For details of the 5V Supply faults refer to Fault Ids 160-162, 196-198 and 264-266. 2: Multiple sensors may be connected to the same 5V supply so if it becomes INVALID then all the sensors that are connected to it would set corresponding External (sensor supply) faults. Refer to the system schematic to identify the sensors that may be connected to a 5V supply.				
Troubleshooting Steps					
1. Is there an active fault(s) that correspond to the fault numbers listed in the Root Cause box, items 1 and 2? If yes, go to troubleshooting procedure for the active fault(s). If no, go to step 2. 2. With the ECU powered on, use a multi-meter to measure the voltage at the sensor connector A014-P pin B (5V supply) and pin A (GND). Is 5V present on pin B? If yes, replace the sensor. If no, go to step 3. 3. Inspect engine harness for visible signs of damage. If damage is found, contact Lycoming Engines. If no damage is found, go to step 4. 4. Complete a continuity test of the harness from the harness sensor connector A014-P to the ECU connector using the engine system schematic. If the continuity check fails, isolate to affected harness by disconnecting the firewall connection, then contact Lycoming Engines. If the continuity checks good, replace the ECU.					

Fault ID	280	Fault Group	36	Fault Name	<i>[FAULT: analogue engine identifier external]</i>
Fault Description	Primary: -reserved- Secondary: Engine ID External (Sensor Supply Fault)		Fault Lamp	None	
Root Cause	<p>This fault implies that the 5V sensor supply that is connected to the sensor is deemed INVALID.</p> <p>1: The 5V supply may be INVALID due to a circuit fault or a slew-rate fault on the 5V supply. For details of the 5V Supply faults refer to Fault Ids 160-162, 196-198 and 264-266.</p> <p>2: Multiple sensors may be connected to the same 5V supply so if it becomes INVALID then all the sensors that are connected to it would set corresponding External (sensor supply) faults. Refer to the system schematic to identify the sensors that may be connected to a 5V supply.</p>				
Troubleshooting Steps					
<ol style="list-style-type: none"> 1. Is the fault active? If yes, go to step 2. If no, go to step 4. 2. With Ignition switch in OFF position, remove ECU power by pulling the ECU circuit breaker. Wait 10s before resetting. Is fault still active? If yes, go to step 3. If no, monitor engine operation for the fault to repeat. 3. Remove harness connector A001-P2 from ECU connector A001-J2. Using a multi-meter, check for continuity (or a specific resistance if a resistor is installed) between pins 33 and 42 of A001-P2. Does continuity (or correct resistance) exist? If yes, reconnect A001-J2, and go to step 4. If no, contact Lycoming Engines. 4. Clear Service fault history and turn ignition switch on. If the fault is still active replace the ECU. <p>NOTE: By default, this configurable parameter has been disabled hence this fault should only occur if this is enabled in the calibration for an engine specific installation.</p>					

Fault ID	281	Fault Group	36	Fault Name	<i>[FAULT: analogue pilot operating mode external]</i>
Fault Description	Primary: -reserved- Secondary: Operating Mode Selector External (Sensor Supply Fault)		Fault Lamp	None	
Root Cause	<p>This fault implies that the 5V sensor supply that is connected to the sensor is deemed INVALID.</p> <p>1: The 5V supply may be INVALID due to a circuit fault or a slew-rate fault on the 5V supply. For details of the 5V Supply faults refer to Fault Ids 160-162, 196-198 and 264-266.</p> <p>2: Multiple sensors may be connected to the same 5V supply so if it becomes INVALID then all the sensors that are connected to it would set corresponding External (sensor supply) faults. Refer to the system schematic to identify the sensors that may be connected to a 5V supply.</p>				
Troubleshooting Steps					
<ol style="list-style-type: none"> 1. Is there an active fault(s) that correspond to the fault numbers listed in the Root Cause box, items 1 and 2? If yes, go to troubleshooting procedure for the active fault(s). If no, go to step 2. 2. Inspect wires and resistors connected to switch for breaks or damage. Are wires or resistors broken or damaged? If yes, repair in accordance with the aircraft maintenance manual. If no, go to step 3. 					

Troubleshooting Steps (Cont.)

3. Disconnect wires from switch and disconnect ECU connector A001-P2. Measure resistance from A001-P2 pin 48 to each wire and check for resistance as shown in the table below. Are the resistances measured within the table limits? If yes, go to step 4. If no, but resistance is present and not within table limits, replace the defective resistor in accordance with the aircraft maintenance manual. If no, and circuit is open, go to step 5.

Switch Position	Resistance	Tolerance
C	330kΩ	±10%
NORM	1.01MΩ	±10%
S	3.21MΩ	±10%

4. Complete a continuity and short circuit test of the switch. If the continuity or short circuit check fails, replace the switch. If the continuity check is good, replace the ECU.
5. Complete a continuity test of the harness from the input side of each resistor to the ECU connector using the engine system schematic. If the continuity check fails, isolate to affected harness by disconnecting the airframe interface connection AF-P1. If the continuity fails between switch and AF-J1, repair cable in accordance with aircraft maintenance manual. If the continuity fails between AF-P1 and ECU, contact Lycoming Engines. If the continuity checks good, replace the ECU.

Fault ID	282	Fault Group	36	Fault Name	<i>[FAULT: turbine inlet temperature 1 external]</i>
Fault Description	Primary: TIT1 External (Sensor Supply Fault) Secondary: -reserved-			Fault Lamp	None
Root Cause	This fault implies that the Thermocouple offset voltage is deemed INVALID.				

Troubleshooting Steps

1. Run the engine in accordance with the engine and aircraft maintenance manuals. Is the fault active? If yes, go to step 3. If no, go to step 2.
2. Using the FST, download active and service fault logs, then clear fault logs and monitor engine operation for the fault to repeat.
3. Inspect TIT sensor, and lead for any damage (eg...burned, broken or frayed wires, cracked or broken connectors, burned or broken sensors). Replace any damaged sensors per the "Sensor Replacement Procedure" in Chapter 72-70. If no damage is found, go to step 4.
4. Inspect TIT harness connection for any damage (eg...burned, broken or frayed wires, cracked or broken connectors). Contact Lycoming if harness damage is found. If no damage found, go to step 5.
5. Complete a continuity test of the harness from the harness sensor connector to the ECU connector using the engine system schematic. If the continuity check fails, isolate to affected harness by disconnecting the firewall connection, then contact Lycoming Engines. If the continuity checks good, replace the sensor. If fault persists, replace the ECU.

Fault ID	283	Fault Group	36	Fault Name	<i>[FAULT: turbine inlet temperature 2 external]</i>
Fault Description	Primary: TIT2 External (Sensor Supply Fault) Secondary: -reserved-			Fault Lamp	None
Root Cause	This fault implies that the Thermocouple offset voltage is deemed INVALID.				
Troubleshooting Steps					
<ol style="list-style-type: none"> 1. Run the engine in accordance with the engine and aircraft maintenance manuals. Is the fault active? If yes, go to step 3. If no, go to step 2. 2. Using the FST, download active and service fault logs, then clear fault logs and monitor engine operation for the fault to repeat. 3. Inspect TIT sensor, and lead for any damage (eg...burned, broken or frayed wires, cracked or broken connectors, burned or broken sensors). Replace any damaged sensors per the "Sensor Replacement Procedure" in Chapter 72-70. If no damage is found, go to step 4. 4. Inspect TIT harness connection for any damage (eg...burned, broken or frayed wires, cracked or broken connectors). Contact Lycoming if harness damage is found. If no damage found, go to step 5. 5. Complete a continuity test of the harness from the harness sensor connector to the ECU connector using the engine system schematic. If the continuity check fails, isolate to affected harness by disconnecting the firewall connection, then contact Lycoming Engines. If the continuity checks good, replace the sensor. If fault persists, replace the ECU. 					

Fault ID	284	Fault Group	36	Fault Name	<i>[FAULT: Pilot Operating Mode Switch]</i>												
Fault Description	Primary: -reserved- Secondary: Operating Mode Selector Invalid Value			Fault Lamp	None												
Root Cause	This fault indicates an invalid interpolation of the analogue pilot mode input.																
Troubleshooting Steps																	
<ol style="list-style-type: none"> 1. Is there an active fault(s) that correspond to the fault numbers listed in the Root Cause box, items 1 and 2? If yes, go to troubleshooting procedure for the active fault(s). If no, go to step 2. 2. Inspect wires and resistors connected to switch for breaks or damage. Are wires or resistors broken or damaged? If yes, repair in accordance with the aircraft maintenance manual. If no, go to step 3. 3. Disconnect wires from switch and disconnect ECU connector A001-P2. Measure resistance from A001-P2 pin 48 to each wire and check for resistance as shown in the table below. Are the resistances measured within the table limits? If yes, go to step 4. If no, but resistance is present and not within table limits, replace the defective resistor in accordance with the aircraft maintenance manual. If no, and circuit is open, go to step 5. <table border="1" style="margin-left: auto; margin-right: auto;"> <thead> <tr> <th>Switch Position</th> <th>Resistance</th> <th>Tolerance</th> </tr> </thead> <tbody> <tr> <td>C</td> <td>330kΩ</td> <td>±10%</td> </tr> <tr> <td>NORM</td> <td>1.01MΩ</td> <td>±10%</td> </tr> <tr> <td>S</td> <td>3.21MΩ</td> <td>±10%</td> </tr> </tbody> </table> <ol style="list-style-type: none"> 4. Complete a continuity and short circuit test of the switch. If the continuity or short circuit check fails, replace the switch. If the continuity check is good, replace the ECU. 5. Complete a continuity test of the harness from the input side of each resistor to the ECU connector using the engine system schematic. If the continuity check fails, isolate to affected harness by disconnecting the airframe interface connection AF-P1. If the continuity fails between switch and AF-J1, repair cable in accordance with aircraft maintenance manual. If the continuity fails between AF-P1 and ECU, contact Lycoming Engines. If the continuity checks good, replace the ECU. 						Switch Position	Resistance	Tolerance	C	330kΩ	±10%	NORM	1.01MΩ	±10%	S	3.21MΩ	±10%
Switch Position	Resistance	Tolerance															
C	330kΩ	±10%															
NORM	1.01MΩ	±10%															
S	3.21MΩ	±10%															

Fault ID	285	Fault Group	36	Fault Name	<i>[FAULT: ACJ temperature external]</i>
Fault Description	Primary: ACJ Temperature External Fault Secondary: ACJ Temperature External Fault		Fault Lamp	None	
Root Cause	This fault implies that the Thermocouple offset voltage is deemed INVALID. 1: The Thermocouple offset voltage may be INVALID due to a circuit fault or a slew-rate fault on the Thermocouple offset voltage input. For details of the Thermocouple offset voltage slew-rate and Thermocouple offset voltage circuit fault refer to Fault Ids 163 and 201. 2: Multiple thermocouples (CHTs, EGTs and TIT) use the Thermocouple offset voltage to derive the corresponding temperatures so if it becomes INVALID then all the sensors that are connected to it would set corresponding External (sensor supply) faults				
Troubleshooting Steps					
1. With Ignition switch in OFF position, remove ECU power by pulling the ECU circuit breaker. Wait 10s before resetting. Is fault active? If no, go to step 2. If yes, replace the ECU. 2. Clear Service faults using the FST by following the steps outlined in the “Access the Field Service Tool” section in Appendix C or the latest revision of <i>SSP-118</i> . 3. If fault repeats, replace the ECU.					

Fault ID	286	Fault Group	36	Fault Name	<i>-Reserved-</i>
Fault Description			Fault Lamp	None	
Root Cause					
Troubleshooting Steps					

Fault ID	287	Fault Group	36	Fault Name	<i>-Reserved-</i>
Fault Description			Fault Lamp	None	
Root Cause					
Troubleshooting Steps					

Fault ID	288	Fault Group	37	Fault Name	<i>[FAULT: turbine inlet temperature discrepancy]</i>
Fault Description	TIT Discrepancy Fault		Fault Lamp	FFL	
Root Cause	This fault indicates TIT 1 and TIT 2 differ by more than a maximum discrepancy threshold. The fault will become inactive if TIT 1 and TIT 2 converge below the maximum discrepancy.				
Troubleshooting Steps					
1. Are there any active TIT slew rate, circuit or range faults? If yes, refer to troubleshooting section for the active fault. If no, go to step 2. 2. Contact Lycoming Engines.					

Fault ID	289	Fault Group	37	Fault Name	<i>[FAULT: manifold temperature discrepancy]</i>
Fault Description	Manifold Temperature Discrepancy Fault			Fault Lamp	FFL
Root Cause	This fault indicates MAT 1 and MAT 2 differ by more than a maximum discrepancy threshold. The fault will become inactive if MAT 1 and MAT 2 converge below the maximum discrepancy				
Troubleshooting Steps					
1. Are there any active MAT sensor slew rate, circuit or range faults? If yes, refer to troubleshooting section for the active fault. If no, go to step 2.					
2. Contact Lycoming Engines.					

Fault ID	290	Fault Group	37	Fault Name	<i>[FAULT: engine load airflow speed density vs venturi discrepancy]</i>
Fault Description	Engine Load airflow SD Vs Venturi Discrepancy fault			Fault Lamp	FFL
Root Cause	This fault indicates venturi airflow (primary airflow measurement) and speed density (secondary airflow measurement) differ by more than calibrated threshold. The fault will become inactive once the discrepancy between venturi and speed density airflow values are below the maximum discrepancy limit				
Troubleshooting Steps					
1. Are there any active slew rate, circuit or range faults for the venturi sensor, MAP sensor, MAT sensor, or Deck Temperature? If yes, refer to troubleshooting section for the active fault. If no, go to step 2.					
2. Contact Lycoming Engines.					

Fault ID	291	Fault Group	37	Fault Name	<i>[FAULT: engine load airflow speed throttle vs speed density discrepancy]</i>
Fault Description	Engine Load airflow ST Vs SD fault			Fault Lamp	FFL
Root Cause	This fault indicates ST airflow (tertiary airflow measurement) and speed density (secondary airflow measurement) differ by more than calibrated threshold. The fault will become inactive once the discrepancy between tertiary and speed density airflow values are below the maximum discrepancy limit				
Troubleshooting Steps					
1. Are there any active slew rate, circuit or range faults for the venturi sensor, MAP sensor, MAT sensor, or Deck Temperature? If yes, refer to troubleshooting section for the active fault. If no, go to step 2.					
2. Contact Lycoming Engines.					

Fault ID	292	Fault Group	37	Fault Name	<i>[FAULT: engine load airflow speed throttle vs venturi discrepancy]</i>
Fault Description	Engine Load airflow ST Vs Venturi fault			Fault Lamp	FFL
Root Cause	This fault indicates ST airflow (tertiary airflow measurement) and speed density (secondary airflow measurement) differ by more than calibrated threshold. The fault will become inactive once the discrepancy between tertiary and speed density airflow values are below the maximum discrepancy limit				
Troubleshooting Steps					
1. Are there any active slew rate, circuit or range faults for the venturi sensor, MAP sensor, MAT sensor, or Deck Temperature? If yes, refer to troubleshooting section for the active fault. If no, go to step 2.					
2. Contact Lycoming Engines.					

Fault ID	293	Fault Group	37	Fault Name	<i>[FAULT: deck pressure discrepancy]</i>
Fault Description	Deck Pressure discrepancy fault			Fault Lamp	FFL
Root Cause	This fault indicates primary channel and secondary channel deck pressure values differ by more than the calibrated maximum threshold. The fault will become inactive if the two values converge below the maximum threshold.				
Troubleshooting Steps					
1. Are there any active deck pressure sensor slew rate, circuit or range faults? If yes, refer to troubleshooting section for the active fault. If no, go to step 2. 2. Contact Lycoming Engines.					

Fault ID	294	Fault Group	37	Fault Name	<i>[FAULT: compressor inlet air pressure discrepancy]</i>
Fault Description	CIP discrepancy fault			Fault Lamp	FFL
Root Cause	This fault indicates primary channel and secondary channel CIP pressure values differ by more than the calibrated maximum threshold. The fault will become inactive if the two values converge below the maximum threshold.				
Troubleshooting Steps					
1. Are there any active CIP sensor slew rate, circuit or range faults? If yes, refer to troubleshooting section for the active fault. If no, go to step 2. 2. Contact Lycoming Engines.					

Fault ID	295	Fault Group	37	Fault Name	<i>[FAULT: throttle position discrepancy]</i>
Fault Description	TPS discrepancy fault			Fault Lamp	FFL
Root Cause	This fault indicates primary channel and secondary channel TPS values differ by more than the calibrated maximum threshold. The fault will become inactive if the two values converge below the maximum threshold.				
Troubleshooting Steps					
1. Are there any active TPS sensor slew rate, circuit or range faults? If yes, refer to troubleshooting section for the active fault. If no, go to step 2. 2. Contact Lycoming Engines.					

Fault ID	296	Fault Group	38	Fault Name	<i>[FAULT: turbine inlet temperature cross-check]</i>
Fault Description	TIT crosscheck fault			Fault Lamp	FFL
Root Cause	This fault indicates the combined and inferred turbine inlet temperature differ by more than a calibrated maximum threshold. The fault will become inactive if the combined and inferred turbine inlet temperatures converge				
Troubleshooting Steps					
1. Are there any active TIT sensor slew rate, circuit or range faults? If yes, refer to troubleshooting section for the active fault. If no, go to step 2. 2. Contact Lycoming Engines.					

Fault ID	297	Fault Group	38	Fault Name	<i>[FAULT: manifold temperature cross-check]</i>
Fault Description	Manifold Temperature crosscheck fault			Fault Lamp	FFL
Root Cause	This fault indicates the combined and inferred manifold temperature differ by more than a calibrated maximum threshold. The fault will become inactive if the combined and inferred values converge				
Troubleshooting Steps					
<ol style="list-style-type: none"> 1. Are there any active MAT sensor slew rate, circuit or range faults? If yes, refer to troubleshooting section for the active fault. If no, go to step 2. 2. Contact Lycoming Engines. 					

Fault ID	298	Fault Group	38	Fault Name	<i>[FAULT: deck temperature cross-check]</i>
Fault Description	Deck Temperature crosscheck fault			Fault Lamp	FFL
Root Cause	This fault indicates the combined and inferred deck temperature differ by more than a calibrated maximum threshold. The fault will become inactive if the combined and inferred values converge				
Troubleshooting Steps					
<ol style="list-style-type: none"> 1. Are there any active deck temperature sensor slew rate, circuit or range faults? If yes, refer to troubleshooting section for the active fault. If no, go to step 2. 2. Contact Lycoming Engines. 					

Fault ID	299	Fault Group	38	Fault Name	<i>[FAULT: manifold pressure cross-check]</i>
Fault Description	Manifold Pressure crosscheck fault			Fault Lamp	FFL
Root Cause	This fault indicates the combined and inferred manifold pressure from throttle position differ by more than a calibrated maximum threshold. The fault will become inactive if the combined and inferred values converge				
Troubleshooting Steps					
<ol style="list-style-type: none"> 1. Are there any active MAP sensor slew rate, circuit or range faults? If yes, refer to troubleshooting section for the active fault. If no, go to step 2. 2. Contact Lycoming Engines. 					

Fault ID	300	Fault Group	38	Fault Name	<i>[FAULT: air mass flow rate cross-check]</i>
Fault Description	Air mass flow crosscheck fault			Fault Lamp	FFL
Root Cause	This fault indicates the primary and secondary air mass flow differ by more than a calibrated maximum threshold. The fault will become inactive if the primary and secondary air mass flow rates converge				
Troubleshooting Steps					
<ol style="list-style-type: none"> 1. Are there any active venturi, CIP, or MAP sensor slew rate, circuit or range faults? If yes, refer to troubleshooting section for the active fault. If no, go to step 2. 2. Contact Lycoming Engines. 					

Fault ID	301	Fault Group	38	Fault Name	<i>[FAULT: deck pressure cross-check]</i>
Fault Description	Deck Pressure crosscheck fault			Fault Lamp	FFL
Root Cause	This fault indicates the combined and inferred manifold pressure from throttle position differ by more than a calibrated maximum threshold. The fault will become inactive if the combined and inferred values converge				
Troubleshooting Steps					
<ol style="list-style-type: none"> 1. Are there any active deck pressure sensor slew rate, circuit or range faults? If yes, refer to troubleshooting section for the active fault. If no, go to step 2. 2. Contact Lycoming Engines. 					

Fault ID	302	Fault Group	38	Fault Name	<i>[FAULT: fuel rail pressure cross-check]</i>
Fault Description	Fuel Rail Pressure crosscheck fault			Fault Lamp	FFL
Root Cause	This fault indicates the Fuel rail pressure and inferred pressure differ by more than a calibrated maximum threshold. The fault will become inactive if the combined and inferred values converge				
Troubleshooting Steps					
<ol style="list-style-type: none"> 1. Are there any active fuel rail pressure sensor slew rate, circuit or range faults? If yes, refer to troubleshooting section for the active fault. If no, go to step 2. 2. Contact Lycoming Engines. 					

Fault ID	303	Fault Group	38	Fault Name	<i>[FAULT: throttle position cross-check]</i>
Fault Description	Throttle position crosscheck fault			Fault Lamp	FFL
Root Cause	This fault indicates the arbitrated and inferred throttle position differ by more than a calibrated maximum threshold. The fault will become inactive if the arbitrated and inferred values converge				
Troubleshooting Steps					
<ol style="list-style-type: none"> 1. Are there any active airflow discrepancy or crosscheck, sensor slew rate, circuit or range faults? If yes, refer to troubleshooting section for the active fault. If no, go to step 2. 2. Contact Lycoming Engines. 					

Fault ID	304	Fault Group	39	Fault Name	<i>[FAULT: trip tacho time discrepancy]</i>
Fault Description	Trip Tacho time discrepancy fault			Fault Lamp	None
Root Cause	This fault indicates trip tacho time differs between primary and secondary channel possibly due to a memory corruption or one channel being down while the other was running.				
Troubleshooting Steps					
<ol style="list-style-type: none"> 1. With Ignition switch in OFF position, remove ECU power by pulling the ECU circuit breaker. Wait 10s before resetting. Is fault active? If no, go to step 2. If yes, go to step 3. 2. Clear Service faults using the FST by following the steps outlined in the “Access the Field Service Tool” section in Appendix C or the latest revision of <i>SSP-118</i>. 3. Set ignition switch to on, do not start engine, complete step 2. Is fault still active? If no, sequence complete. If yes, replace the ECU. 					

Fault ID	305	Fault Group	39	Fault Name	<i>[FAULT: trip tacho time invalid]</i>
Fault Description	Trip Tacho time invalid fault			Fault Lamp	None
Root Cause	This fault indicates trip tacho time is invalid possibly due to a data logger fault or EEPROM memory corruption.				
Troubleshooting Steps					
<ol style="list-style-type: none"> 1. If equipped with a data logger, continue step 1, if not, continue to step 2. Are there any active data logger faults? If no, go to step 2. If yes, go to step 3. 2. With Ignition switch in OFF position, remove ECU power by pulling the ECU circuit breaker. Wait 10s before resetting. Is fault active? If no, go to step 4. If yes, go to step 5. 3. Inspect data logger and cabling for damage. If damage is noted, repair damage in accordance with aircraft maintenance manual. If data logger is damaged, replace. 4. Clear Service faults using the FST by following the steps outlined in the “Access the Field Service Tool” section in Appendix C or the latest revision of <i>SSP-118</i>. 5. Set ignition switch to on, do not start engine, complete step 2. Is fault still active? If no, sequence complete. If yes, replace the ECU. 					

Fault ID	306	Fault Group	39	Fault Name	<i>[FAULT: trip time discrepancy]</i>
Fault Description	Trip time discrepancy fault			Fault Lamp	None
Root Cause	This fault indicates trip time differs between primary and secondary channel possibly due to a memory corruption or one channel being down while the other was running.				
Troubleshooting Steps					
<ol style="list-style-type: none"> 1. With Ignition switch in OFF position, remove ECU power by pulling the ECU circuit breaker. Wait 10s before resetting. Is fault active? If no, go to step 2. If yes, go to step 3. 2. Clear Service faults using the FST by following the steps outlined in the “Access the Field Service Tool” section in Appendix C or the latest revision of <i>SSP-118</i>. 3. Set ignition switch to on, start engine. Shut down engine, complete step 2. Is fault still active? If no, sequence complete. If yes, replace the ECU. 					

Fault ID	307	Fault Group	39	Fault Name	<i>[FAULT: trip time invalid]</i>
Fault Description	Trip time invalid fault			Fault Lamp	None
Root Cause	This fault indicates trip time is invalid possibly due to a data logger fault or EEPROM memory corruption.				
Troubleshooting Steps					
<ol style="list-style-type: none"> 1. If equipped with a data logger, continue step 1, if not, continue to step 2. Are there any active data logger faults? If no, go to step 2. If yes, go to step 3. 2. With Ignition switch in OFF position, remove ECU power by pulling the ECU circuit breaker. Wait 10s before resetting. Is fault active? If no, go to step 4. If yes, go to step 5. 3. Inspect data logger and cabling for damage. If damage is noted, repair damage in accordance with aircraft maintenance manual. If data logger is damaged, replace. 4. Clear Service faults using the FST by following the steps outlined in the “Access the Field Service Tool” section in Appendix C or the latest revision of <i>SSP-118</i>. 5. Set ignition switch to on, do not start engine, complete step 2. Is fault still active? If no, sequence complete. If yes, replace the ECU. 					

Fault ID	308	Fault Group	39	Fault Name	<i>[FAULT: tacho time discrepancy]</i>
Fault Description	Tacho time discrepancy fault			Fault Lamp	None
Root Cause	This fault indicates tacho time differs between primary and secondary channel possibly due to a memory corruption or one channel being down while the other was running.				
Troubleshooting Steps					
<ol style="list-style-type: none"> 1. With Ignition switch in OFF position, remove ECU power by pulling the ECU circuit breaker. Wait 10s before resetting. Is fault active? If no, go to step 2. If yes, go to step 3. 2. Clear Service faults using the FST by following the steps outlined in the “Access the Field Service Tool” section in Appendix C or the latest revision of <i>SSP-118</i>. 3. Set ignition switch to on, do not start engine, complete step 2. Is fault still active? If no, sequence complete. If yes, replace the ECU. 					

Fault ID	309	Fault Group	39	Fault Name	<i>[FAULT: tacho time invalid]</i>
Fault Description	Tacho time invalid fault			Fault Lamp	None
Root Cause	This fault indicates tacho time is invalid possibly due to a data logger fault or EEPROM memory corruption.				
Troubleshooting Steps					
<ol style="list-style-type: none"> 1. If equipped with a data logger, continue step 1, if not, continue to step 2. Are there any active data logger faults? If no, go to step 2. If yes, go to step 3. 2. With Ignition switch in OFF position, remove ECU power by pulling the ECU circuit breaker. Wait 10s before resetting. Is fault active? If no, go to step 4. If yes, go to step 5. 3. Inspect data logger and cabling for damage. If damage is noted, repair damage in accordance with aircraft maintenance manual. If data logger is damaged, replace. 4. Clear Service faults using the FST by following the steps outlined in the “Access the Field Service Tool” section in Appendix C or the latest revision of <i>SSP-118</i>. 5. Set ignition switch to on, do not start engine, complete step 2. Is fault still active? If no, sequence complete. If yes, replace the ECU. 					

Fault ID	310	Fault Group	39	Fault Name	<i>[FAULT: EEC time discrepancy]</i>
Fault Description	EEC time discrepancy fault*			Fault Lamp	None
Root Cause	This fault indicates EEC time differs between primary and secondary channel possibly due to a memory corruption or one channel being down while the other was running.				
Troubleshooting Steps					
<ol style="list-style-type: none"> 1. If equipped with a data logger, continue step 1, if not, continue to step 2. Are there any active data logger faults? If no, go to step 2. If yes, go to step 3. 2. With Ignition switch in OFF position, remove ECU power by pulling the ECU circuit breaker. Wait 10s before resetting. Is fault active? If no, go to step 4. If yes, go to step 5. 3. Inspect data logger and cabling for damage. If damage is noted, repair damage in accordance with aircraft maintenance manual. If data logger is damaged, replace. 4. Clear Service faults using the FST by following the steps outlined in the “Access the Field Service Tool” section in Appendix C or the latest revision of <i>SSP-118</i>. 5. Set ignition switch to on, do not start engine, complete step 4. Is fault still active? If no, sequence complete. If yes, replace the ECU. 					
*NOTE: This fault does not cause any performance or operational limitations.					

Fault ID	311	Fault Group	39	Fault Name	<i>[FAULT: EEC time invalid]</i>
Fault Description	EEC time invalid fault*			Fault Lamp	None
Root Cause	This fault indicates EEC time is invalid possibly due to a data logger fault or EEPROM memory corruption.				
Troubleshooting Steps					
<ol style="list-style-type: none"> 1. If equipped with a data logger, continue step 1, if not, continue to step 2. Are there any active data logger faults? If no, go to step 2. If yes, go to step 3. 2. With Ignition switch in OFF position, remove ECU power by pulling the ECU circuit breaker. Wait 10s before resetting. Is fault active? If no, go to step 4. If yes, go to step 5. 3. Inspect data logger and cabling for damage. If damage is noted, repair damage in accordance with aircraft maintenance manual. If data logger is damaged, replace. 4. Clear Service faults using the FST by following the steps outlined in the “Access the Field Service Tool” section in Appendix C or the latest revision of <i>SSP-118</i>. 5. Set ignition switch to on, do not start engine, complete step 4. Is fault still active? If no, sequence complete. If yes, replace the ECU. 					
*NOTE: This fault does not cause any performance or operational limitations.					

Fault ID	312	Fault Group	40	Fault Name	<i>[FAULT: TBO Clear Corrupt Record]</i>
Fault Description	TBO clear corrupt fault*			Fault Lamp	None
Root Cause	This fault indicates one or more corrupt records were found in the TBO fault clearing history block				
Troubleshooting Steps					
<ol style="list-style-type: none"> 1. With Ignition switch in OFF position, remove ECU power by pulling the ECU circuit breaker. Wait 10s before resetting. Is fault active? If no, go to step 2. If yes, go to step 3. 2. Clear Service faults using the FST by following the steps outlined in the “Access the Field Service Tool” section in Appendix C or the latest revision of <i>SSP-118</i>. 3. Set ignition switch to on, do not start engine, complete step 2. Is fault still active? If no, sequence complete. If yes, replace the ECU. 					
*NOTE: This fault does not cause any performance or operational limitations.					

Fault ID	313	Fault Group	40	Fault Name	<i>[FAULT: TBO Clear Full]</i>
Fault Description	TBO clear full fault*			Fault Lamp	None
Root Cause	This fault indicates the clearing history block is full				
Troubleshooting Steps					
<ol style="list-style-type: none"> 1. With Ignition switch in OFF position, remove ECU power by pulling the ECU circuit breaker. Wait 10s before resetting. Is fault active? If no, go to step 2. If yes, go to step 3. 2. Clear Service faults using the FST by following the steps outlined in the “Access the Field Service Tool” section in Appendix C or the latest revision of <i>SSP-118</i>. 3. Set ignition switch to on, do not start engine, complete step 2. Is fault still active? If no, sequence complete. If yes, replace the ECU. 					
*NOTE: This fault does not cause any performance or operational limitations.					

Fault ID	314	Fault Group	40	Fault Name	<i>[FAULT: TBO Corrupt Record]</i>
Fault Description	TBO corrupt record fault*			Fault Lamp	None
Root Cause	This fault indicates one or more corrupt records were found in the TBO fault record and scratch blocks				
Troubleshooting Steps					
<ol style="list-style-type: none"> 1. With Ignition switch in OFF position, remove ECU power by pulling the ECU circuit breaker. Wait 10s before resetting. Is fault active? If no, go to step 2. If yes, go to step 3. 2. Clear Service faults using the FST by following the steps outlined in the “Access the Field Service Tool” section in Appendix C or the latest revision of <i>SSP-118</i>. 3. Set ignition switch to on, do not start engine, complete step 2. Is fault still active? If no, sequence complete. If yes, replace the ECU. 					
*NOTE: This fault does not cause any performance or operational limitations.					

Fault ID	315	Fault Group	40	Fault Name	<i>[FAULT: TBO Integrity Failure]</i>
Fault Description	TBO integrity failure fault*			Fault Lamp	None
Root Cause	This fault indicates the ECU is unable to determine which TBO record block contains valid fault data				
Troubleshooting Steps					
<ol style="list-style-type: none"> 1. With Ignition switch in OFF position, remove ECU power by pulling the ECU circuit breaker. Wait 10s before resetting. Is fault active? If no, go to step 2. If yes, go to step 3. 2. Clear Service faults using the FST by following the steps outlined in the “Access the Field Service Tool” section in Appendix C or the latest revision of <i>SSP-118</i>. 3. Set ignition switch to on, do not start engine, complete step 2. Is fault still active? If no, sequence complete. If yes, replace the ECU. 					
*NOTE: This fault does not cause any performance or operational limitations.					

Fault ID	316	Fault Group	40	Fault Name	<i>[FAULT: TBO time discrepancy]</i>
Fault Description	TBO time discrepancy fault*			Fault Lamp	None
Root Cause	This fault indicates tacho time differs between primary and secondary channel possibly due to a memory corruption or one channel being down while the other was running.				
Troubleshooting Steps					
<ol style="list-style-type: none"> 1. With Ignition switch in OFF position, remove ECU power by pulling the ECU circuit breaker. Wait 10s before resetting. Is fault active? If no, go to step 2. If yes, go to step 3. 2. Clear Service faults using the FST by following the steps outlined in the “Access the Field Service Tool” section in Appendix C or the latest revision of <i>SSP-118</i>. 3. Set ignition switch to on, do not start engine, complete step 2. Is fault still active? If no, sequence complete. If yes, replace the ECU. 					
*NOTE: This fault does not cause any performance or operational limitations.					

Fault ID	317	Fault Group	40	Fault Name	<i>[FAULT: TBO time invalid]</i>
Fault Description	TBO time invalid fault			Fault Lamp	None
Root Cause	This fault indicates TBO time is invalid possibly due to a data logger fault or EEPROM memory corruption.				
Troubleshooting Steps					
<ol style="list-style-type: none"> 1. With Ignition switch in OFF position, remove ECU power by pulling the ECU circuit breaker. Wait 10s before resetting. Is fault active? If no, go to step 2. If yes, go to step 3. 2. Clear Service faults using the FST by following the steps outlined in the “Access the Field Service Tool” section in Appendix C or the latest revision of <i>SSP-118</i>. 3. Set ignition switch to on, do not start engine, complete step 2. Is fault still active? If no, sequence complete. If yes, replace the ECU. 					

Fault ID	318	Fault Group	40	Fault Name	<i>-Reserved-</i>
Fault Description				Fault Lamp	None
Root Cause					
Troubleshooting Steps					

Fault ID	319	Fault Group	40	Fault Name	<i>-Reserved-</i>
Fault Description				Fault Lamp	None
Root Cause					
Troubleshooting Steps					

Fault ID	320	Fault Group	41	Fault Name	<i>[FAULT: SH Priority 1 Corrupt Record]</i>
Fault Description	SH priority 1 corrupt record fault*			Fault Lamp	None
Root Cause	This fault indicates a memory corruption in the priority 1 service history rolling buffer				
Troubleshooting Steps					
<ol style="list-style-type: none"> 1. With Ignition switch in OFF position, remove ECU power by pulling the ECU circuit breaker. Wait 10s before resetting. Is fault active? If no, go to step 2. If yes, go to step 3. 2. Clear Service faults using the FST by following the steps outlined in the “Access the Field Service Tool” section in Appendix C or the latest revision of <i>SSP-118</i>. 3. Set ignition switch to on, do not start engine, complete step 2. Is fault still active? If no, sequence complete. If yes, replace the ECU. 					
*NOTE: This fault does not cause any performance or operational limitations.					

Fault ID	321	Fault Group	41	Fault Name	<i>[FAULT: SH Priority 2 Corrupt Record]</i>
Fault Description	SH priority 2 corrupt record fault*			Fault Lamp	None
Root Cause	This fault indicates a memory corruption in the priority 2 service history rolling buffer				
Troubleshooting Steps					
<ol style="list-style-type: none"> 1. With Ignition switch in OFF position, remove ECU power by pulling the ECU circuit breaker. Wait 10s before resetting. Is fault active? If no, go to step 2. If yes, go to step 3. 2. Clear Service faults using the FST by following the steps outlined in the “Access the Field Service Tool” section in Appendix C or the latest revision of <i>SSP-118</i>. 3. Set ignition switch to on, do not start engine, complete step 2. Is fault still active? If no, sequence complete. If yes, replace the ECU. 					
*NOTE: This fault does not cause any performance or operational limitations.					

Fault ID	322	Fault Group	41	Fault Name	<i>[FAULT: SH Priority 3 Corrupt Record]</i>
Fault Description	SH priority 3 corrupt record fault*			Fault Lamp	None
Root Cause	This fault indicates a memory corruption in the priority 3 service history rolling buffer				
Troubleshooting Steps					
<ol style="list-style-type: none"> 1. With Ignition switch in OFF position, remove ECU power by pulling the ECU circuit breaker. Wait 10s before resetting. Is fault active? If no, go to step 2. If yes, go to step 3. 2. Clear Service faults using the FST by following the steps outlined in the “Access the Field Service Tool” section in Appendix C or the latest revision of <i>SSP-118</i>. 3. Set ignition switch to on, do not start engine, complete step 2. Is fault still active? If no, sequence complete. If yes, replace the ECU. 					
*NOTE: This fault does not cause any performance or operational limitations.					

Fault ID	323	Fault Group	41	Fault Name	<i>[FAULT: SH Priority 4 Corrupt Record]</i>
Fault Description	SH priority 4 corrupt record fault*			Fault Lamp	None
Root Cause	This fault indicates a memory corruption in the priority 4 service history rolling buffer				
Troubleshooting Steps					
<ol style="list-style-type: none"> 1. With Ignition switch in OFF position, remove ECU power by pulling the ECU circuit breaker. Wait 10s before resetting. Is fault active? If no, go to step 2. If yes, go to step 3. 2. Clear Service faults using the FST by following the steps outlined in the “Access the Field Service Tool” section in Appendix C or the latest revision of <i>SSP-118</i>. 3. Set ignition switch to on, do not start engine, complete step 2. Is fault still active? If no, sequence complete. If yes, replace the ECU. 					
*NOTE: This fault does not cause any performance or operational limitations.					

Fault ID	324	Fault Group	41	Fault Name	<i>-Reserved-</i>
Fault Description				Fault Lamp	None
Root Cause					
Troubleshooting Steps					

Fault ID	325	Fault Group	41	Fault Name	<i>-Reserved-</i>
Fault Description				Fault Lamp	None
Root Cause					
Troubleshooting Steps					

Fault ID	326	Fault Group	41	Fault Name	<i>-Reserved-</i>
Fault Description				Fault Lamp	None
Root Cause					
Troubleshooting Steps					

Fault ID	327	Fault Group	41	Fault Name	<i>-Reserved-</i>
Fault Description				Fault Lamp	None
Root Cause					
Troubleshooting Steps					

Fault ID	328	Fault Group	42	Fault Name	<i>[FAULT: TLO lamp output failure]</i>
Fault Description	TLO lamp output failure fault			Fault Lamp	None
Root Cause	This fault indicates a lamp output failure has been consistently detected.				
Troubleshooting Steps					
<ol style="list-style-type: none"> 1. If annunciator uses an incandescent bulb, go to step 2. If annunciator uses an LED bulb, go to step 4. 2. Replace the bulb. Does fault become inactive. If yes, go to step 3. If no, go to step 4. 3. Clear Service faults using the FST by following the steps outlined in the “Access the Field Service Tool” section in Appendix C or the latest revision of <i>SSP-118</i>. 4. Remove connector/wires from annunciator. Complete continuity/short circuit test on annunciator assembly, using a multi-meter and aircraft wiring manual. If annunciator is defective, replace. If annunciator passes tests, go to step 5. 5. Complete a continuity test of the harness from the annunciator to the ECU connector using the engine system schematic in Appendix B and aircraft wiring diagram manual. If the continuity check fails, isolate to affected harness by disconnecting AF-P1. If engine airframe harness is at fault, contact Lycoming Engines. If aircraft wiring is at fault, repair in accordance with aircraft maintenance manual. If the continuity checks good, replace the annunciator. If fault persists, replace the ECU. 					
Fault ID	329	Fault Group	42	Fault Name	<i>[FAULT: TLO time remaining discrepancy]</i>
Fault Description	TLO time discrepancy fault			Fault Lamp	None
Root Cause	This fault indicates TLO time differs between primary and secondary channel possibly due to a memory corruption or one channel being down while the other was running.				
Troubleshooting Steps					
<ol style="list-style-type: none"> 1. With Ignition switch in OFF position, using the FST, reset the TLO timer by following the steps outlined in the “Access the Field Service Tool” section in Appendix C or the latest revision of <i>SSP-118</i>. 2. Set ignition switch to on, do not start engine, then Clear Service faults using the FST by following the steps outlined in the “Access the Field Service Tool” section in Appendix C or the latest revision of <i>SSP-118</i>. Is fault still active? If no, sequence complete. If yes, replace the ECU. 					
Fault ID	330	Fault Group	42	Fault Name	<i>[FAULT: TLO time remaining invalid]</i>
Fault Description	TLO time remaining invalid fault			Fault Lamp	None
Root Cause	This fault indicates TLO time is invalid possible due to data logger or EEPROM memory				
Troubleshooting Steps					
<ol style="list-style-type: none"> 1. If equipped with a data logger, are there any active data logger faults? If no, go to step 2. If yes, go to step 4. 2. With Ignition switch in OFF position, using the FST, reset the TLO timer by following the steps outlined in the “Access the Field Service Tool” section in Appendix C or the latest revision of <i>SSP-118</i>. Is the fault still active? If no, go to step 3. If yes, replace the ECU. 3. Set ignition switch to on, do not start engine, then Clear Service faults using the FST by following the steps outlined in the “Access the Field Service Tool” section in Appendix C or the latest revision of <i>SSP-118</i>. 4. Inspect data logger and cabling for damage. If damage is noted, repair damage in accordance with aircraft maintenance manual. If data logger is damaged, replace. Did data logger faults clear? If yes, then go to step 2. If no, go to step 5. 5. Complete a continuity test of the harness from the data logger connector to the ECU connector using the engine system schematic in Appendix B and aircraft wiring diagram manual. If the continuity check fails, isolate to affected harness by disconnecting AF-P1. If engine airframe harness is at fault, contact Lycoming Engines. If aircraft wiring is at fault, repair in accordance with aircraft maintenance manual. Are there any active data logger faults? If yes, contact Lycoming Engines. If no, go to step 2. 					

Fault ID	331	Fault Group	42	Fault Name	<i>-Reserved-</i>
Fault Description				Fault Lamp	None
Root Cause					
Troubleshooting Steps					

Fault ID	332	Fault Group	42	Fault Name	<i>-Reserved-</i>
Fault Description				Fault Lamp	None
Root Cause					
Troubleshooting Steps					

Fault ID	333	Fault Group	42	Fault Name	<i>-Reserved-</i>
Fault Description				Fault Lamp	None
Root Cause					
Troubleshooting Steps					

Fault ID	334	Fault Group	42	Fault Name	<i>-Reserved-</i>
Fault Description				Fault Lamp	None
Root Cause					
Troubleshooting Steps					

Fault ID	335	Fault Group	42	Fault Name	<i>-Reserved-</i>
Fault Description				Fault Lamp	None
Root Cause					
Troubleshooting Steps					

Fault ID	336	Fault Group	43	Fault Name	<i>[FAULT: APU power source cutoff]</i>
Fault Description	Power box power source fault			Fault Lamp	NTO
Root Cause	This fault indicates the average engine speed is consistently above the calibrated maximum engine speed to switch to PMA power source however AIRFRAME is still the Power Box power source. The fault is raised possibly due to a Power Box failure or Cam/crank sensor failure				
Troubleshooting Steps					
<ol style="list-style-type: none"> 1. Are there any active crankshaft or camshaft sensor faults? If yes, proceed to fault troubleshooting for that fault(s). If no, go to step 2. 2. Gain access to engine rear accessory drive area, and inspect the following items: <ul style="list-style-type: none"> • PMA for obvious damage and security. • Engine harness for obvious damage and security, including harness PMA connector. <p>Are the PMA and engine harness secure and show no physical damage? If yes, go to step 3. If no, complete the following for the finding:</p> <ul style="list-style-type: none"> • PMA not secure. <ul style="list-style-type: none"> ○ Remove PMA per the “PMA Removal” section in Chapter 73-10 and inspect PMA shaft and gear for damage. If damage is found, replace the PMA, and inspect accessory gear drive for damage. If no damage is found on either the PMA or accessory gear drive, reinstall PMA per the “PMA Installation” section in Chapter 73-10. • PMA damaged. Replace the PMA per the “Permanent Magnet Alternator (PMA) Replacement” section in Chapter 73-10. • Engine harness damaged. Contact Lycoming Engines. 3. Complete a continuity and short circuit test of the engine and engine airframe harnesses from PMA connector to the Power Box connector using the engine system schematic. If the continuity or short circuit check fails, isolate to affected harness by disconnecting the engine harness at the firewall connector, then contact Lycoming Engines. If both checks pass, replace the Power Box. Is fault still active? If yes, contact Lycoming Engines. If no, go to step 4. 4. Clear Service faults using the FST by following the steps outlined in the “Access the Field Service Tool” section in Appendix C or the latest revision of <i>SSP-118</i>. 					

Fault ID	337	Fault Group	43	Fault Name	<i>[FAULT: APU power source noise]</i>
Fault Description	Power box power noise fault			Fault Lamp	NTO
Root Cause	This fault indicates the digital input Power Box source has noise levels. The fault will become inactive if the noise is reduced.				
Troubleshooting Steps					
<p>1. Gain access to engine rear accessory drive area, and inspect the following items:</p> <ul style="list-style-type: none"> • PMA for obvious damage and security. • Engine harness for obvious damage and security, including harness PMA connector. <p>Are the PMA and engine harness secure and show no physical damage? If yes, go to step 2. If no, complete the following for the finding:</p> <ul style="list-style-type: none"> • PMA not secure. <ul style="list-style-type: none"> ○ Remove PMA per the “PMA Removal” section in Chapter 73-10 and inspect PMA shaft and gear for damage. If damage is found, replace the PMA, and inspect accessory gear drive for damage. If no damage is found on either the PMA or accessory gear drive, reinstall PMA per the “PMA Installation” section in Chapter 73-10. • PMA damaged. Replace the PMA per the “Permanent Magnet Alternator (PMA) Replacement” section in Chapter 73-10. • Engine harness damaged. Contact Lycoming Engines. <p>2. Complete a continuity and short circuit test of the engine and engine airframe harnesses from PMA connector to the Power Box connector using the engine system schematic. If the continuity or short circuit check fails, isolate to affected harness by disconnecting the engine harness at the firewall connector, then contact Lycoming Engines. If both checks pass, replace the Power Box. Is fault still active? If yes, contact Lycoming Engines. If no, go to step 3.</p> <p>3. Clear Service faults using the FST by following the steps outlined in the “Access the Field Service Tool” section in Appendix C or the latest revision of <i>SSP-118</i>.</p>					

Fault ID	338	Fault Group	43	Fault Name	<i>-Reserved-</i>
Fault Description				Fault Lamp	NTO
Root Cause					
Troubleshooting Steps					

Fault ID	339	Fault Group	43	Fault Name	<i>-Reserved-</i>
Fault Description				Fault Lamp	NTO
Root Cause					
Troubleshooting Steps					

Fault ID	340	Fault Group	43	Fault Name	<i>-Reserved-</i>
Fault Description				Fault Lamp	NTO
Root Cause					
Troubleshooting Steps					

Fault ID	341	Fault Group	43	Fault Name	<i>-Reserved-</i>
Fault Description				Fault Lamp	NTO
Root Cause					
Troubleshooting Steps					

Fault ID	342	Fault Group	43	Fault Name	<i>-Reserved-</i>
Fault Description				Fault Lamp	NTO
Root Cause					
Troubleshooting Steps					

Fault ID	343	Fault Group	43	Fault Name	<i>-Reserved-</i>
Fault Description				Fault Lamp	NTO
Root Cause					
Troubleshooting Steps					

Fault ID	344	Fault Group	44	Fault Name	<i>-Reserved-</i>
Fault Description				Fault Lamp	TLO
Root Cause					
Troubleshooting Steps					

Fault ID	345	Fault Group	44	Fault Name	<i>-Reserved-</i>
Fault Description				Fault Lamp	TLO
Root Cause					
Troubleshooting Steps					

Fault ID	346	Fault Group	44	Fault Name	<i>[FAULT: TIT over temperature]</i>
Fault Description	TIT over temperature fault			Fault Lamp	TLO
Root Cause	This fault indicates the turbine inlet temperature has exceeded its calibrated maximum threshold. The fault will become inactive if the turbine inlet temperature returns to normal operation.				
Troubleshooting Steps					
<ol style="list-style-type: none"> 1. Are there any active or logged slew rate or range faults on the suspected sensor? If yes, replace the sensor. If no, go to step 2. 2. Are there any active or logged fuel injector, detonation, fuel filter in the fault history that match the EEC hours for the TIT fault? If yes, go to troubleshooting procedure for that fault(s). If no, go to step 3. 3. Remove TIT sensor and inspect for physical damage to probe (eg...burnt end), connector or lead. Is there any damage to sensor? If yes, replace the sensor. If fault becomes inactive, go to step 6. If fault is still active after changing probe, or no damage to probe was found, go to step 4. 4. Complete a continuity and short circuit test of the engine and engine airframe harnesses from TIT sensor harness connector to the ECU connector using the engine system schematic. If the continuity or short circuit check fails, isolate to affected harness by disconnecting the engine harness at the firewall connector, then contact Lycoming Engines. 5. Clear Service faults using the FST by following the steps outlined in the "Access the Field Service Tool" section in Appendix C or the latest revision of <i>SSP-118</i>. 					

Fault ID	347	Fault Group	44	Fault Name	<i>-Reserved-</i>
Fault Description				Fault Lamp	TLO
Root Cause					
Troubleshooting Steps					

Fault ID	348	Fault Group	44	Fault Name	<i>-Reserved-</i>
Fault Description				Fault Lamp	TLO
Root Cause					
Troubleshooting Steps					

Fault ID	349	Fault Group	44	Fault Name	<i>-Reserved-</i>
Fault Description				Fault Lamp	TLO
Root Cause					
Troubleshooting Steps					

Fault ID	350	Fault Group	44	Fault Name	<i>-Reserved-</i>
Fault Description				Fault Lamp	TLO
Root Cause					
Troubleshooting Steps					

Fault ID	351	Fault Group	44	Fault Name	<i>-Reserved-</i>
Fault Description				Fault Lamp	TLO
Root Cause					
Troubleshooting Steps					

Fault ID	352	Fault Group	45	Fault Name	<i>[FAULT: local ignition switch noise]</i>
Fault Description	Local Ignition Switch Noise Fault			Fault Lamp	FFL
Root Cause	This fault indicates the local ignition switch is noisy. The fault will become inactive if the noise is reduced.				
Troubleshooting Steps					
<ol style="list-style-type: none"> 1. Inspect wires connected to switch for breaks or damage. Are wires broken or damaged? If yes, repair in accordance with the aircraft maintenance manual. If no, go to step 2. 2. Complete a continuity and short circuit test of the switch. If the continuity or short circuit check fails, replace the switch. If the continuity and short circuit test check is good, go to step 3. 3. Complete a continuity test of the harness from the switch connections to the ECU connector using the engine system schematic. If the continuity check fails, isolate to affected harness by disconnecting the airframe interface connection AF-P1. If the continuity fails between switch and AF-J1, repair cable in accordance with aircraft maintenance manual. If the continuity fails between AF-P1 and ECU, contact Lycoming Engines. If the continuity checks good, replace the ECU. 					

Fault ID	353	Fault Group	45	Fault Name	<i>[FAULT: ignition switch discrepancy]</i>
Fault Description	Local Ignition Switch Discrepancy Fault			Fault Lamp	FFL
Root Cause	This fault indicates the ignition switch differs between primary and secondary channels possibly due to a hardware issue				
Troubleshooting Steps					
<ol style="list-style-type: none"> 1. Is the fault active, or are there any active or logged ignition switch slew rate or circuit faults? If yes, go to step 2. 2. Inspect wires connected to switch for breaks or damage. Are wires broken or damaged? If yes, repair in accordance with the aircraft maintenance manual. If no, go to step 2. 3. Complete a continuity and short circuit test of the switch. If the continuity or short circuit check fails, replace the switch. If the continuity and short circuit test check is good, go to step 4. 4. Complete a continuity test of the harness from the switch connections to the ECU connector using the engine system schematic. If the continuity check fails, isolate to affected harness by disconnecting the airframe interface connection AF-P1. If the continuity fails between switch and AF-J1, repair cable in accordance with aircraft maintenance manual. If the continuity fails between AF-P1 and ECU, contact Lycoming Engines. If the continuity checks good, replace the ECU. 					

Fault ID	354	Fault Group	45	Fault Name	<i>-Reserved-</i>
Fault Description				Fault Lamp	FFL
Root Cause					
Troubleshooting Steps					

Fault ID	355	Fault Group	45	Fault Name	<i>-Reserved-</i>
Fault Description				Fault Lamp	FFL
Root Cause					
Troubleshooting Steps					

Fault ID	356	Fault Group	45	Fault Name	<i>-Reserved-</i>
Fault Description				Fault Lamp	FFL
Root Cause					
Troubleshooting Steps					

Fault ID	357	Fault Group	45	Fault Name	<i>-Reserved-</i>
Fault Description				Fault Lamp	FFL
Root Cause					
Troubleshooting Steps					

Fault ID	358	Fault Group	45	Fault Name	<i>-Reserved-</i>
Fault Description				Fault Lamp	FFL
Root Cause					
Troubleshooting Steps					

Fault ID	359	Fault Group	45	Fault Name	<i>-Reserved-</i>
Fault Description				Fault Lamp	FFL
Root Cause					
Troubleshooting Steps					

Fault ID	360	Fault Group	46	Fault Name	<i>[FAULT: Power Down Diagnostic Failure]</i>
Fault Description	Power Down diagnostic failure fault			Fault Lamp	None
Root Cause	This fault indicates the power remains on after a power down warning was detected.				
Troubleshooting Steps					
<ol style="list-style-type: none"> 1. With Ignition switch in OFF position, remove ECU power by pulling the ECU circuit breaker. Wait 10s before resetting. Is fault active? If no, go to step 2. If yes, replace the Power Box. 2. Clear Service faults using the FST by following the steps outlined in the “Access the Field Service Tool” section in Appendix C or the latest revision of <i>SSP-118</i>. 					

Fault ID	361	Fault Group	46	Fault Name	<i>[FAULT: Power Down Diagnostic Noise]</i>												
Fault Description	Power Down diagnostic noise fault			Fault Lamp	None												
Root Cause	This fault indicates the power down diagnostic pin is noisy.																
Troubleshooting Steps																	
<ol style="list-style-type: none"> 1. Is the fault active? If no, go to step 2. If yes, are there any other active or logged Power Box (APU) faults? If yes, replace the Power Box. If no, go to step 3. 2. Clear Service faults using the FST by following the steps outlined in the “Access the Field Service Tool” section in Appendix C or the latest revision of <i>SSP-118</i>. 3. Complete a continuity test and short circuit test of the harness as shown in the table below using a multi-meter and the engine system schematic. If the continuity check fails, contact Lycoming Engines. If the continuity checks good, replace the Power Box. Then go to step 2. 																	
<table border="1" style="width: 100%; border-collapse: collapse;"> <thead> <tr> <th style="width: 25%;">ECU Connector</th> <th style="width: 10%;">Pin</th> <th style="width: 25%;">Power Box Connector</th> <th style="width: 10%;">Pin</th> </tr> </thead> <tbody> <tr> <td>A001-P1 (PRI)</td> <td>77</td> <td>A002-P1 (PRI)</td> <td>22</td> </tr> <tr> <td>A001-P2 (SEC)</td> <td>77</td> <td>A002-P2 (SEC)</td> <td>22</td> </tr> </tbody> </table>						ECU Connector	Pin	Power Box Connector	Pin	A001-P1 (PRI)	77	A002-P1 (PRI)	22	A001-P2 (SEC)	77	A002-P2 (SEC)	22
ECU Connector	Pin	Power Box Connector	Pin														
A001-P1 (PRI)	77	A002-P1 (PRI)	22														
A001-P2 (SEC)	77	A002-P2 (SEC)	22														

Fault ID	362	Fault Group	46	Fault Name	<i>-Reserved-</i>
Fault Description				Fault Lamp	None
Root Cause					
Troubleshooting Steps					

Fault ID	363	Fault Group	46	Fault Name	<i>-Reserved-</i>
Fault Description				Fault Lamp	None
Root Cause					
Troubleshooting Steps					

Fault ID	364	Fault Group	46	Fault Name	<i>-Reserved-</i>
Fault Description				Fault Lamp	None
Root Cause					
Troubleshooting Steps					

Fault ID	365	Fault Group	46	Fault Name	<i>-Reserved-</i>
Fault Description				Fault Lamp	None
Root Cause					
Troubleshooting Steps					

Fault ID	366	Fault Group	46	Fault Name	<i>-Reserved-</i>
Fault Description				Fault Lamp	None
Root Cause					
Troubleshooting Steps					

Fault ID	367	Fault Group	46	Fault Name	<i>-Reserved-</i>
Fault Description				Fault Lamp	None
Root Cause					
Troubleshooting Steps					



Fault ID	368	Fault Group	47	Fault Name	<i>[FAULT: placard condition time discrepancy]</i>
Fault Description	Placard condition time discrepancy fault			Fault Lamp	TLO
Root Cause	This fault indicates the placard condition time for the primary and secondary channels differ by more than a maximum threshold. This fault will become inactive if the two channel placard timer converge				
Fault ID	369	Fault Group	47	Fault Name	<i>[FAULT: placard condition time invalid]</i>
Fault Description	Placard condition time invalid fault			Fault Lamp	TLO
Root Cause	This fault indicates the placard condition time is invalid on both primary and secondary channel possibly due to a non-volatile memory issue				
Fault ID	370	Fault Group	47	Fault Name	<i>[FAULT: placard condition active]</i>
Fault Description	Placard condition time invalid fault			Fault Lamp	TLO
Root Cause	This fault indicates the engine has been operating outside of safe limits for more than the consecutive allowable time. The fault will become inactive if the engine operating returns to normal				
Troubleshooting Steps for Faults 368 thru 370					
These configurable features are disabled in the system on all electronic engine configurations					

Fault ID	371	Fault Group	47	Fault Name	<i>-Reserved-</i>
Fault Description				Fault Lamp	TLO
Root Cause					
Troubleshooting Steps					

Fault ID	372	Fault Group	47	Fault Name	<i>-Reserved-</i>
Fault Description				Fault Lamp	TLO
Root Cause					
Troubleshooting Steps					

Fault ID	373	Fault Group	47	Fault Name	<i>-Reserved-</i>
Fault Description				Fault Lamp	TLO
Root Cause					
Troubleshooting Steps					

Fault ID	374	Fault Group	47	Fault Name	<i>-Reserved-</i>
Fault Description				Fault Lamp	TLO
Root Cause					
Troubleshooting Steps					

Fault ID	375	Fault Group	47	Fault Name	<i>-Reserved-</i>
Fault Description				Fault Lamp	TLO
Root Cause					
Troubleshooting Steps					

Fault ID	376	Fault Group	48	Fault Name	<i>[FAULT: EEPROM fixed location failure]</i>
Fault Description	EEPROM fixed location failure fault			Fault Lamp	None
Root Cause	This fault indicates a failure to write to the EEPROM. The fault will become inactive if an EEPROM write is successful.				
Fault ID	377	Fault Group	48	Fault Name	<i>[FAULT: EEPROM fixed read failure]</i>
Fault Description	EEPROM fixed read failure fault			Fault Lamp	None
Root Cause	This fault indicates a failure to read from the EEPROM. The fault will become inactive if an EEPROM read is successful.				
Fault ID	378	Fault Group	48	Fault Name	<i>[FAULT: EEPROM rolling buffer failure]</i>
Fault Description	EEPROM rolling buffer fault			Fault Lamp	None
Root Cause	This fault indicates a failure to read from the EEPROM. The fault will become inactive if an EEPROM read is successful.				
Troubleshooting Steps for Faults 376 thru 378					
<ol style="list-style-type: none"> 1. With Ignition switch in OFF position, remove ECU power by pulling the ECU circuit breaker. Wait 10s before resetting. Is fault active? If no, go to step 2. If yes, replace the ECU. 2. Clear Service faults using the FST by following the steps outlined in the “Access the Field Service Tool” section in Appendix C or the latest revision of <i>SSP-118</i>. 					

Fault ID	379	Fault Group	48	Fault Name	<i>-Reserved-</i>
Fault Description				Fault Lamp	None
Root Cause					
Troubleshooting Steps					

Fault ID	380	Fault Group	48	Fault Name	<i>-Reserved-</i>
Fault Description				Fault Lamp	None
Root Cause					
Troubleshooting Steps					

Fault ID	381	Fault Group	48	Fault Name	<i>-Reserved-</i>
Fault Description				Fault Lamp	None
Root Cause					
Troubleshooting Steps					

Fault ID	382	Fault Group	48	Fault Name	<i>-Reserved-</i>
Fault Description				Fault Lamp	None
Root Cause					
Troubleshooting Steps					

Fault ID	383	Fault Group	48	Fault Name	<i>-Reserved-</i>
Fault Description				Fault Lamp	None
Root Cause					
Troubleshooting Steps					

Fault ID	384	Fault Group	49	Fault Name	<i>[FAULT: BOOT CAN ERROR]</i>
Fault Description	Boot mode CAN error			Fault Lamp	None
Root Cause	This fault indicates a CAN error occurred while in boot mode				
Fault ID	385	Fault Group	49	Fault Name	<i>[FAULT: BOOT COMMS TIMEOUT]</i>
Fault Description	Boot mode service tool timeout			Fault Lamp	None
Root Cause	This fault indicates a loss of communication with service tool while in boot mode				
Fault ID	386	Fault Group	49	Fault Name	<i>[FAULT: BOOT PROG ERROR]</i>
Fault Description	Boot mode programming error			Fault Lamp	None
Root Cause	This fault indicates a failure to program the unit potentially due to flash memory corruption				
Troubleshooting Steps for Faults 384 thru 386					
<ol style="list-style-type: none"> 1. With Ignition switch in OFF position, remove ECU power by pulling the ECU circuit breaker. Wait 10s before resetting. Is fault active? If no, go to step 2. If yes, replace the ECU. 2. Clear Service faults using the FST by following the steps outlined in the “Access the Field Service Tool” section in Appendix C or the latest revision of <i>SSP-118</i>. 					

Fault ID	387	Fault Group	49	Fault Name	<i>[FAULT: Timestamp Software Calibration Version Discrepancy]</i>
Fault Description	Software calibration version timestamp discrepancy fault			Fault Lamp	None
Root Cause	This fault indicates timestamp entry contains different application software version potentially due to a memory corruption				
Fault ID	388	Fault Group	49	Fault Name	<i>[FAULT: Timestamp Software Program Version Discrepancy]</i>
Fault Description	Software program version timestamp discrepancy fault			Fault Lamp	None
Root Cause	This fault indicates timestamp entry contains different factory unit calibration version potentially due to a memory corruption				
Fault ID	389	Fault Group	49	Fault Name	<i>[FAULT: Flash SPI Erase Fail]</i>
Fault Description	Flash SPI erase fail fault			Fault Lamp	None
Root Cause	This fault indicates a failure to erase the flash memory potentially due to flash memory corruption.				
Fault ID	390	Fault Group	49	Fault Name	<i>[FAULT: Flash SPI read Fail]</i>
Fault Description	Flash SPI read fail fault			Fault Lamp	None
Root Cause	This fault indicates a failure to read the flash memory potentially due to flash memory corruption.				
Fault ID	391	Fault Group	49	Fault Name	<i>[FAULT: Flash SPI write Fail]</i>
Fault Description	Flash SPI write fail fault			Fault Lamp	None
Root Cause	This fault indicates a failure to write to the flash memory potentially due to flash memory corruption.				
Troubleshooting Steps for Faults 387 thru 391					
<ol style="list-style-type: none"> 1. With Ignition switch in OFF position, remove ECU power by pulling the ECU circuit breaker. Wait 10s before resetting. Is fault active? If no, go to step 3. If yes, go to step 2. 2. Contact Lycoming Engines to correct the calibration files and reflash the ECU. Is fault still active? If no, go to step 3. If yes, replace the ECU. 3. Clear Service faults using the FST by following the steps outlined in the “Access the Field Service Tool” section in Appendix C or the latest revision of <i>SSP-118</i>. 					

Fault ID	392	Fault Group	50	Fault Name	<i>[FAULT: control priority message out-of-sync]</i>
Fault Description	Control Priority message out-of-sync-fault			Fault Lamp	NTO
Root Cause	This fault indicates the PWM and CAN 1 control state disagree for a period of time possibly due to an unexpected response from standby channel (unexpected heartbeat) or CAN 1 failure				
Fault ID	393	Fault Group	50	Fault Name	<i>[FAULT: control priority PWM]</i>
Fault Description	Control Priority PWM heartbeat duty cycle fault			Fault Lamp	NTO
Root Cause	This fault indicates remote PWM heartbeat has an invalid frequency or duty cycle possibly due to an unexpected response from standby channel				
Fault ID	394	Fault Group	50	Fault Name	<i>[FAULT: remote PWM heartbeat duty cycle]</i>
Fault Description	Remote PWM heartbeat duty cycle fault			Fault Lamp	NTO
Root Cause	This fault indicates remote PWM heartbeat has an invalid duty cycle possibly due to an unexpected response from standby channel				
Fault ID	395	Fault Group	50	Fault Name	<i>[FAULT: control priority PWM frequency invalid]</i>
Fault Description	Control Priority PWM invalid frequency			Fault Lamp	NTO
Root Cause	This fault indicates remote PWM heartbeat has an invalid frequency possibly due to an unexpected response from standby channel				
Troubleshooting Steps for Faults 392 thru 395					
1. With Ignition switch in OFF position, remove ECU power by pulling the ECU circuit breaker. Wait 10s before resetting. Is fault active? If no, go to step 2. If yes, replace the ECU. 2. Clear Service faults using the FST by following the steps outlined in the “Access the Field Service Tool” section in Appendix C or the latest revision of <i>SSP-118</i> .					

Fault ID	396	Fault Group	50	Fault Name	<i>-Reserved-</i>
Fault Description				Fault Lamp	NTO
Root Cause					
Troubleshooting Steps					

Fault ID	397	Fault Group	50	Fault Name	<i>-Reserved-</i>
Fault Description				Fault Lamp	NTO
Root Cause					
Troubleshooting Steps					

Fault ID	398	Fault Group	50	Fault Name	<i>-Reserved-</i>
Fault Description				Fault Lamp	NTO
Root Cause					
Troubleshooting Steps					

Fault ID	399	Fault Group	50	Fault Name	<i>-Reserved-</i>
Fault Description				Fault Lamp	NTO
Root Cause					
Troubleshooting Steps					

Fault ID	400	Fault Group	51	Fault Name	<i>[FAULT: QADC calibration failure]</i>
Fault Description	QADC calibration failure fault			Fault Lamp	None
Root Cause	This fault indicates a failure to write to the flash memory potentially due to flash memory corruption.				
Fault ID	401	Fault Group	51	Fault Name	<i>[FAULT: QADC Initialization]</i>
Fault Description	QADC Initialization fault			Fault Lamp	None
Root Cause	This fault indicates QADC has failed to initialize properly potentially due to a hardware failure in the QADC. The fault will become inactive if the converter successfully initializes on subsequent attempts.				
Fault ID	402	Fault Group	51	Fault Name	<i>[FAULT: QADC scan overrun]</i>
Fault Description	QADC scan overrun fault			Fault Lamp	None
Root Cause	This fault indicates QADC has failed to sample the analogue channels every 1ms potentially due to a hardware failure in the converter. The fault will become inactive if the converter returns to normal function				
Fault ID	403	Fault Group	51	Fault Name	<i>[FAULT: Consistency QADC]</i>
Fault Description	QADC consistency fault			Fault Lamp	None
Root Cause	This fault indicates a memory corruption has affected the QADC				
Troubleshooting Steps for Faults 400 thru 403					
<ol style="list-style-type: none"> 1. With Ignition switch in OFF position, remove ECU power by pulling the ECU circuit breaker. Wait 10s before resetting. Is fault active? If no, go to step 3. If yes, go to step 2. 2. Contact Lycoming Engines to correct the calibration files and reflash the ECU. Is fault still active? If no, go to step 3. If yes, replace the ECU. 3. Clear Service faults using the FST by following the steps outlined in the “Access the Field Service Tool” section in Appendix C or the latest revision of <i>SSP-118</i>. 					

Fault ID	404	Fault Group	51	Fault Name	<i>-Reserved-</i>
Fault Description				Fault Lamp	None
Root Cause					
Troubleshooting Steps					

Fault ID	405	Fault Group	51	Fault Name	<i>-Reserved-</i>
Fault Description				Fault Lamp	None
Root Cause					
Troubleshooting Steps					

Fault ID	406	Fault Group	51	Fault Name	<i>-Reserved-</i>
Fault Description				Fault Lamp	None
Root Cause					
Troubleshooting Steps					

Fault ID	407	Fault Group	51	Fault Name	<i>-Reserved-</i>
Fault Description				Fault Lamp	None
Root Cause					
Troubleshooting Steps					

Fault ID	408	Fault Group	52	Fault Name	<i>[FAULT: ADL hardware failure]</i>
Fault Description	Data logger failure fault			Fault Lamp	None
Root Cause	This fault could be caused from multiple data logger hardware issues such as: RTC battery low, missing calibration data, Manufacturer ID is incorrected, RTC is incorrect or the Accelerometer is broken. The fault will become inactive if the data logger hardware issue is resolved				
Troubleshooting Steps					
<ol style="list-style-type: none"> 1. Is fault active? If yes, replace the data logger, then go to step 3. If no, go to step 2. 2. Is fault 410 (<i>ADL_STATE_RTC reception failure</i>) * active or logged? If no, go to step 3. If yes replace the data logger and go to step 3. 3. Clear Service faults using the FST by following the steps outlined in the “Access the Field Service Tool” section in Appendix C or the latest revision of <i>SSP-118</i>. <p>*NOTE: The ADL hardware fault and ADL_STATE_RTC reception failure fault occurring simultaneously is an indication that the ADL RTC battery is depleted.</p>					

Fault ID	409	Fault Group	52	Fault Name	<i>[FAULT: ADL software error]</i>
Fault Description	Data logger software error fault			Fault Lamp	None
Root Cause	This fault indicates the data logger task wasn't completed in its allotted time possibly due to a software functionality issue.				
Troubleshooting Steps					
<ol style="list-style-type: none"> 1. With Ignition switch in OFF position, remove ECU power by pulling the ECU circuit breaker. Wait 10s before resetting. Is fault active? If no, go to step 3. If yes, go to step 2. 2. Contact Lycoming Engines to correct the calibration files and reflash the ADL. Is fault still active? If no, go to step 3. If yes, replace ADL. 3. Clear Service faults using the FST by following the steps outlined in the “Access the Field Service Tool” section in Appendix C or the latest revision of <i>SSP-118</i>. 					

Fault ID	410	Fault Group	52	Fault Name	<i>[FAULT: ADL_STATE_RTC reception failure]</i>
Fault Description	Data logger state/RTC message reception failure fault			Fault Lamp	None
Root Cause	This fault indicates a failure receiving the appropriate message from data logger possibly due to an issue with data logger communications				
Troubleshooting Steps					
<ol style="list-style-type: none"> 1. Is fault active or logged? If yes, go to step 2. If no, go to step 4. 2. Is fault 408 (<i>ADL hardware failure</i>) active? If yes, replace the data logger then go to step 5. If no, go to step 3. 3. Inspect data logger and cabling for damage. If damage is noted, repair damage in accordance with aircraft maintenance manual. If data logger is damaged, replace. If no damage noted, go to step 4. 4. Complete a continuity test of the harness from the data logger connector to the ECU connector using the engine system schematic in Appendix B and airframe wiring manual. If the continuity check fails, isolate to affected harness by disconnecting the airframe interface connection AF-P1. If the continuity fails between the data logger and AF-J1, repair cable in accordance with aircraft maintenance manual. If the continuity fails between AF-P1 and ECU, contact Lycoming Engines. If the continuity checks good, replace the data logger. 5. Clear Service faults using the FST by following the steps outlined in the “Access the Field Service Tool” section in Appendix C or the latest revision of <i>SSP-118</i>. <p>*NOTE: The ADL hardware fault and ADL_STATE_RTC reception failure fault occurring simultaneously is an indication that the ADL RTC battery is depleted.</p>					

Fault ID	411	Fault Group	52	Fault Name	<i>-Reserved-</i>
Fault Description				Fault Lamp	None
Root Cause					
Troubleshooting Steps					

Fault ID	412	Fault Group	52	Fault Name	<i>-Reserved-</i>
Fault Description				Fault Lamp	None
Root Cause					
Troubleshooting Steps					

Fault ID	413	Fault Group	52	Fault Name	<i>-Reserved-</i>
Fault Description				Fault Lamp	None
Root Cause					
Troubleshooting Steps					

Fault ID	414	Fault Group	52	Fault Name	<i>-Reserved-</i>
Fault Description				Fault Lamp	None
Root Cause					
Troubleshooting Steps					

Fault ID	415	Fault Group	52	Fault Name	<i>-Reserved-</i>
Fault Description				Fault Lamp	None
Root Cause					
Troubleshooting Steps					

Fault ID	416	Fault Group	53	Fault Name	<i>[FAULT: crank vs cam speed discrepancy]</i>
Fault Description	Crank Vs Cam speed discrepancy fault			Fault Lamp	TLO
Root Cause	This fault indicates the engine speed calculated from the Crank differs from the engine speed calculated from the Cam by more than a maximum calibrated threshold. This fault will become inactive if the Crank and Cam speeds converge.				
Troubleshooting Steps					
<ol style="list-style-type: none"> 1. Is there a corresponding cam or crankshaft sensor circuit fault, active or logged? If yes, replace the sensor with corresponding fault. If no, go to step 2. 2. Run the engine in accordance with the engine and aircraft maintenance manuals. Is the fault active? If yes, go to step 4. If no, go to step 3. 3. Using the FST, download active and service fault logs. Review logs to ensure the engine was not operated in a placarded region identified by Lycoming Engines. Then go to step 8. 4. Inspect the cam and crank sensors, sensor leads and connectors. If there is damage found, replace the damaged sensor per the “Sensor Replacement Procedure” in Chapter 72-70. If there is no damage, go to step 5. 5. Inspect engine harness for visible signs of damage. If damage is found, contact Lycoming Engines. If no damage is found, go to step 6. 6. Swap the crank sensor with a new sensor and run the engine. Is the fault active? If yes, swap the new sensor in the crank position with the cam sensor, reinstall the original crank sensor, and run the engine. Is the fault active? If yes, go to step 7. If no, go to step 8. 7. Complete a continuity test of the harness from the engine harness crank and cam sensor connectors to the ECU connector using the engine system schematic. If the continuity check fails, isolate to affected harness by disconnecting the firewall connection, then contact Lycoming Engines. If the continuity checks good, replace the ECU. 8. Clear Service faults using the FST by following the steps outlined in the “Access the Field Service Tool” section in Appendix C or the latest revision of <i>SSP-118</i>. 					

Fault ID	417	Fault Group	53	Fault Name	<i>[FAULT: engine over speed]</i>
Fault Description	Engine over speed fault			Fault Lamp	TLO
Root Cause	This fault indicates the engine speed has exceeded its speed limit for more than the calibrated time to initiate cylinder cut.				
Troubleshooting Steps					
<ol style="list-style-type: none"> 1. Using the FST, download active and service fault logs. Review logs to verify the occurrence of an engine overspeed (2750 RPM exceeding 3 seconds) as defined in the latest revision of SB369, Engine Inspection after Overspeed. If overspeed occurred, go to step 2. If the overspeed did not occur or is within the limits of a momentary overspeed as defined by SB369, go to step 3. 2. Complete overspeed inspection in accordance with the latest revision of SB369. 3. Clear Service faults using the FST by following the steps outlined in the “Access the Field Service Tool” section in Appendix C or the latest revision of <i>SSP-118</i>. 					

Fault ID	418	Fault Group	53	Fault Name	<i>[FAULT: engine speed discrepancy]</i>
Fault Description	Engine speed discrepancy fault			Fault Lamp	TLO
Root Cause	This fault indicates the average engine speed between primary and secondary channels differ by more than a maximum threshold				
Troubleshooting Steps					
1. With Ignition switch in OFF position, remove ECU power by pulling the ECU circuit breaker. Wait 10s before resetting. Is fault active? If no, go to step 3. If yes, go to step 2. 2. Contact Lycoming Engines to correct the calibration files and reflash the ECU. Is fault still active? If no, go to step 3. If yes, replace ECU. 3. Clear Service faults using the FST by following the steps outlined in the “Access the Field Service Tool” section in Appendix C or the latest revision of <i>SSP-118</i> .					

Fault ID	419	Fault Group	53	Fault Name	<i>-Reserved-</i>
Fault Description				Fault Lamp	TLO
Root Cause					
Troubleshooting Steps					

Fault ID	420	Fault Group	53	Fault Name	<i>-Reserved-</i>
Fault Description				Fault Lamp	TLO
Root Cause					
Troubleshooting Steps					

Fault ID	421	Fault Group	53	Fault Name	<i>-Reserved-</i>
Fault Description				Fault Lamp	TLO
Root Cause					
Troubleshooting Steps					

Fault ID	422	Fault Group	53	Fault Name	<i>-Reserved-</i>
Fault Description				Fault Lamp	TLO
Root Cause					
Troubleshooting Steps					

Fault ID	423	Fault Group	53	Fault Name	<i>-Reserved-</i>
Fault Description				Fault Lamp	TLO
Root Cause					
Troubleshooting Steps					

Fault ID	424	Fault Group	54	Fault Name	<i>[FAULT: fuel filter pressure drop exceeded 1]</i>
Fault Description	Fuel filter pressure drop limit 1 exceeded Fault			Fault Lamp	FFL
Root Cause	This fault indicates the fuel filter drop pressure drop has consistently exceeded its maximum allowable threshold. This indicates a minor restricted flow between the fuel pump outlet pressure and fuel rail pressure				
Troubleshooting Steps					
<ol style="list-style-type: none"> 1. Run the engine in accordance with the engine and aircraft maintenance manuals. Is the fault active? If yes, go to step 2. If no, go to step 4. 2. Are there any active or logged fuel pressure or MAP sensor faults? If yes, go to troubleshooting procedure for related fault. If no, go to step 3. 3. Remove the engine fuel filter and clean in accordance with Chapter 73-10 of this manual. Reinstall the filter, run the engine in accordance with the engine and aircraft maintenance manuals. Is the fault active? If yes, replace the filter. If no, go to step 4. 4. Clear Service faults using the FST by following the steps outlined in the “Access the Field Service Tool” section in Appendix C or the latest revision of <i>SSP-118</i>. 					

Fault ID	425	Fault Group	54	Fault Name	<i>[FAULT: high fuel injector pressure delta]</i>
Fault Description	High fuel injector pressure delta fault			Fault Lamp	FFL
Root Cause	This fault indicates the fuel injector pressure delta is consistently above the maximum allowable threshold				
Troubleshooting Steps					
<ol style="list-style-type: none"> 1. Run the engine in accordance with the engine and aircraft maintenance manuals. Is the fault active? If yes, go to step 2. If no, go to step 6. 2. While engine is running, set aux fuel pump switch to on. Is fault still active? If yes, go to step 3. If no, go to step 6. 3. Are there any active or logged fuel pressure or MAP sensor faults? If yes, go to troubleshooting procedure for related fault. If no, go to step 4. 4. Inspect fuel rail, fuel pressure regulator, and fuel manifold return lines for damage or obstructions. Replace any components that are damaged or obstructed. Run the engine in accordance with the engine and aircraft maintenance manuals. Is the fault active? If yes, go to step 5. If no, go to step 6. 5. With engine running, using the FST, monitor fuel rail pressure. Is the fuel rail pressure within specified limits in accordance with Appendix A of the <i>TEO-540-A1A Engine Installation and Operation Manual</i>? If no, replace the fuel pressure regulator. If yes, contact Lycoming Engines. 6. Clear Service faults using the FST by following the steps outlined in the “Access the Field Service Tool” section in Appendix C or the latest revision of <i>SSP-118</i>. 					

Fault ID	426	Fault Group	54	Fault Name	<i>[FAULT: low fuel injector pressure delta]</i>
Fault Description	Low fuel injector pressure delta fault			Fault Lamp	FFL
Root Cause	This fault indicates the fuel injector pressure delta is consistently below the minimum allowable threshold				
Troubleshooting Steps					
<ol style="list-style-type: none"> 1. Run the engine in accordance with the engine and aircraft maintenance manuals. Is the fault active? If yes, go to step 2. If no, go to step 6. 2. While engine is running, set aux fuel pump switch to on. Is fault still active? If yes, go to step 3. If no, go to step 6. 3. Are there any active or logged fuel pressure sensor, MAP sensor, or aux fuel pump faults? If yes, go to troubleshooting procedure for related fault. If no, go to step 4. 4. Inspect airframe fuel pump, fuel filter, fuel supply lines, fuel return lines, engine fuel pump, fuel rail, fuel pressure regulator, and fuel manifold return lines for damage or obstructions. Replace any components that are damaged or obstructed. Run the engine in accordance with the engine and aircraft maintenance manuals. Is the fault active? If yes, go to step 5. If no, go to step 6. 5. With engine running, using the FST, monitor engine fuel pump and fuel rail pressure. Is fuel pump and fuel rail pressure within specified limits in accordance with Appendix A of the <i>TEO-540-A1A Engine Installation and Operation Manual</i>? If pump pressure is out of limits, replace fuel pump. If fuel rail pressure is out of limits, replace fuel pressure regulator. Then go to step 6. If both are within limits, contact Lycoming Engines. 6. Clear Service faults using the FST by following the steps outlined in the “Access the Field Service Tool” section in Appendix C or the latest revision of <i>SSP-118</i>. 					

Fault ID	427	Fault Group	54	Fault Name	<i>[FAULT: Low fuel pressure with aux pump active]</i>
Fault Description	Low fuel pressure with Aux Pump active			Fault Lamp	FFL
Root Cause	This fault indicates the fuel pump pressure is low with auxiliary pump active.				
Troubleshooting Steps					
<ol style="list-style-type: none"> 1. Run the engine in accordance with the engine and aircraft maintenance manuals. Is the fault active? If yes, go to step 2. If no, go to step 6. 2. While engine is running, set aux fuel pump switch to on. Is fault still active? If yes, go to step 3. If no, go to step 6. 3. Is there an active aux fuel pump output fault? If yes, go to corresponding troubleshooting procedure. If no, go to step 4. 4. Inspect airframe fuel pump, fuel filter, fuel supply lines for proper operation, damage or obstructions in accordance with aircraft maintenance manual. Replace any components that are not operating properly, damaged or obstructed. Run the engine in accordance with the engine and aircraft maintenance manuals. Is the fault active? If yes, go to step 5. If no, go to step 6. 5. With engine running, using the FST, monitor engine fuel pump and fuel rail pressure. Is fuel pump and fuel rail pressure within specified limits in accordance with Appendix A of the <i>TEO-540-A1A Installation and Operation Manual</i>? If pump pressure is out of limits, replace the fuel pump. If fuel rail pressure is out of limits, replace fuel pressure regulator. Then go to step 6. If both are within limits, contact Lycoming Engines. 6. Clear Service faults using the FST by following the steps outlined in the “Access the Field Service Tool” section in Appendix C or the latest revision of <i>SSP-118</i>. 					

Fault ID	428	Fault Group	54	Fault Name	<i>-Reserved-</i>
Fault Description				Fault Lamp	FFL
Root Cause					
Troubleshooting Steps					

Fault ID	429	Fault Group	54	Fault Name	<i>-Reserved-</i>
Fault Description				Fault Lamp	FFL
Root Cause					
Troubleshooting Steps					

Fault ID	430	Fault Group	54	Fault Name	<i>-Reserved-</i>
Fault Description				Fault Lamp	FFL
Root Cause					
Troubleshooting Steps					

Fault ID	431	Fault Group	54	Fault Name	<i>-Reserved-</i>
Fault Description				Fault Lamp	FFL
Root Cause					
Troubleshooting Steps					

Fault ID	432	Fault Group	55	Fault Name	<i>[FAULT: fuel filter pressure drop exceeded_2]</i>
Fault Description	Fuel filter pressure drop limit 2exceeded Fault			Fault Lamp	NTO
Root Cause	This fault indicates the fuel filter drop pressure drop has consistently exceeded its maximum allowable threshold. This also indicates a severe restricted flow between the fuel pump outlet pressure and fuel rail pressure				
Troubleshooting Steps					
<ol style="list-style-type: none"> 1. Run the engine in accordance with the engine and aircraft maintenance manuals. Is the fault active? If yes, go to step 2. If no, go to step 4. 2. Are there any active or logged fuel pressure or MAP sensor faults? If yes, go to troubleshooting procedure for related fault. If no, go to step 3. 3. Remove engine fuel filter and clean in accordance with Chapter 73-10 of this manual. Reinstall filter, run the engine in accordance with the engine and aircraft maintenance manuals. Is the fault active? If yes, replace the filter. If no, go to step 4. 4. Clear Service faults using the FST by following the steps outlined in the “Access the Field Service Tool” section in Appendix C or the latest revision of <i>SSP-118</i>. 					

Fault ID	433	Fault Group	55	Fault Name	<i>[FAULT: TLO time expired]</i>
Fault Description	TLO timer expired			Fault Lamp	NTO
Root Cause	This fault indicates the time limited operation timer has expired after a calibrated amount of time				
Troubleshooting Steps					
<ol style="list-style-type: none"> 1. Are there any active TLO faults? If yes, correct faults using troubleshooting procedure for that fault(s), then go to step 2. If no, go to step 2. 2. Contact Lycoming Engines to reset the TLO* timer. Go to step 3. 3. Set ignition switch to on, do not start engine, then Clear Service faults using the FST by following the steps outlined in the “Access the Field Service Tool” section in Appendix C or the latest revision of <i>SSP-118</i>. <p>*NOTE: It is NORMAL for the TLO time remaining discrepancy fault (Fault 329) to occur when the Primary and Secondary TLO timers are reset. These faults should clear in step 3 of this procedure.</p>					

Fault ID	434	Fault Group	55	Fault Name	<i>-Reserved-</i>
Fault Description				Fault Lamp	NTO
Root Cause					
Troubleshooting Steps					

Fault ID	435	Fault Group	55	Fault Name	<i>-Reserved-</i>
Fault Description				Fault Lamp	NTO
Root Cause					
Troubleshooting Steps					

Fault ID	436	Fault Group	55	Fault Name	<i>-Reserved-</i>
Fault Description				Fault Lamp	NTO
Root Cause					
Troubleshooting Steps					

Fault ID	437	Fault Group	55	Fault Name	<i>-Reserved-</i>
Fault Description				Fault Lamp	NTO
Root Cause					
Troubleshooting Steps					

Fault ID	438	Fault Group	55	Fault Name	<i>-Reserved-</i>
Fault Description				Fault Lamp	NTO
Root Cause					
Troubleshooting Steps					

Fault ID	439	Fault Group	55	Fault Name	<i>-Reserved-</i>
Fault Description				Fault Lamp	NTO
Root Cause					
Troubleshooting Steps					

Fault ID	440	Fault Group	56	Fault Name	<i>[FAULT: NTO lamp or Aux fuel pump output failure]</i>
Fault Description	Primary: -reserved- Secondary: NTO Lamp or Aux Pump Output Failure			Fault Lamp	None
Root Cause	This fault indicates a failure of the NTO lamp output or the Auxiliary pump output on the secondary channel				
Troubleshooting Steps					
<ol style="list-style-type: none"> 1. Is the fault active? If yes, go to step 2. If no, go to step 4. 2. Is the aux fuel pump (aircraft) controlled by the ECU? If yes, go to step 3. If no, go to NTO annunciator procedure in this section. 3. Complete the following steps to determine if the fault is generated by the NTO lamp circuit or the Aux fuel pump circuit: <ol style="list-style-type: none"> a. Turn ignition on verify the Secondary NTO annunciator flashes. If NTO annunciator flashed, go to NTO annunciator portion of this procedure. If it did not flash, go the aux fuel pump procedure in this section. 4. Clear Service faults using the FST by following the steps outlined in the “Access the Field Service Tool” section in Appendix C or the latest revision of SSP-118. <p><u>Aux Fuel Pump Procedure</u></p> <ol style="list-style-type: none"> 1. With power applied to the aircraft, monitor the aux fuel pump pressure indicator, turn the aux pump switch to ‘ON’. Did the fuel pressure increase? If no, go to step 2. If yes, go to step 3. 2. Verify power, ground connections, and control switch connections to the fuel pump using the aircraft wiring diagram manual. Are power and ground present at fuel pump when switch is in the ‘ON’ position? If yes, replace the fuel pump. If no, go to step 7. 3. Remove the aux fuel pump relay. Complete a continuity test of the harness from the relay connector to the ECU connector, aux pump switch, and relay power source, using the engine system schematic in Appendix B and airframe wiring manual. If the continuity check fails between the relay connector and the ECU, isolate to affected harness by disconnecting the airframe interface connection AF-P1. If the continuity fails between the relay connector and AF-J1, repair cable in accordance with aircraft maintenance manual. If the continuity fails between AF-P1 and ECU, contact Lycoming Engines. If the continuity fails between relay connector and switch, or relay power source, repair cable and/or replace switch in accordance with aircraft maintenance manual. If the continuity check of the wiring and switch is good and power is present at relay, replace the relay. Is fault active? If yes, replace the ECU. If no, go to next step. 4. Clear Service faults using the FST by following the steps outlined in the “Access the Field Service Tool” section in Appendix C or the latest revision of SSP-118. <p><u>NTO Annunciator Procedure</u></p> <ol style="list-style-type: none"> 1. If annunciator uses an incandescent bulb, go to step 2. If annunciator uses an LED bulb, go to step 4. 2. Replace the bulb. Does fault become inactive. If yes, go to step 3. If no, go to step 4. 3. Clear Service faults using the FST by following the steps outlined in the “Access the Field Service Tool” section in Appendix C or the latest revision of SSP-118. 4. Remove connector/wires from annunciator. Complete continuity/short circuit test on annunciator assembly, using a multi-meter and aircraft wiring manual. If annunciator is defective, replace. If annunciator passes tests, go to step 5. 5. Complete a continuity test of the harness from the annunciator to the ECU connector using the engine system schematic in Appendix B and aircraft wiring diagram manual. If the continuity check fails, isolate to affected harness by disconnecting AF-P1. If engine airframe harness is at fault, contact Lycoming Engines. If aircraft wiring is at fault, repair in accordance with aircraft maintenance manual. If the continuity checks good, replace annunciator. If fault persists, replace the ECU. 					

Fault ID	441	Fault Group	56	Fault Name	[FAULT: NTO lamp output failure]
Fault Description	Primary: NTO Lamp Output Failure Secondary: -reserved-			Fault Lamp	None
Root Cause	This fault indicates a failure of the NTO lamp output on the primary channel				
Troubleshooting Steps					
<ol style="list-style-type: none"> 1. If annunciator uses an incandescent bulb, go to step 2. If annunciator uses an LED bulb, go to step 4. 2. Replace bulb. Does fault become inactive. If yes, go to step 3. If no, go to step 4. 3. Clear Service faults using the FST by following the steps outlined in the “Access the Field Service Tool” section in Appendix C or the latest revision of <i>SSP-118</i>. 4. Remove connector/wires from annunciator. Complete continuity/short circuit test on annunciator assembly, using a multi-meter and aircraft wiring manual. If annunciator is defective, replace. If annunciator passes tests, go to step 5. 5. Complete a continuity test of the harness from the annunciator to the ECU connector using the engine system schematic in Appendix B and aircraft wiring diagram manual. If the continuity check fails, isolate to affected harness by disconnecting AF-P1. If engine airframe harness is at fault, contact Lycoming Engines. If aircraft wiring is at fault, repair in accordance with aircraft maintenance manual. If the continuity checks good, replace the annunciator. If fault persists, replace the ECU. 					
Fault ID	442	Fault Group	56	Fault Name	[FAULT: PFT lamp output failure]
Fault Description	PFT lamp output driver failure fault			Fault Lamp	None
Root Cause	This fault indicates a Pre-Flight Test lamp output failure				
Troubleshooting Steps					
<ol style="list-style-type: none"> 1. If annunciator uses an incandescent bulb, go to step 2. If annunciator uses an LED bulb, go to step 4. 2. Replace the bulb. Does fault become inactive. If yes, go to step 3. If no, go to step 4. 3. Clear Service faults using the FST by following the steps outlined in the “Access the Field Service Tool” section in Appendix C or the latest revision of <i>SSP-118</i>. 4. Remove connector/wires from annunciator. Complete continuity/short circuit test on annunciator assembly, using a multi-meter and aircraft wiring manual. If annunciator is defective, replace. If annunciator passes tests, go to step 5. 5. Complete a continuity test of the harness from the annunciator to the ECU connector using the engine system schematic in Appendix B and aircraft wiring diagram manual. If the continuity check fails, isolate to affected harness by disconnecting AF-P1. If engine airframe harness is at fault, contact Lycoming Engines. If aircraft wiring is at fault, repair in accordance with aircraft maintenance manual. If the continuity checks good, replace annunciator. If fault persists, replace the ECU. 					
Fault ID	443	Fault Group	56	Fault Name	[FAULT: FFL lamp output failure]
Fault Description	Fault Found Lamp output failure driver fault			Fault Lamp	None
Root Cause	This fault indicates a fault found lamp output failure has been consistently detected.				
Troubleshooting Steps					
<ol style="list-style-type: none"> 1. If annunciator uses an incandescent bulb, go to step 2. If annunciator uses an LED bulb, go to step 4. 2. Replace the bulb. Does fault become inactive. If yes, go to step 3. If no, go to step 4. 3. Clear Service faults using the FST by following the steps outlined in the “Access the Field Service Tool” section in Appendix C or the latest revision of <i>SSP-118</i>. 4. Remove connector/wires from annunciator. Complete continuity/short circuit test on annunciator assembly, using a multi-meter and aircraft wiring manual. If annunciator is defective, replace. If annunciator passes tests, go to step 5. 5. Complete a continuity test of the harness from the annunciator to the ECU connector using the engine system schematic in Appendix B and aircraft wiring diagram manual. If the continuity check fails, isolate to affected harness by disconnecting AF-P1. If engine airframe harness is at fault, contact Lycoming Engines. If aircraft wiring is at fault, repair in accordance with aircraft maintenance manual. If the continuity checks good, replace annunciator. If fault persists, replace the ECU. 					

Fault ID	444	Fault Group	56	Fault Name	<i>[FAULT: TOR lamp output failure]</i>
Fault Description	Take off Reserve output failure driver fault			Fault Lamp	None
Root Cause	This fault indicates Take off reserve output failure has been consistently detected.				
Troubleshooting Steps					
<ol style="list-style-type: none"> 1. If annunciator uses an incandescent bulb, go to step 2. If annunciator uses an LED bulb, go to step 4. 2. Replace the bulb. Does fault become inactive. If yes, go to step 3. If no, go to step 4. 3. Clear Service faults using the FST by following the steps outlined in the “Access the Field Service Tool” section in Appendix C or the latest revision of <i>SSP-118</i>. 4. Remove connector/wires from annunciator. Complete continuity/short circuit test on annunciator assembly, using a multi-meter and aircraft wiring manual. If annunciator is defective, replace. If annunciator passes tests, go to step 5. 5. Complete a continuity test of the harness from the annunciator to the ECU connector using the engine system schematic in Appendix B and aircraft wiring diagram manual. If the continuity check fails, isolate to affected harness by disconnecting AF-P1. If engine airframe harness is at fault, contact Lycoming Engines. If aircraft wiring is at fault, repair in accordance with aircraft maintenance manual. If the continuity checks good, replace annunciator. If fault persists, replace the ECU. 					

Fault ID	445	Fault Group	56	Fault Name	<i>-Reserved-</i>
Fault Description				Fault Lamp	None
Root Cause					
Troubleshooting Steps					

Fault ID	447	Fault Group	56	Fault Name	<i>-Reserved-</i>
Fault Description				Fault Lamp	None
Root Cause					
Troubleshooting Steps					

Fault ID	448	Fault Group	56	Fault Name	<i>-Reserved-</i>
Fault Description				Fault Lamp	None
Root Cause					
Troubleshooting Steps					

Fault ID	448	Fault Group	57	Fault Name	<i>[FAULT: cowl-flap output failure]</i>
Fault Description	Cowl Flap output failure			Fault Lamp	None
Root Cause	<p>This fault occurs to indicate inability to actuate the Cowl flap actuator as desired due to a circuit fault. The circuit fault may be internal to the ECU (drive stage) or external to the ECU (load or harness).</p> <p>The fault is set under any one of the following conditions:</p> <ul style="list-style-type: none"> - The actuator or the drive stage is Open-circuit - The actuator is short-circuited - Low Side Drive (LSD) is shorted to the GND - High Side Drive (HSD) is shorted to the GND - LSD is shorted to the V Supply - HSD is shorted to the V Supply 				
Troubleshooting Steps					
<ol style="list-style-type: none"> 1. Verify operation of the cowl flap actuator by performing the following steps: <ol style="list-style-type: none"> a. Remove connector from cowl flap actuator. b. Using a power supply (ie. Battery, DC power supply, etc.) and the aircraft wiring diagram manual, apply power and ground to the appropriate contacts on cowl flap actuator connector for the direction it needs to move. Does the cowl flap actuator operate? If yes, go to step 2. If no, replace the actuator. Then go to step 4. 2. Complete a continuity and short circuit test on the cowl flap actuator limit switch. Did tests pass? If no, replace switch. If yes, go to step 3. 3. Complete a continuity and short circuit test of the harnesses from the cowl flap actuator harness connector to the ECU connector, including limit switch wiring, using the engine system schematic in Appendix B and aircraft wiring diagram manual. If the continuity check fails, isolate to affected harness by disconnecting engine airframe harness and actuator harness. If engine airframe harness is at fault, contact Lycoming Engines. If aircraft wiring is at fault, repair in accordance with aircraft maintenance manual. If the continuity checks good, replace ECU. 4. Clear Service faults using the FST by following the steps outlined in the “Access the Field Service Tool” section in Appendix C or the latest revision of <i>SSP-118</i>. 					

Fault ID	449	Fault Group	57	Fault Name	<i>-Reserved-</i>
Fault Description				Fault Lamp	None
Root Cause					
Troubleshooting Steps					

Fault ID	450	Fault Group	57	Fault Name	<i>-Reserved-</i>
Fault Description				Fault Lamp	None
Root Cause					
Troubleshooting Steps					

Fault ID	451	Fault Group	57	Fault Name	<i>-Reserved-</i>
Fault Description				Fault Lamp	None
Root Cause					
Troubleshooting Steps					

Fault ID	452	Fault Group	57	Fault Name	<i>-Reserved-</i>
Fault Description				Fault Lamp	None
Root Cause					
Troubleshooting Steps					

Fault ID	453	Fault Group	57	Fault Name	<i>-Reserved-</i>
Fault Description				Fault Lamp	None
Root Cause					
Troubleshooting Steps					

Fault ID	454	Fault Group	57	Fault Name	<i>-Reserved-</i>
Fault Description				Fault Lamp	None
Root Cause					
Troubleshooting Steps					

Fault ID	455	Fault Group	57	Fault Name	<i>-Reserved-</i>
Fault Description				Fault Lamp	None
Root Cause					
Troubleshooting Steps					

Fault ID	456	Fault Group	58	Fault Name	<i>[FAULT: SCI transmission failure]</i>
Fault Description	SCI (Serial Communication Interface) transmission failure fault			Fault Lamp	None
Root Cause	This fault indicates a failure transmitting data via the SCI. The fault will become inactive if successful data transmission resumes on the SCI				
Fault ID	457	Fault Group	58	Fault Name	<i>[FAULT: SPI A transmission failure]</i>
Fault Description	SPI A transmission failure fault			Fault Lamp	None
Root Cause	This fault indicates a failure transmitting data via the SPI A. This fault will become inactive if successful data transmission resumes on the SPI A				
Fault ID	458	Fault Group	58	Fault Name	<i>[FAULT: SPI B transmission failure]</i>
Fault Description	SPI B transmission failure fault			Fault Lamp	None
Root Cause	This fault indicates a failure transmitting data via the SPI B. This fault will become inactive if successful data transmission resumes on the SPI B				
Fault ID	459	Fault Group	58	Fault Name	<i>[FAULT: SPI D transmission failure]</i>
Fault Description	SPI D transmission failure fault			Fault Lamp	None
Root Cause	This fault indicates a failure transmitting data via the SPI D. This fault will become inactive if successful data transmission resumes on the SPI D				
Fault ID	460	Fault Group	58	Fault Name	<i>[FAULT: INST RS232 transmission failure]</i>
Fault Description	RS232 transmission failure fault			Fault Lamp	None
Root Cause	This fault indicates a failure transmitting RS232 messages. This fault will become inactive if the transmission returns to normal				
Troubleshooting Steps for Faults 456 thru 460					
<ol style="list-style-type: none"> 1. With Ignition switch in OFF position, remove ECU power by pulling the ECU circuit breaker. Wait 10s before resetting. Is fault active? If no, go to step 3. If yes, replace the ECU. 2. Clear Service faults using the FST by following the steps outlined in the “Access the Field Service Tool” section in Appendix C or the latest revision of <i>SSP-118</i>. 					

Fault ID	461	Fault Group	58	Fault Name	<i>-Reserved-</i>
Fault Description				Fault Lamp	None
Root Cause					
Troubleshooting Steps					

Fault ID	462	Fault Group	58	Fault Name	<i>-Reserved-</i>
Fault Description				Fault Lamp	None
Root Cause					
Troubleshooting Steps					

Fault ID	463	Fault Group	58	Fault Name	<i>-Reserved-</i>
Fault Description				Fault Lamp	None
Root Cause					
Troubleshooting Steps					

Fault ID	464	Fault Group	59	Fault Name	<i>[FAULT: RTC time discrepancy]</i>
Fault Description	Real time clock time discrepancy			Fault Lamp	None
Root Cause	This fault indicates RTC time differs between the primary and secondary channels.				
Fault ID	465	Fault Group	59	Fault Name	<i>[FAULT: RTC time invalid]</i>
Fault Description	Real time clock time invalid fault			Fault Lamp	None
Root Cause	This fault indicates an invalid has been received from data logger				

Troubleshooting Steps for Faults 464 and 465					
<ol style="list-style-type: none"> 1. Is fault active or logged? If yes, go to step 2. If no, go to step 5. 2. With Ignition switch in OFF position, remove ECU power by pulling the ECU circuit breaker. Wait 10s before resetting. Is fault still active? If yes, go to step 3. If no, go to step 5. 3. Inspect the data logger and cabling for damage. If damage is noted, repair damage in accordance with the aircraft maintenance manual. If data logger is damaged, replace. If no damage noted, go to step 4. 4. Complete a continuity test of the harness from the data logger connector to the ECU connector using the engine system schematic in Appendix B and airframe wiring manual. If the continuity check fails, isolate to affected harness by disconnecting the airframe interface connection AF-P1. If the continuity fails between the data logger and AF-J1, repair cable in accordance with aircraft maintenance manual. If the continuity fails between AF-P1 and ECU, contact Lycoming Engines. If the continuity checks good, replace the data logger. 5. Clear Service faults using the FST by following the steps outlined in the “Access the Field Service Tool” section in Appendix C or the latest revision of <i>SSP-118</i>. 					

Fault ID	466	Fault Group	59	Fault Name	<i>-Reserved-</i>
Fault Description				Fault Lamp	None
Root Cause					
Troubleshooting Steps					

Fault ID	467	Fault Group	59	Fault Name	<i>-Reserved-</i>
Fault Description				Fault Lamp	None
Root Cause					
Troubleshooting Steps					

Fault ID	468	Fault Group	59	Fault Name	<i>-Reserved-</i>
Fault Description				Fault Lamp	None
Root Cause					
Troubleshooting Steps					

Fault ID	469	Fault Group	59	Fault Name	<i>-Reserved-</i>
Fault Description				Fault Lamp	None
Root Cause					
Troubleshooting Steps					

Fault ID	470	Fault Group	59	Fault Name	<i>-Reserved-</i>
Fault Description				Fault Lamp	None
Root Cause					
Troubleshooting Steps					

Fault ID	471	Fault Group	59	Fault Name	<i>-Reserved-</i>
Fault Description				Fault Lamp	None
Root Cause					
Troubleshooting Steps					

Fault ID	472	Fault Group	60	Fault Name	<i>[FAULT: data logger message watchdog]</i>
Fault Description	Data logger message watchdog fault			Fault Lamp	None
Root Cause	This fault indicates a failure transmitting messages to the data logger				
Troubleshooting Steps					
<ol style="list-style-type: none"> 1. Is fault active or logged? If yes, go to step 2. If no, go to step 5. 2. With Ignition switch in OFF position, remove ECU power by pulling the ECU circuit breaker. Wait 10s before resetting. Is fault still active? If yes, go to step 3. If no, go to step 5. 3. Inspect the data logger and cabling for damage. If damage is noted, repair damage in accordance with aircraft maintenance manual. If data logger is damage, replace. If no damage noted, go to step 4. 4. Complete a continuity test of the harness from the data logger connector to the ECU connector using the engine system schematic in Appendix B and airframe wiring manual. If the continuity check fails, isolate to affected harness by disconnecting the airframe interface connection AF-P1. If the continuity fails between the data logger and AF-J1, repair the cable in accordance with aircraft maintenance manual. If the continuity fails between AF-P1 and ECU, contact Lycoming Engines. If the continuity checks good, replace the data logger. 5. Clear Service faults using the FST by following the steps outlined in the “Access the Field Service Tool” section in Appendix C or the latest revision of <i>SSP-118</i>. 					

Fault ID	473	Fault Group	60	Fault Name	<i>[FAULT: instrumentation message watchdog]</i>
Fault Description	Instrumentation message watchdog fault			Fault Lamp	None
Root Cause	This fault indicates a failure with CAN messages on the instrumentation interface				
Troubleshooting Steps					
<ol style="list-style-type: none"> 1. With Ignition switch in OFF position, remove ECU power by pulling the ECU circuit breaker. Wait 10s before resetting. Is fault still active? If yes, go to step 2. If no, go to step 5. 2. Turn ignition switch ON. Is engine instrumentation display showing all active engine parameters correctly? If no, go to step 3. If yes, go to step 4. 3. Complete an engine instrumentation display self-test in accordance with the aircraft maintenance manual or display manufacturer’s instructions (if equipped). Did self-test pass? If yes, go to step 4. If no, replace display, then go to step 5. 4. Complete a continuity and short circuit test of the harness from the aircraft engine instrument display connector to ECU connector using the engine system schematic in Appendix B and aircraft wiring diagram. If the continuity or short circuit check fails, isolate to affected harness by disconnecting the airframe interface connection AF-P1. If problem is isolated to engine airframe harness, contact Lycoming Engines. If problem is found from aircraft engine instrument display connector to AF-J1, repair in accordance with the aircraft maintenance manual. If the continuity check is good, using aircraft maintenance manual, and serviceability of the aircraft engine instrument display has been verified, replace the ECU. 5. Clear Service faults using the FST by following the steps outlined in the “Access the Field Service Tool” section in Appendix C or the latest revision of <i>SSP-118</i>. 					

Fault ID	474	Fault Group	60	Fault Name	<i>[FAULT: transmit inter-channel message watchdog]</i>
Fault Description	Transmit inter-channel message watchdog fault			Fault Lamp	None
Root Cause	This fault indicates a failure to transmit inter-channel CAN messages				
Fault ID	475	Fault Group	60	Fault Name	<i>[FAULT: Potential Watchdog Reset]</i>
Fault Description	Potential watchdog reset fault			Fault Lamp	None
Root Cause	This fault indicates a system wide reset due to watchdog				
Troubleshooting Steps for Faults 474 and 475					
<ol style="list-style-type: none"> 1. With Ignition switch in OFF position, remove ECU power by pulling the ECU circuit breaker. Wait 10s before resetting. Is fault still active? If yes, replace ECU. If no, go to step 2. 2. Clear Service faults using the FST by following the steps outlined in the “Access the Field Service Tool” section in Appendix C or the latest revision of <i>SSP-118</i>. 					

Fault ID	476	Fault Group	60	Fault Name	<i>[FAULT: receive inter-channel message watchdog]</i>
Fault Description	Receive inter-channel message watchdog fault			Fault Lamp	None
Root Cause	This fault indicates a failure to receive inter-channel CAN messages				
Troubleshooting Steps					
<ol style="list-style-type: none"> 1. With Ignition switch in OFF position, remove ECU power by pulling the ECU circuit breaker. Wait 10s before resetting. Is fault still active? If yes, go to step 2. If no, go to step 3. 2. Are there any other active or logged CAN 2 or CAN 3 fault? If yes, go to troubleshooting procedure for corresponding fault. If no, replace the ECU. 3. Clear Service faults using the FST by following the steps outlined in the “Access the Field Service Tool” section in Appendix C or the latest revision of <i>SSP-118</i>. 					

Fault ID	477	Fault Group	60	Fault Name	<i>-Reserved-</i>
Fault Description				Fault Lamp	None
Root Cause					
Troubleshooting Steps					

Fault ID	478	Fault Group	60	Fault Name	<i>-Reserved-</i>
Fault Description				Fault Lamp	None
Root Cause					
Troubleshooting Steps					

Fault ID	479	Fault Group	60	Fault Name	<i>-Reserved-</i>
Fault Description				Fault Lamp	None
Root Cause					
Troubleshooting Steps					

Fault ID	480	Fault Group	61	Fault Name	<i>[FAULT: ArithPU]</i>
Fault Description	Arithmetic processing unit fault			Fault Lamp	None
Root Cause	This fault indicates a fault with the arithmetic processor possibly due to a memory corruption or processor failure				
Fault ID	481	Fault Group	61	Fault Name	<i>[FAULT: configurable value range check failed]</i>
Fault Description	Configurable value range check failed fault			Fault Lamp	None
Root Cause	This fault indicates one or more of the configurable values exceed their upper or lower limits				
Fault ID	482	Fault Group	61	Fault Name	<i>[FAULT: Excessive Programming Time]</i>
Fault Description	Excessive programming time fault			Fault Lamp	None
Root Cause	This fault indicates programming did not complete within the timeout limit				
Troubleshooting Steps for Faults 480 thru 482					
1. With Ignition switch in OFF position, remove ECU power by pulling the ECU circuit breaker. Wait 10s before resetting. Is fault still active? If yes, replace ECU. If no, go to step 2. 2. Clear Service faults using the FST by following the steps outlined in the “Access the Field Service Tool” section in Appendix C or the latest revision of <i>SSP-118</i> .					

Fault ID	483	Fault Group	61	Fault Name	<i>-Reserved-</i>
Fault Description				Fault Lamp	None
Root Cause					
Troubleshooting Steps					

Fault ID	484	Fault Group	61	Fault Name	<i>-Reserved-</i>
Fault Description				Fault Lamp	None
Root Cause					
Troubleshooting Steps					

Fault ID	485	Fault Group	61	Fault Name	<i>-Reserved-</i>
Fault Description	Table C-1			Fault Lamp	None
Root Cause					
Troubleshooting Steps					

Fault ID	486	Fault Group	61	Fault Name	<i>-Reserved-</i>
Fault Description				Fault Lamp	None
Root Cause					
Troubleshooting Steps					

Fault ID	487	Fault Group	61	Fault Name	<i>-Reserved-</i>
Fault Description				Fault Lamp	None
Root Cause					
Troubleshooting Steps					

Fault ID	488	Fault Group	62	Fault Name	<i>[FAULT: Lamp SPI Diag]</i>
Fault Description	SPI lamp diagnostic fault			Fault Lamp	None
Root Cause	This fault indicates a failure of the processors' SPI hardware				
Fault ID	489	Fault Group	62	Fault Name	<i>[FAULT: Lamp SPI]</i>
Fault Description	SPI lamp fault			Fault Lamp	None
Root Cause	This fault indicates a failure of the processors' SPI hardware				
Fault ID	490	Fault Group	62	Fault Name	<i>[FAULT: Consistency EMM EEPROM]</i>
Fault Description	EMM EEPROM consistency fault			Fault Lamp	None
Root Cause	This fault indicates a memory corruption affecting EEPROM				
Fault ID	491	Fault Group	62	Fault Name	<i>[FAULT: Consistency EMM FLASH]</i>
Fault Description	EMM Flash consistency fault			Fault Lamp	None
Root Cause	This fault indicates a memory corruption affecting EEPROM				

Fault ID	492	Fault Group	62	Fault Name	<i>[FAULT: Consistency ADL 1]</i>
Fault Description	ADL 1 consistency fault			Fault Lamp	None
Root Cause	Memory corruption affecting the data logger				
Fault ID	493	Fault Group	62	Fault Name	<i>[FAULT: Consistency ADL 2]</i>
Fault Description	ADL 2 consistency fault			Fault Lamp	None
Root Cause	Memory corruption affecting the data logger				
Fault ID	494	Fault Group	62	Fault Name	<i>[FAULT: Consistency CHT]</i>
Fault Description	CHT consistency fault			Fault Lamp	None
Root Cause	Memory corruption affecting CHT				
Fault ID	495	Fault Group	62	Fault Name	<i>[FAULT: Consistency TIT]</i>
Fault Description	TIT consistency fault			Fault Lamp	None
Root Cause	Memory corruption affecting TIT				
Fault ID	496	Fault Group	63	Fault Name	<i>[FAULT: Consistency AIRFLOWLOAD 1]</i>
Fault Description	Airflow load 1 consistency fault			Fault Lamp	None
Root Cause	Memory corruption affecting airflow load				
Fault ID	497	Fault Group	63	Fault Name	<i>[FAULT: Consistency AIRFLOWLOAD 2]</i>
Fault Description	Airflow load 2 consistency fault			Fault Lamp	None
Root Cause	Memory corruption affecting airflow load				
Fault ID	498	Fault Group	63	Fault Name	<i>[FAULT: Consistency CP 1]</i>
Fault Description	Configuration protocol 1 consistency fault			Fault Lamp	None
Root Cause	Memory corruption affecting CAN configuration protocol				
Fault ID	499	Fault Group	63	Fault Name	<i>[FAULT: Consistency CP 2]</i>
Fault Description	Configuration protocol 2 consistency fault			Fault Lamp	None
Root Cause	Memory corruption affecting CAN configuration protocol				
Fault ID	500	Fault Group	63	Fault Name	<i>[FAULT: Consistency PFT 1]</i>
Fault Description	PFT 1 consistency fault			Fault Lamp	None
Root Cause	Memory corruption affecting Pre-Flight Test				
Fault ID	501	Fault Group	63	Fault Name	<i>[FAULT: Consistency PFT 2]</i>
Fault Description	PFT 2 consistency fault			Fault Lamp	None
Root Cause	Memory corruption affecting Pre-Flight Test				

Fault ID	502	Fault Group	63	Fault Name	<i>[FAULT: Consistency TURBO 2]</i>
Fault Description	Turbo 2 consistency fault			Fault Lamp	None
Root Cause	Memory corruption affecting Turbo control				
Fault ID	503	Fault Group	63	Fault Name	<i>[FAULT: Consistency PROP PITCH 2]</i>
Fault Description	Prop-pitch 2 consistency fault			Fault Lamp	None
Root Cause	Memory corruption affecting prop-pitch control				
Fault ID	504	Fault Group	64	Fault Name	<i>[FAULT: Consistency TIME]</i>
Fault Description	Time consistency fault			Fault Lamp	None
Root Cause	Memory corruption affecting time keeping				
Fault ID	505	Fault Group	64	Fault Name	<i>[FAULT: Consistency NV]</i>
Fault Description	Non-Volatile consistency fault			Fault Lamp	None
Root Cause	Memory corruption affecting Non-Volatile parameter storage				
Fault ID	506	Fault Group	64	Fault Name	<i>[FAULT: Consistency NV PROCESS]</i>
Fault Description	Non-Volatile process consistency fault			Fault Lamp	None
Root Cause	Memory corruption affecting Non-Volatile parameter processing				
Fault ID	507	Fault Group	64	Fault Name	<i>[FAULT: Consistency FUEL]</i>
Fault Description	Fuel consistency fault			Fault Lamp	None
Root Cause	Memory corruption affecting Fueling				
Fault ID	508	Fault Group	64	Fault Name	<i>[FAULT: Consistency SYNC DATA]</i>
Fault Description	Sync Data consistency fault			Fault Lamp	None
Root Cause	Memory corruption affecting engine synchronization				
Fault ID	509	Fault Group	64	Fault Name	<i>[FAULT: Consistency FAULT INTERNAL PROCESS]</i>
Fault Description	Fault Internal process consistency fault			Fault Lamp	None
Root Cause	Memory corruption affecting internal faults				
Fault ID	510	Fault Group	64	Fault Name	<i>[FAULT: Consistency TFMINOR]</i>
Fault Description	Transient Fueling consistency fault			Fault Lamp	None
Root Cause	Memory corruption affecting transient fueling				
Fault ID	511	Fault Group	64	Fault Name	<i>[FAULT: Consistency TFMAJOR]</i>
Fault Description	Transient Fueling consistency fault			Fault Lamp	None
Root Cause	Memory corruption affecting transient fueling				
Fault ID	512	Fault Group	65	Fault Name	<i>[FAULT: Consistency RUN STATE]</i>
Fault Description	Run state consistency fault			Fault Lamp	None
Root Cause	Memory corruption affecting engine run state				

Fault ID	513	Fault Group	65	Fault Name	<i>[FAULT: Consistency TARGET AFR]</i>
Fault Description	Target AFR consistency fault			Fault Lamp	None
Root Cause	Memory corruption affecting air fuel ratio				
Fault ID	514	Fault Group	65	Fault Name	<i>[FAULT: Consistency IGNITION]</i>
Fault Description	Ignition consistency fault			Fault Lamp	None
Root Cause	Memory corruption affecting ignition				
Fault ID	515	Fault Group	65	Fault Name	<i>[FAULT: Consistency CYLCUT]</i>
Fault Description	Cylinder cut consistency fault			Fault Lamp	None
Root Cause	Memory corruption affecting synchronous fueling				
Fault ID	516	Fault Group	65	Fault Name	<i>[FAULT: Consistency REVLIM]</i>
Fault Description	Rev limit consistency fault			Fault Lamp	None
Root Cause	Memory corruption affecting engine speed limiting				
Fault ID	517	Fault Group	65	Fault Name	<i>[FAULT: Consistency COWL FLAP]</i>
Fault Description	Cowl Flap consistency fault			Fault Lamp	None
Root Cause	Memory corruption affecting cowl flap control				
Fault ID	518	Fault Group	65	Fault Name	<i>[FAULT: Consistency DETSENS]</i>
Fault Description	Detonation sensor consistency fault			Fault Lamp	None
Root Cause	Memory corruption affecting detonation sensors				
Fault ID	519	Fault Group	65	Fault Name	<i>[FAULT: Consistency DETCTL]</i>
Fault Description	Detonation control consistency fault			Fault Lamp	None
Root Cause	Memory corruption affecting detonation control				
Fault ID	520	Fault Group	66	Fault Name	<i>[FAULT: Consistency LAMP]</i>
Fault Description	Lamp consistency fault			Fault Lamp	None
Root Cause	Memory corruption affecting pilot indicator lamps				
Fault ID	521	Fault Group	66	Fault Name	<i>[FAULT: Consistency SFCOMMS]</i>
Fault Description	Service tool consistency fault			Fault Lamp	None
Root Cause	Memory corruption affecting service tool communications				
Fault ID	522	Fault Group	66	Fault Name	<i>[FAULT: Consistency INST]</i>
Fault Description	Instrumentation consistency fault			Fault Lamp	None
Root Cause	Memory corruption affecting instrumentation interface				
Fault ID	523	Fault Group	66	Fault Name	<i>[FAULT: Consistency FUEL FILTER 1]</i>
Fault Description	Fuel filter 1 consistency fault			Fault Lamp	None
Root Cause	Memory corruption affecting fuel filter pressure drop				

Fault ID	524	Fault Group	66	Fault Name	<i>[FAULT: Consistency FUEL FILTER 2]</i>
Fault Description	Fuel filter 2 consistency fault			Fault Lamp	None
Root Cause	Memory corruption affecting fuel filter pressure drop				
Fault ID	525	Fault Group	66	Fault Name	<i>[FAULT: Consistency GEN POWER 1]</i>
Fault Description	Gen Power 1 consistency fault			Fault Lamp	None
Root Cause	Memory corruption affecting generated power calculations				
Fault ID	526	Fault Group	66	Fault Name	<i>[FAULT: Consistency GEN POWER 2]</i>
Fault Description	Gen Power 2 consistency fault			Fault Lamp	None
Root Cause	Memory corruption affecting generated power calculations				
Fault ID	527	Fault Group	66	Fault Name	<i>[FAULT: Consistency INOPCYL 1]</i>
Fault Description	Inoperative cylinder 1 consistency fault			Fault Lamp	None
Root Cause	Memory corruption affecting inoperative cylinder detection				
Fault ID	528	Fault Group	67	Fault Name	<i>[FAULT: Consistency INOPCYL 2]</i>
Fault Description	Inoperative cylinder 2 consistency fault			Fault Lamp	None
Root Cause	Memory corruption affecting inoperative cylinder detection				
Fault ID	529	Fault Group	67	Fault Name	<i>[FAULT: Consistency ADAPT]</i>
Fault Description	Adapt fuel consistency fault			Fault Lamp	None
Root Cause	Memory corruption affecting adaptive fueling				
Fault ID	530	Fault Group	67	Fault Name	<i>[FAULT: Consistency AUX FUEL]</i>
Fault Description	Aux fuel consistency fault			Fault Lamp	None
Root Cause	Memory corruption affecting auxiliary fuel pump				
Fault ID	531	Fault Group	67	Fault Name	<i>[FAULT: Consistency ANAPROC]</i>
Fault Description	Analogue input consistency fault			Fault Lamp	None
Root Cause	Memory corruption affecting analogue input processing				
Fault ID	532	Fault Group	67	Fault Name	<i>[FAULT: Consistency DIGPROC]</i>
Fault Description	Digital input consistency fault			Fault Lamp	None
Root Cause	Memory corruption affecting digital input processing				
Fault ID	534	Fault Group	67	Fault Name	<i>[FAULT: Consistency INFER]</i>
Fault Description	Inferred values consistency fault			Fault Lamp	None
Root Cause	Memory corruption affecting inferred values				
Fault ID	535	Fault Group	67	Fault Name	<i>[FAULT: Consistency PAARB]</i>
Fault Description	Parameter arbitration consistency fault			Fault Lamp	None
Root Cause	Memory corruption affecting parameter arbitration				

Fault ID	536	Fault Group	68	Fault Name	<i>[FAULT: Consistency INTCOMTX]</i>
Fault Description	Inter-channel CAN consistency fault			Fault Lamp	None
Root Cause	Memory corruption affecting inter-channel CAN transmission				
Fault ID	537	Fault Group	68	Fault Name	<i>[FAULT: Consistency INTCOMRX]</i>
Fault Description	Inter-channel CAN consistency fault			Fault Lamp	None
Root Cause	Memory corruption affecting inter-channel CAN reception				
Fault ID	538	Fault Group	68	Fault Name	<i>[FAULT: Consistency CCP]</i>
Fault Description	CCP consistency fault			Fault Lamp	None
Root Cause	Memory corruption affecting CAN configuration protocol				
Fault ID	539	Fault Group	68	Fault Name	<i>[FAULT: Consistency MIOS 1]</i>
Fault Description	MIOS 1 consistency fault			Fault Lamp	None
Root Cause	Memory corruption affecting enhanced Modular Input output subsystem				
Fault ID	540	Fault Group	68	Fault Name	<i>[FAULT: Consistency MIOS 2]</i>
Fault Description	MIOS 2 consistency fault			Fault Lamp	None
Root Cause	Memory corruption affecting enhanced Modular Input output subsystem				
Fault ID	541	Fault Group	68	Fault Name	<i>[FAULT: Consistency FAULT_INTERNAL_MAJORFAULT]</i>
Fault Description	Internal fault consistency fault			Fault Lamp	None
Root Cause	Memory corruption affecting internal faults				
Fault ID	542	Fault Group	68	Fault Name	<i>[FAULT: Consistency GPIO]</i>
Fault Description	GPIO consistency fault			Fault Lamp	None
Root Cause	Memory corruption affecting general purpose input/output				
Fault ID	543	Fault Group	68	Fault Name	<i>[FAULT: Consistency DMA 1]</i>
Fault Description	DMA 1 consistency fault			Fault Lamp	None
Root Cause	Memory corruption affecting direct memory access controller				
Fault ID	544	Fault Group	68	Fault Name	<i>[FAULT: Consistency SPI]</i>
Fault Description	SPI consistency fault			Fault Lamp	None
Root Cause	Memory corruption affecting Serial Peripheral Interface				
Fault ID	545	Fault Group	68	Fault Name	<i>[FAULT: Consistency WATCHDOG]</i>
Fault Description	Watchdog consistency fault			Fault Lamp	None
Root Cause	Memory corruption affecting the watchdog				
Troubleshooting Steps for Faults 488 thru 545					
Replace the ECU.					

Fault ID	546	Fault Group	69	Fault Name	<i>-Reserved-</i>
Fault Description				Fault Lamp	None
Root Cause					
Troubleshooting Steps					

Fault ID	547	Fault Group	69	Fault Name	<i>-Reserved-</i>
Fault Description				Fault Lamp	None
Root Cause					
Troubleshooting Steps					

Fault ID	548	Fault Group	69	Fault Name	<i>-Reserved-</i>
Fault Description				Fault Lamp	None
Root Cause					
Troubleshooting Steps					

Fault ID	549	Fault Group	69	Fault Name	<i>[FAULT: Consistency INSTR]</i>
Fault Description	Instrumentation consistency fault			Fault Lamp	None
Root Cause	Memory corruption affecting the instrumentation interface				
Fault ID	550	Fault Group	69	Fault Name	<i>[FAULT: Consistency TPU]</i>
Fault Description	TPU consistency fault			Fault Lamp	None
Root Cause	Memory corruption affecting the instrumentation interface				
Fault ID	551	Fault Group	69	Fault Name	<i>[FAULT: Consistency LED]</i>
Fault Description	LED consistency fault			Fault Lamp	None
Root Cause	Memory corruption affecting LED				
Troubleshooting Steps for Faults 549 thru 551					
Replace the ECU.					

Fault ID	552	Fault Group	70	Fault Name	<i>[FAULT: CHT cyl 1 coss-check]</i>
Fault Description	CHT cyl 1 cross-check fault			Fault Lamp	FFL
Root Cause	This fault is a cross-check between local cylinder head temperature and inferred cylinder head temperature has consistently exceeded its calibrated maximum threshold				
Fault ID	553	Fault Group	70	Fault Name	<i>[FAULT: CHT cyl 2 coss-check]</i>
Fault Description	CHT cyl 2 cross-check fault			Fault Lamp	FFL
Root Cause	This fault indicates a cross-check between local cylinder head temperature and inferred cylinder head temperature has consistently exceeded its calibrated maximum threshold				
Fault ID	554	Fault Group	70	Fault Name	<i>[FAULT: CHT cyl 3 coss-check]</i>
Fault Description	CHT cyl 3 cross-check fault			Fault Lamp	FFL
Root Cause	This fault indicates cross-check between local cylinder head temperature and inferred cylinder head temperature has consistently exceeded its calibrated maximum threshold				
Fault ID	555	Fault Group	70	Fault Name	<i>[FAULT: CHT cyl 4 coss-check]</i>
Fault Description	CHT cyl 4 cross-check fault			Fault Lamp	FFL
Root Cause	This fault indicates the cross-check of cylinder head temperature which means a cross-check between local cylinder head temperature and inferred cylinder head temperature has consistently exceeded its calibrated maximum threshold				
Fault ID	556	Fault Group	70	Fault Name	<i>[FAULT: CHT cyl 5 coss-check]</i>
Fault Description	CHT cyl 5 cross-check fault			Fault Lamp	FFL
Root Cause	This fault indicates the cross-check of cylinder head temperature which means a cross-check between local cylinder head temperature and inferred cylinder head temperature has consistently exceeded its calibrated maximum threshold				
Fault ID	557	Fault Group	70	Fault Name	<i>[FAULT: CHT cyl 6 coss-check]</i>
Fault Description	CHT cyl 6 cross-check fault			Fault Lamp	FFL
Root Cause	This fault indicates the cross-check of cylinder head temperature which means a cross-check between local cylinder head temperature and inferred cylinder head temperature has consistently exceeded its calibrated maximum threshold				
Fault ID	558	Fault Group	70	Fault Name	<i>[FAULT: CHT cyl 7 coss-check]</i>
Fault Description	CHT cyl 7 cross-check fault			Fault Lamp	FFL
Root Cause	This fault indicates the cross-check of cylinder head temperature which means a cross-check between local cylinder head temperature and inferred cylinder head temperature has consistently exceeded its calibrated maximum threshold				
Fault ID	559	Fault Group	70	Fault Name	<i>[FAULT: CHT cyl 8 coss-check]</i>
Fault Description	CHT cyl 8 cross-check fault			Fault Lamp	FFL
Root Cause	This fault indicates the cross-check of cylinder head temperature which means a cross-check between local cylinder head temperature and inferred cylinder head temperature has consistently exceeded its calibrated maximum threshold				
Troubleshooting Steps for Faults 552 thru 559					
1. Run the engine in accordance with the engine and aircraft maintenance manuals. Is the fault active? * If yes, go to step 3. If no, go to step 2.					

Troubleshooting Steps for Faults 552 thru 559 (Cont.)

2. Using the FST, download active and service fault logs, then clear fault logs and monitor engine operation for the fault to repeat.
3. Inspect the sensor, sensor connector and lead. If any are damaged, replace the sensor per the “Sensor Replacement Procedure” in Chapter 72-70. If there is no damage, go to step 4.
4. Inspect the engine harness for visible signs of damage. If damage is found, contact Lycoming Engines. If no damage is found, go to step 5.
5. Swap the sensor from the channel giving the fault with another sensor in a different cylinder and run the engine. Did the fault move with the sensor? If yes, replace the sensor per the “Sensor Replacement Procedure” in Chapter 72-70. If no, complete a continuity test of the harness from the harness sensor connector to the ECU connector using the engine system schematic. If the continuity check fails, isolate to affected harness by disconnecting the firewall connection, then contact Lycoming Engines. If the continuity checks good, replace the ECU.

*NOTE: The steps listed above are for troubleshooting a single fault event. If there are faults on multiple thermocouples, check to see if there are any active faults for ECU ACJ offset or internal power supply. If there are any other active faults, as those just mentioned, proceed to the troubleshooting of those faults.

This page intentionally left blank.